

PERMCO

424

424 PUMPS AND MOTORS

HIGH PRESSURE SMALL DISPLACEMENT SLEEVE BUSHING PUMPS AND MOTORS

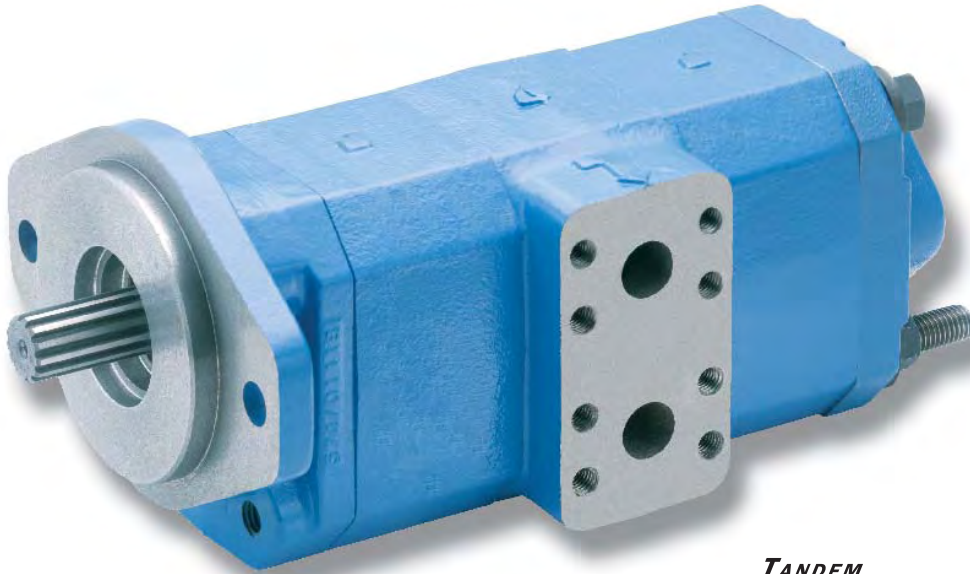

*TANDEM
SINGLE INLET/DUAL OUTLET*

FEATURES

- Heavy duty sleeve bushing design in a small frame size
- Cubic inch displacements of .62, .93 and 1.24
- Working pressure up to 4500 PSI
- Speeds up to 3000 RPM
- Flows up to 15 GPM
- Doweled and high strength cast iron construction
- 100% factory tested
- High strength alloy steel gear and shaft sets
- A wide range of porting, mounting, and shaft options available
- Pressure balanced wear plates maintain high pump efficiency throughout all operating ranges
- Both single inlet/single outlet and single inlet/dual outlet bearing carriers available



SINGLE



The Sensible Choice

Dimensional Data (inches)

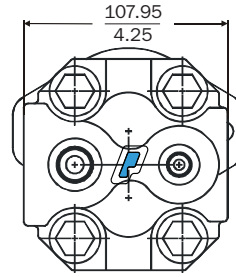
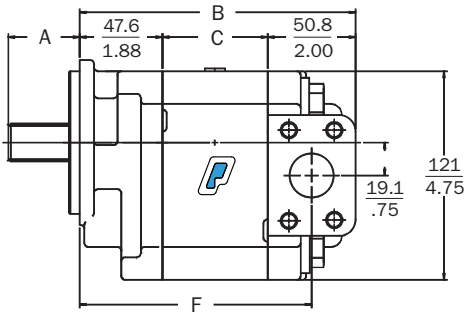

- A. 1.63" SAE "B" shaft shown, other shafts available
- B. 4.27" plus gear width
- C. 0.4" plus gear width
- D. 7.04" plus total gear width
- E. 3.58" plus front gear width
- F. 3.27" plus gear width

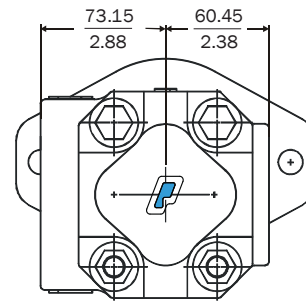
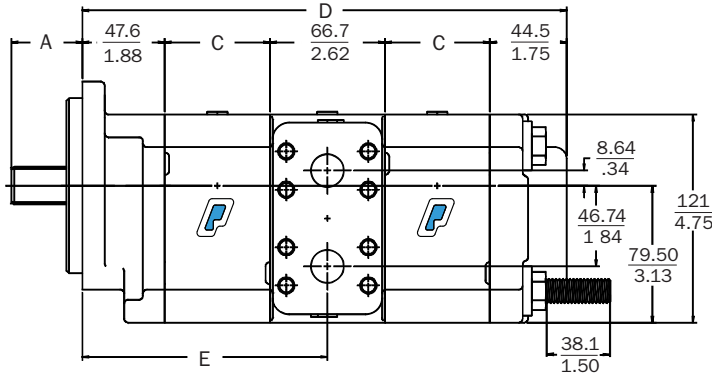

P424 Performance Chart/Specifications

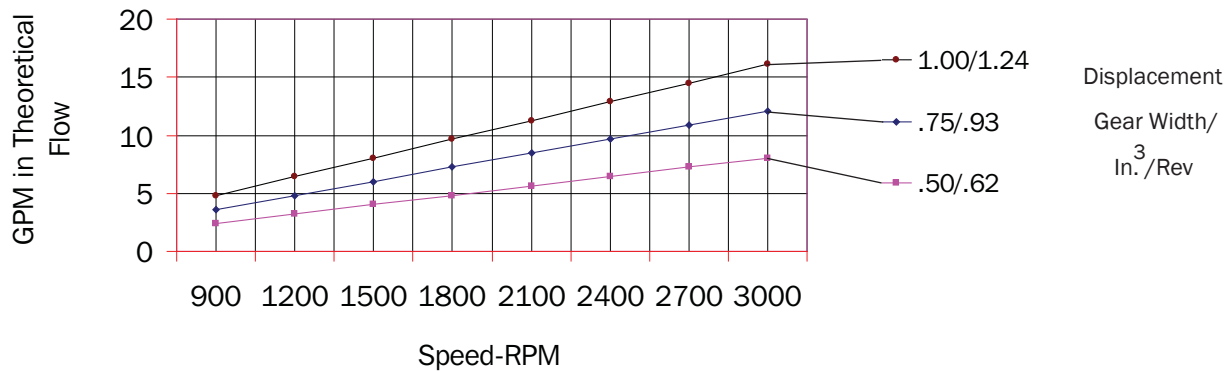

GEAR WIDTH (IN)	DISPL CU IN/CC	MAX RPM	MIN RPM	MAX PSI/BAR
.50	.62/10	3000	600	4500/310
.75	.93/15	3000	600	4500/310
1.00	1.24/20	3000	600	4500/310

Permco US
1500 Frost Road
P. O. Box 2068
Streetsboro, OH 44241

Phone 330-626-2801
Fax 330-626-2805
e-mail: info@permco.com
www.permco.com

Permco Hydraulik AG
P. O. Box 553
6343 Rotkreuz
Switzerland
e-mail: heinzm@permco.com

Permco (Tianjin) Hydraulics Inc., Ltd.
236 Jinbindadao Free Trade Zone
TianJin Port, China
e-mail: technic@permcotj.com
www.permcotj.com