

# PERMCO

# P124

## 124 SERIES PUMPS AND MOTORS

SMALL DISPLACEMENT SLEEVE BUSHING PUMPS AND MOTORS

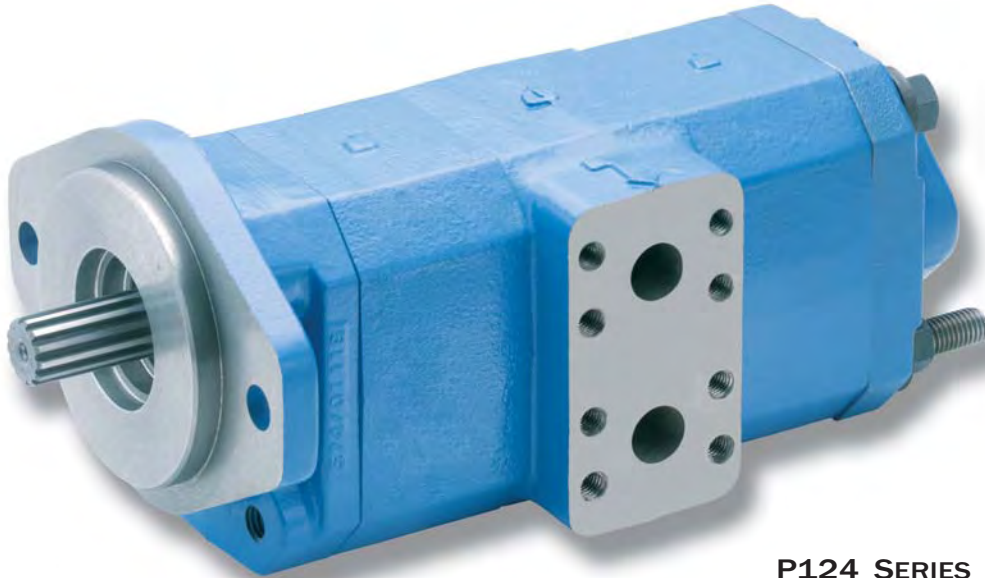

**P124 SERIES TANDEM,  
SINGLE INLET/DUAL OUTLET**

### 124 SERIES FEATURES

- ❑ Heavy duty sleeve bushing design in a small frame size
- ❑ Cubic inch displacements from 0.62 through 2.48
- ❑ Working pressure up to 3500 PSI
- ❑ Speeds up to 3000 RPM
- ❑ Flows up to 30 GPM
- ❑ Doweled and high strength cast iron construction
- ❑ 100% factory tested
- ❑ High strength alloy steel gear and shaft sets
- ❑ Available as a clutch pump
- ❑ A wide range of porting, mounting, and shaft options available
- ❑ Pressure balanced wear plates maintain high pump efficiency throughout all operating ranges
- ❑ Both single inlet/single outlet and single inlet/dual outlet bearing carriers available



**P124 SERIES SINGLE**



*The Sensible Choice*

# Dimensional Data (inches)

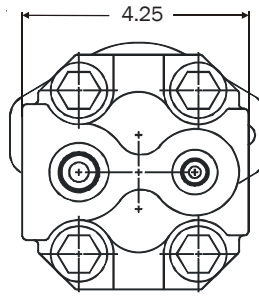
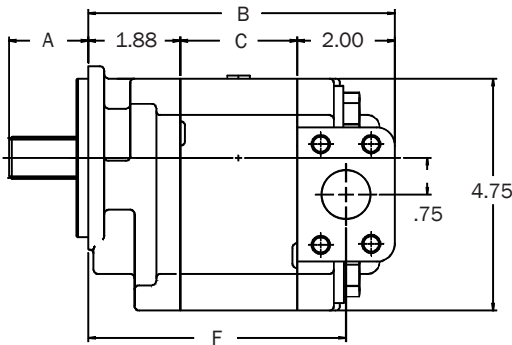

- A. 1.63" SAE "B" shaft shown, other shafts available
- B. 4.27" plus gear width
- C. 0.4" plus gear width
- D. 7.04" plus total gear width
- E. 3.58" plus front gear width
- F. 3.27" plus gear width

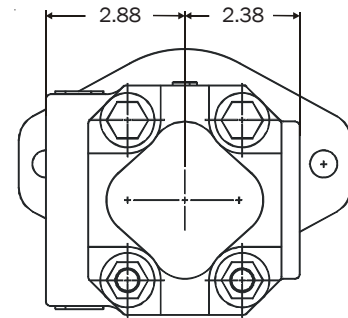
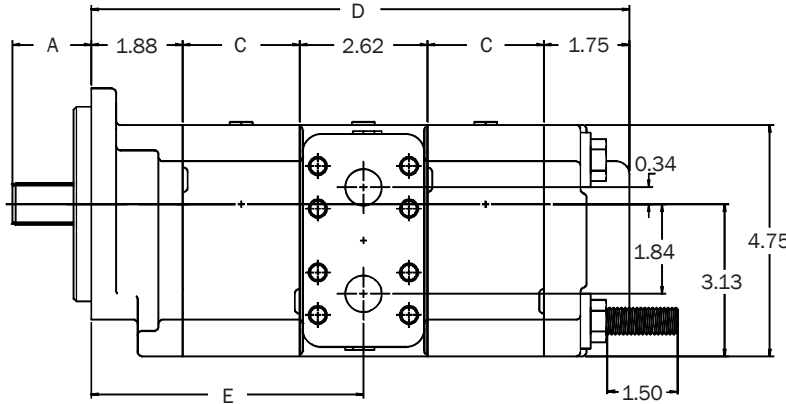

## P124 Performance Chart/Specifications

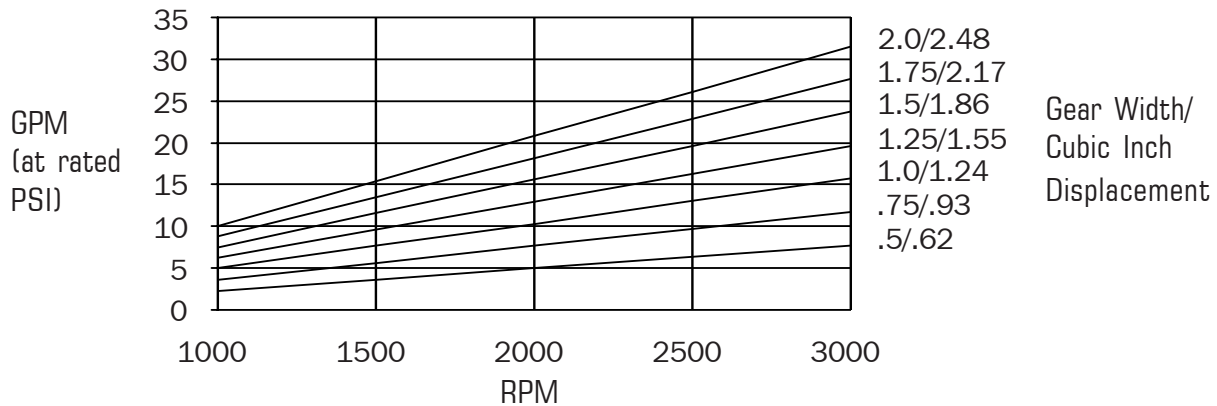

GEAR WIDTH (IN)	DISPL CU IN/CC	MAX RPM	MIN RPM	MAX PSI/BAR
.5	.62/10	3000	600	3500/241
.75	.93/15	3000	600	3500/241
1.00	1.24/20	3000	600	3500/241
1.25	1.55/25	3000	600	3500/241
1.50	1.86/30	3000	600	3300/227
1.75	2.17/35	3000	600	2900/200
2.00	2.48/40	3000	600	2500/172

Permco US  
1500 Frost Road  
P. O. Box 2068  
Streetsboro, OH 44241

Phone 330-626-2801  
Fax 330-626-2805  
e-mail info@permco.com  
www.permco.com

Permco Hydraulik AG  
P. O. Box 553  
6343 Rotkreuz  
Switzerland  
e-mail heinzm@permco.com

Permco (Tianjin) Hydraulics Inc., Ltd.  
236 Jinbindadao Free Trade Zone  
TianJin Port, China  
e-mail technic@permcotj.com  
www.permcotj.com