



EVO

Vane Product Catalog

permco.com



Permco is proud to introduce a new line of vane products; you will find our EVO vane line to be both versatile and ruggedly built for the toughest of applications. The EVO line comes in (3) series, PT6, PT7, and PT67 with design features including singles, tandems, triples, thru-drives, add-a-pump covers, motors and extremely quiet models. We know you have choices when specifying hydraulic vane products, Permco's dedication to providing the highest quality product available and consistent customer service should make the EVO line the sensible choice for your hydraulic vane applications.

EVO Product SAE Flange Chart

Type	SAE B, 2 Bolt	SAE C, 2 Bolt	SAE C, 2 & 4 Bolt	SAE C, 4 Bolt	SAE E, 4 Bolt	Disp (IN ³ /rev)	Max PSI	Max RPM	Keyed	Splined
Single	PT6C, PT6CM					6.10	4000	2800	1,2,5	3,4
Single		PT6D, PT6DM				9.64	3500	2500	1,2	3,4
Single			PT6DS, PT6DSM			9.64	3500	2500	1,2	3,4
Single		PT6E, PT6EM				16.46	3500	2200	1,2	3,4
Single	PT7BS					3.05	4640	3600	1	3,4
Single		PT7DS				9.64	4350	3000	1,2	3,4
Single				PT7DSW		9.64	3500	2500		2,X,W
Double	PT6CC,PT6CCM					6.10/6.10	4000/3062	2800/2500	1,2,R,X,V,W	3,5,T,Q
Double	PT6CCZ					6.10/6.10	4000/3062	2800/2500	X,W,V	S
Double		PT6DC,PT6DCM				9.64/6.10	3500/4000	2500/2200	1,2,5	3,4
Double			PT6DDS/PT6DDSM			9.64/9.64	3500/3062	2500/2200	1,2,5	3,4
Double		PT6EC,PT6ECM				16.46/6.10	3500/4000	2000/2200	1,2	3,4
Double		PT6ED,PT6EDM				16.46/9.64	3500/3500	2200/2200	1,2	3,4
Double					PT6EE,PT6EEM	16.46/16.46	3500/3500	2200/2200	1,2,5	3,4
Double			PT6QDC			9.64/6.10	3500/4000	2500/2500	1,2	3,4
Double	PT67CB					6.10/3.05	4000/4375	2800/2800	1,2	3,5
Double		PT67DB				9.64/3.05	3500/4375	2500/2500	1,2,5	3,4
Double		PT67EB				16.46/3.05	3500/4375	2200/2200	1,2	3,4
Triple		PT6DCC				9.64/6.10	3500/4000	2500/2500	1,2	3,4
Triple			PT6DDCS			9.64/6.10	3500/4000	2500/2500	1,2,5	3,4
Triple		PT67DCB				9.64/6.10/3.05	3500/4000/4375	2500/2500/2500	1,2	3,4
Thru-Drive	PT6CR/PT6CRM					6.10	4000	2800	1,2,5	3,4
Thru-Drive		PT6DR/PT6DRM				9.64	3500	2500	1,2,5	3
Thru-Drive		PT6ER/PT6ERM				16.46	3500	2200	1	3,4
Thru-Drive			PT6DRS/PT6DRSM			9.64	3500	2500	1,2,5	3
Thru-Drive				PT6DRSS/PT6DRSSM		9.64	3500	2500	1,2,5	3
Motor	PM4C,P4MC1					4.89		3600	1,2	3
Motor			PM4D,P4MD1			8.81		3600	1	3,5
Motor			PM4E,PM4E1			13.55		3000	1	3

EVO Product Non-SAE Flange Chart

Type	ISO 3019-2	DIN (R.17-102)	ISO 250, 4 Bolt	Max Disp (IN ³ /rev)	Max PSI	Max RPM	Keyed	Splined
Single		PT6GC		6.10	4000	2800		6
Single	PT7B			3.05	4640	3600	1	3,4
Single	PT7D			9.64	4350	3000	1,2,5	3,4
Double		PT6GCC		6.10/6.10	4000/3062	2800/2500		6
Triple			PT6EDC	16.46/9.64/6.10	3500/3500/4000	2200/2200/2200	1	

HNBR Seals (-25°- 300°F)

Permco vane pumps and motors come standard with HNBR type seals. Hydrogenated Nitrile Butadiene Rubber (HNBR), also known as Highly Saturated Nitrile (HSN), is a special class of nitrile rubber (NBR also known as Buna N) that has been hydrogenated to increase saturation of the butadiene segment of the carbon polymer backbone. Subsequent improvements to the material properties over that of Buna N include greater thermal stability, broader chemical resistance, and greater tensile strength.

NBR (BUNA N) Seals (-25°- 225°F)

Most manufacturers offer Buna-N as their standard seal arrangement; by utilizing the HNBR seal type Permco vane products provide greater temperature resistance and a wider range of fluid compatibility including petroleum based hydraulic oil, motor oil, transmission fluid, grease, water/glycol and invert emulsions, HFA, HFB and HFC fluids. HNBR seals also offer greater resistance to ozone, aging and weather resistance. Temperature range limits are also increased with HNBR type seals (-25°F to 300°F).

EPDM Seals (- 25°- 300°F)

As with most manufacturers, to accommodate for water glycol and invert emulsions fluids, seal arrangements would need to be specified as EPDM seal type; of course there is normally an extra charge for this. With Permco utilizing the HNBR seal type as our standard seal arrangement we can offer a higher quality seal along with a wider variety of fluid compatibility; all this at the same price that most manufacturers charge for Buna-N type seals. EPDM Seals are most commonly used with Aerospace fluids.

Viton Seals (-25°- 390°F)

Phosphate ester and similar type fluids still require Viton® type seals. Operating environments can also play a role in specifying the correct seal for your application; contact Support@permco.com for assistance.

Permco offers engineering and product development capabilities to assist our customers in designing products around their requirements and applications. Modifications can be made to existing units to increase performance and we have the resources to design new units and features for OEM applications.

Permco's continuous efforts to offer the highest quality products in the marketplace to its customers are not limited to the contents of this catalog. Product development is ongoing to produce a wider variety of products to accommodate customer requirements and expand offerings in the vane product line. If you have specific requirements for products not listed and/or have specific performance features not listed in this catalog, please contact Permco or your local Permco distributor for assistance.

Permco also manufactures a complete line of spur gear pumps and motors. Other catalogs contain this information.

North American, European, Africa, Australia and New Zealand customer seeking product information or location of a local Permco distributor should call our toll free number 1-800-626-2801; for Asia call our China Mainland operation at 022-25761959.



Check us out on the web: www.permco.com

The items described in this catalog are offered for sale by Permco, its subsidiaries or its authorized distributors; possession of this document does not entitle holder to purchase direct from factory. Viton® is a registered trademark of DuPont Company



Index

GENERAL	Features- Instructions	5
	General Characteristics	6
	Minimum & Maximum Speeds- Pressure Ratings- Priming at Start	7-10

Single Pump

PT6C	Ordering Code and Technical Data	11
	Dimensions and Operating Characteristics	12
PT6CM	Ordering Code and Technical Data	13
	Dimensions and Operating Characteristics	14
PT6D	Ordering Code and Technical Data	15
	Dimensions and Operating Characteristics	16
PT6DM	Ordering Code and Technical Data	17
	Dimensions and Operating Characteristics	18
PT6DS	Ordering Code and Technical Data	19
	Dimensions and Operating Characteristics	20
PT6E	Ordering Code and Technical Data	21
	Dimensions and Operating Characteristics	22
PT6EM	Ordering Code and Technical Data	23
	Dimensions and Operating Characteristics	24
PT6GC	Ordering Code and Technical Data	25
	Dimensions and Operating Characteristics	26
PT7B	Ordering Code and Technical Data	27
	Dimensions and Operating Characteristics	28
PT7D	Ordering Code and Technical Data	29
	Dimensions and Operating Characteristics	30
PT7DSW	Ordering Code and Technical Data	31
	Dimensions and Operating Characteristics	32
PT7DSWP	Ordering Code and Technical Data	33
	Dimensions and Operating Characteristics	34

Double Pump

PT6CC	Ordering Code and Technical Data	35
	Dimensions and Operating Characteristics	36
PT6CCZ	Ordering Code and Technical Data	37
	Dimensions and Operating Characteristics	38
PT6DC	Ordering Code and Technical Data	39
	Dimensions and Operating Characteristics	40
PT6DDS	Ordering Code and Technical Data	41
	Dimensions and Operating Characteristics	42
PT6EC	Ordering Code and Technical Data	43
	Dimensions and Operating Characteristics	44
PT6ED	Ordering Code and Technical Data	45
	Dimensions and Operating Characteristics	46
PT6EE	Ordering Code and Technical Data	47
	Dimensions and Operating Characteristics	48
PT6GCC	Ordering Code and Technical Data	49
	Dimensions and Operating Characteristics	50
PT6QDC	Ordering Code and Technical Data	51
	Dimensions and Operating Characteristics	52



Index

PT67CB	Ordering Code and Technical Data	53
	Dimensions and Operating Characteristics	54
PT67DB	Ordering Code and Technical Data	55
	Dimensions and Operating Characteristics	56
PT67QDCP2Z	Ordering Code and Technical Data	57
	Dimensions and Operating Characteristics	58
PT67EB	Ordering Code and Technical Data	59
	Dimensions and Operating Characteristics	60

Triple Pump

PT6DCC	Ordering Code and Technical Data	61
	Dimensions and Operating Characteristics	62
PT6DDCS	Ordering Code and Technical Data	63
	Dimensions and Operating Characteristics	64
PT6EDC	Ordering Code and Technical Data	65
	Dimensions and Operating Characteristics	66
PT67DCB	Ordering Code and Technical Data	67
	Dimensions and Operating Characteristics	68

Thru-Drive Pump

PT6CR	Ordering Code and Technical Data	69
	Dimensions and Operating Characteristics	70
PT6DR	Ordering Code and Technical Data	71
	Dimensions and Operating Characteristics	72
PT6ER	Ordering Code and Technical Data	73
	Dimensions and Operating Characteristics	74
PT6DRS	Ordering Code and Technical Data	75
	Dimensions and Operating Characteristics	76
PT6DRSS	Ordering Code and Technical Data	77
	Dimensions and Operating Characteristics	78
PT6 * R	Adapter and Coupling Selection	79
PT6, 7 SERIES	Porting Diagrams	80 -81

Vane Motor

	Maximum Speed, Pressure Ratings PM4* Series	82-94
PM4C	Ordering Code and Technical Data	95
	Dimensions and Operating Characteristics	96
PM4D	Ordering Code and Technical Data	97
	Dimensions and Operating Characteristics	98
PM4E	Ordering Code and Technical Data	99
	Dimensions and Operating Characteristics	100

Reference

	Hydraulic Fluids and Shafts	101
	Pump Selection & Pressure Rating Description	102
	Description for Industrial and Mobile	103
	Viscosity Conversion & Torque Specifications	104



FEATURES: PT6/PT7 SERIES INDUSTRIAL AND MOBILE APPLICATION

PT6 SERIES VERSATILE APPLICATIONS

Permco Vane Pumps are used throughout the industry in many mobile and industrial applications, and are suitable for use with mineral oils as well as fire resistant fluids.

CARE IN APPLICATIONS

1. Check speed range, pressure, temperature, pump rotation, fluid quality and viscosity.
2. Check pump inlet conditions according to application requirements
3. Shaft type should support operating torque.
4. Choose the correct coupling to minimize pump shaft load (weight, and misalignment).
5. Proper filtration must be adequate for the lowest contamination level.
6. Environment of pump (noise reflection, shock, and pollution).

LARGER FLOW

Greater flow for the envelope size is achieved by increased displacement cam rings; at high permissible speeds with atmospheric inlet

B→ 1.8 to 16 GPM @ 1200 RPM, 0.35 to 3.05 in³/rev (5.7 to 50 cm³/rev). 4650 PSI Max (320 Bar)

C→ 6 to 31 GPM @ 1200 RPM, 1.28 to 6.10 in³/rev (21 to 100 cm³/rev). 4000 PSI Max (275 Bar)

D→ 20 to 50 GPM @ 1200 RPM, 4.03 to 9.64 in³/rev (66 to 158 cm³/rev). 4060 PSI Max (280 Bar)

E→ 42 to 85 GPM @ 1200 RPM, 8.06 to 16.42 in³/rev (132 to 269 cm³/rev). 3500 PSI Max (240 Bar)

HIGHER PRESSURE

Pressure ratings to 4650 PSI (320 Bar) reduce size and cost of actuators, valves and lines, and give extended life at reduced pressures.

EXCELLENT EFFICIENCY

Better efficiency under load increases productivity, reducing heating and operating costs.

FLEXIBLE MOUNTING

Up to 32 positions for double pumps and up to 128 for triple pumps: this reduces mounting costs and improves performance.

LOW NOISE

For increased operator safety and acceptance. Meets or exceeds many mobile and industrial specifications.

CONFORMITY

SAE-J744c 2-bolt standards to ISO 3019-1 in various keyed and splined shaft options offered.

ADVANCED CARTRIDGE DESIGN

Designed for simple drop-in assemblies. This allows easy conversion or renewal of serviceable elements in minutes at minimum expense and risk of contamination. Pump rotation (mobile design) is easy to change by changing the position of the cam ring on port plate dowel pin hole.

WIDE VISCOSITY RANGE

Viscosities for mobile design from 9240 to 60 SUS (860 to 10cSt) permit colder starts and hotter running. The balanced design compensates for wear and temperature changes. At high viscosity or cold temperature the rotor to side plates gap is well lubricated and improves mechanical efficiency.

SYNTHETICS

Including phosphate esters, chlorinated hydrocarbons, water glycols and invert emulsions may be pumped at higher pressures and with longer service life by these pumps.



GENERAL CHARACTERISTICS

Series	Mounting Standard (SAE J477c ISO/3019-1)	Displacement (in ³ /rev)	Displacement (cm ³ /rev)	Speed		Max. Pressure		Weight (without connectors and bracket)		SAE 4-bolt J518-ISO/DIS 6162-1			
				max	min	PSI	Bar	lbs	Kg	suction	pressure		
PT6C/ PT6CM	SAE - B	0.66 - 6.10	10.8 - 100.0	2800	600 600	4000	275	34.0	15.5	1 1/2"	1"		
PT6D/ PT6DM	SAE - C	2.81 - 9.64	47.6 - 190.5	2500	600 600	3500	240	60.9	27.62	2"	1 1/4"		
PT6E/ PT6EM	SAE - C	8.07 - 16.46	132.3 - 269.8	2200	600 600	3500	240	95.1	43.14	3"	1 1/2"		
PT6GC	R.17-102	0.66 - 6.10	10.8 - 100.0	2800	600	4000	275	39.7	18.0	1 1/2"	1" SAE		
PT7B	ISO 3019-2 100 A2 HW	0.35 - 3.05	5.7 - 50.0	3600	600	4640	320	55.4	25.12	1 1/2"	1" or 3/4"		
PT7BS	SAE B SAE J744												
PT7D	ISO 3019-2 125 A2 HW	2.68 - 9.64	43.9 - 158.0	3000	600	4350	300	57.3	26.1	2"	1" 1/4"		
PT7DS	SAE C SAE J744												
PT6CR	SAE - B	0.66 - 6.10	10.8 - 100.0	2800	600 600	4000	275	44.5	20.2	1 1/2"	1"		
PT6DR	SAE - C	2.81 - 9.64	47.6 - 190.5	2500	600 600	3500	240	73.2	33.2	2"	1 1/4"		
PT6ER	SAE - C	8.07 - 16.46	132.3 - 269.8	2200	600 600	3500	240	107.1	48.6	3"	1 1/2"		
											P1	P2	
PT6CC/ PT6CCM	SAE - B	P1= 0.66 - 6.10 P2= 0.66 - 6.10	P1=10.8 - 100.0 P2=10.8 - 100.0	2800	600 600	4000	275	58.4	26.5	2 1/2" or 3"	1"	1" or 3/4"	
PT6GCC	R.17-102	P1= 0.66 - 6.10 P2= 0.66 - 6.10	P1=10.8 - 100.0 P2=10.8 - 100.0	2800	600	4000	275	63.5	28.8	2 1/2" or 3"	1"	1" or 3/4"	
PT6DC/ PT6DCM	SAE - C	P1= 2.81 - 9.64 P2= 0.66 - 6.10	P1=47.6 - 190.5 P2=10.8 - 100.0	2500	600 600	3500 4000	240 275	84.9	38.5	3"	1 1/4"	1" or 3/4"	
PT6DDS	SAE - C	P1= 2.81 - 9.64 P2= 2.81 - 9.64	P1=47.6 - 190.5 P2=47.6 - 190.5	2500	600	3500	240	123.4	56.0	4"	1 1/4"	1 1/4"	
PT6EC/ PT6ECM	SAE - C	P1= 8.07 - 16.46 P2= 0.66 - 6.10	P1=132.3 - 269.8 P2=10.8 - 100.0	2200	600 600	3500 4000	240 275	120.4	54.6	3 1/2"	1 1/2"	1"	
PT6ED/ PT6EDM	SAE - C	P1= 8.07 - 16.46 P2= 2.81 - 9.64	P1=132.3 - 269.8 P2=47.6 - 190.5	2200	600 600	3500 3500	240 240	140.0	63.5	4"	1 1/2"	1 1/4"	
PT6EE	ISO-3019-2 250 B4 HW	P1= 8.07 - 16.46 P2= 8.07 - 16.46	P1=132.3 - 269.8 P2=132.3 - 269.8	2200	600	3500	240	209.4	95.0	4"	1 1/2"	1 1/4"	
PT6EES	SAE - E												
PT67CB	SAE B SAE J744	P1= 0.66 - 6.10 P2= 0.35 - 3.05	P1=10.8 - 100.0 P2=5.7 - 50.0	2800	600	4350	300	59.3	26.9	2 1/2"	1"	3/4"	
PT67DB	SAE C SAE J744	P1= 2.81 - 9.64 P2= 0.35 - 3.05	P1=47.6 - 190.5 P2=5.7 - 50.0	2500	600	4350	300	80.5	36.6	3"	1 1/4"	3/4"	
PT67EB	SAE C SAE J744	P1= 8.07 - 16.46 P2= 0.35 - 3.05	P1=132.2 - 269.8 P2=5.7 - 50.0	2200	600	4350	300	122.1	55.0	3 1/2"	1 1/2"	3/4"	
											P1	P2	P3
PT6DCC	SAE - C	P1= 2.81 - 9.64 P2= 0.66 - 6.10 P3= 0.66 - 6.10	P1=47.6 - 190.5 P2=10.8 - 100.0 P3=10.8 - 100.0	2500	600 600	3500 4000	240 275	143.3	65.0	4"	1 1/4"	1"	1" or 3/4"
PT6DDCS	SAE - C	P1= 2.81 - 9.64 P2= 2.81 - 9.64 P3= 0.66 - 6.10	P1=47.6 - 190.5 P2=47.6 - 190.5 P3=10.8 - 100.0	2500	600 600	3500 4000	240 275	145.2	66.0	4"	1 1/4"	1 1/4"	1" or 3/4"
PT6EDC	ISO 3019-2 250 B4 HW	P1= 8.07 - 16.46 P2= 2.81 - 9.64 P3= 0.66 - 6.10	P1=132.3 - 269.8 P2=47.6 - 190.5 P3=10.8 - 100.0	2200	600 600	3500 3500 3500	240 240 275	245.8	111.5	4"	1 1/2"	1 1/4"	1" or 3/4"
PT67DCB	SAE C SAE J744	P1= 2.81 - 9.64 P2= 0.66 - 6.10 P3= 0.35 - 3.05	P1=47.6 - 190.5 P2=10.8 - 100.0 P3=5.7 - 50.0	2500	600	4350	300	143.3	65.0	4"	1 1/4"	1"	3/4"



MINIMUM AND MAXIMUM SPEED, PRESSURE RATINGS PT6/PT7 SERIES INDUSTRIAL AND MOBILE APPLICATION

Model of Pump	Disp. (Series)	Theoretical Displacement Vi		Minimum Speed	Maximum Speed		Maximum Pressure																		
					HF-0, HF-1 HF-2	HF-3, HF-4 HF-5	HF-0, HF-2				HF-1, HF-4 HF-5				HF-3										
					RPM	RPM	Int.	Int.	Cont.	Cont.	Int.	Int.	Cont.	Cont.	Int.	Int.	Cont.	Cont.							
in ³ /rev	cm ³ /rev	RPM	RPM	RPM	PSI	Bar	PSI	Bar	PSI	Bar	PSI	Bar	PSI	Bar	PSI	Bar									
PT6C PT6CM PT6CP PT6CG	003	0.66	10.8	600	2800	1800	4000	276	3500	241	3000	207	2500	172	2500	172	2000	138							
	004	0.85	13.9																						
	005	1.05	17.2																						
	006	1.30	21.3																						
	008	1.61	26.4																						
	010	2.08	34.1																						
	012	2.26	37.0																						
	014	2.81	46.0																						
	017	3.56	58.3																						
	020	3.89	63.7																						
	022	4.29	70.3																						
	025	4.84	79.3																						
	028	5.42	88.8		2500	3000	210	2300	160	2300	160														
031	6.10	100.0																							
PT6D PT6DM PT6DP PT6DS	014	2.81	46.0	600	2500	1800	3500	241	3000	207	3000	207	2500	172	2500	172	2500	172							
	017	3.55	58.2																						
	020	4.03	66.0																						
	024	4.85	79.5																						
	028	5.47	89.6																						
	031	6.00	98.3																						
	035	6.77	110.9																						
	038	7.34	120.3																						
	042	8.30	136.0																2200	3000	207	2300	160	2300	160
	045	8.85	145.0																						
050	9.64	158.0																							
PT6E PT6EM PT6EP PT67E	042	8.07	132.2	600	2200	1800	3500	241	3000	207	3000	207	2500	172	2500	172	2000	138							
	045	8.69	142.4																						
	050	9.67	158.5																						
	052	10.06	164.9																						
	054	10.44	171.0																						
	057	11.19	183.4																						
	062	12.00	196.6																						
	066	13.02	213.4																						
	072	13.86	227.1																3000	207	2500	172	2500	172	2300
085	16.46	269.7																							
PT7(B) PT7(B)S	B02	0.35	5.7	600	3600	1800	4650 ¹	320 ¹	4200	290	3500	241	3000	207	2500	172	2000	138							
	B03	0.60	9.8																						
	B04	0.78	12.8																						
	B05	0.97	15.9																						
	B06	1.20	19.7																						
	B07	1.37	22.5																						
	B08	1.51	24.7																						
	B09	1.70	27.9																						
	B10	1.92	31.5																						
	B11	2.14	35.1																3000	4350	300	4000	276		
	B12	2.47	40.5																						
	B14	2.70	44.2																						
	B15	3.01	49.3																						
PT7(D) PT7(D)S	B14	2.69	44.0	600	3600	1800	4350 ¹	320 ¹	4200	290	3500	241	3000	207	2500	172	2000	138							
	B17	3.36	55.0																						
	B20	4.03	66.0																						
	B22	4.27	70.0																						
	B24	4.95	81.1																						
	B28	5.49	90.0																						
	B31	6.05	99.2																						
	B35	6.92	113.4																						
	B38	7.36	120.6																						
	B42	8.39	137.5																3000	300	4000	276			
	045 ²	8.89	145.7																						
	050 ²	9.64	158.0																						

Performance data shown throughout this catalog is a result of a series of laboratory tests and is not representative of any one unit



MINIMUM AND MAXIMUM SPEED, PRESSURE RATINGS PT6/PT7 SERIES INDUSTRIAL AND MOBILE APPLICATION

Model of Pump	Disp. (Series)	Theoretical Displacement Vi		Minimum Speed	Maximum Speed			Maximum Pressure										
					HF-0, HF-1 HF-2	HF-3, HF-4 HF-5	HF-0, HF-2				HF-1, HF-4 HF-5				HF-3			
					RPM	RPM	Int.	Int.	Cont.	Cont.	Int.	Int.	Cont.	Cont.	Int.	Int.	Cont.	Cont.
in ³ /rev	cm ³ /rev	RPM	RPM	RPM	PSI	Bar	PSI	Bar	PSI	Bar	PSI	Bar	PSI	Bar	PSI	Bar		
PT7(BB)/S PT67C(B) PT7D(B)/S PT7E(B)/S PT67D(BB) PT67DC(B) PT7DD(B)/S PT7ED(B)/S	B02	0.35	5.7	600	2200 ³	1800	T7BB T7BBS 4650 ¹	320	T7BB T7BBS 4200	290	3500	241	3000	207	2500	172	2000	138
	B03	0.60	9.8															
	B04	0.78	12.8															
	B05	0.97	15.9															
	B06	1.20	19.7															
	B07	1.37	22.5															
	B08	1.51	24.7															
	B09	1.70	27.9															
	B10	1.92	31.5															
	B11	2.14	35.1															
	B12	2.47	40.5															
	B14	2.70	44.2															
	B15	3.01	49.3				4060	280	3500	241								
PT6(CC) PT67(CB) PT67D(C) PT67E(C) PT67D(C)B PT67D(CC) PT67DD(C)S PT67ED(C)/S	003	0.66	10.8	600	2200 ³	1800	4000	276	3500	241	3000	207	2500	172	2500	172	2000	138
	005	1.05	17.2															
	006	1.30	21.3															
	008	1.61	26.4															
	010	2.08	34.1															
	012	2.26	37.0															
	014	2.81	46.0															
	017	3.56	58.3															
	020	3.89	63.7															
	022	4.29	70.3															
	025	4.84	79.3															
	028	5.42	88.8															
	031	6.10	100.0				3000	207	2300	160			2300	160				
PT6(D)C PT6(DD)S PT67(D)B PT7(D)B/S PT67(D)C PT7(DD)/S PT67(D)BB PT7E(D)S PT67(D)CB PT67(D)CC B38 PT7(DD)B/S PT67(DD)CS PT7E(D)B/S PT67E(D)C/S	B14	2.64	43.3	600	2200 ³	1800	3630	250	3000	207	3500	241	3000	207	2500	172	2000	138
	B17	3.30	54.1															
	B20	3.95	64.7															
	B22	4.29	70.3															
	B24	4.86	79.6															
	B28	5.39	88.3															
	B31	5.94	97.3															
	B35	6.80	111.4															
	B38	7.23	118.5															
	B42	8.26	135.4															
	045 ²	8.89	145.7															
	050 ²	9.64	158.0															
							3000	207	2300	160	3000	207	2500	172				
PT7(E)B/S PT67(E)C PT7(E)DS PT7(E)E/S PT67(E)DB/S PT67(E)DC/S	042	8.07	132.2	600	2200 ³	1800	3500	241	3000	207	3000	207	2500	172	2500	172	2000	138
	045	8.70	142.6															
	050	9.67	158.5															
	052	10.00	163.9															
	054	10.43	170.9															
	057	11.18	183.2															
	062	12.00	196.6															
	066	13.00	213.0															
	072	13.86	227.1															
	085	16.40	268.7				1300	90	1100	76	1100	76	1100	76	1100	76	1100	76

HF-0, HF-2 = Anti-wear petroleum base
 HF-1 = Non anti-wear petroleum base
 HF-3 = Water-in-oil invert emulsions
 HF-4 = Water glycol solutions
 HF-5 = Synthetic fluids

- 1) Please contact Permco for applications over 4350 PSI (300 Bar)
- 2) Ten vane technology
- 3) Please consult Permco with higher speeds

For further information or if performance characteristics outlined above do not meet your own particular application requirements, please consult Permco factory or your local Permco distributor.

ATTENTION AT START-UP

- * At first start of operation pump shaft should be at the lowest speed and the lowest pressure to obtain priming. If a pressure relief valve is used at the outlet it should be backed off to zero pressure and/or to the lowest pressure setting.
- * When possible an air bleed off should be provided in the circuit to facilitate purging of system air.
- * Never operate the pump shaft at top speed and pressure without checking for completion of pump priming, and the fluid has no aeration.

Performance data shown throughout this catalog is a result of a series of laboratory tests and is not representative of any one unit



MINIMUM ALLOWABLE INLET PRESSURE [PSI (BAR) ABSOLUTE] PT6/PT7 SERIES INDUSTRIAL APPLICATIONS

Cartridges		Speed (RPM)										
Sizes	Disp	1200	1500	1800	2100	2200	2300	2500	2800	3000	3600	
B	B02	11.6 (.80)	11.6 (.80)	11.6 (.80)	11.6 (.80)	11.6 (.80)	11.6 (.80)	11.6 (.80)	11.6 (.80)	11.6 (.80)	11.6 (.80)	
	B03	11.6 (.80)	11.6 (.80)	11.6 (.80)	11.6 (.80)	11.6 (.80)	11.6 (.80)	11.6 (.80)	11.6 (.80)	11.6 (.80)	11.6 (.80)	
	B04	11.6 (.80)	11.6 (.80)	11.6 (.80)	11.6 (.80)	11.6 (.80)	11.6 (.80)	11.6 (.80)	11.6 (.80)	11.6 (.80)	11.6 (.80)	
	B05	11.6 (.80)	11.6 (.80)	11.6 (.80)	11.6 (.80)	11.6 (.80)	11.6 (.80)	11.6 (.80)	11.6 (.80)	11.6 (.80)	11.6 (.80)	
	B06	11.6 (.80)	11.6 (.80)	11.6 (.80)	11.6 (.80)	11.6 (.80)	11.6 (.80)	11.6 (.80)	11.6 (.80)	11.9 (.82)	14.2 (.98)	
	B07	11.6 (.80)	11.6 (.80)	11.6 (.80)	11.6 (.80)	11.6 (.80)	11.6 (.80)	11.6 (.80)	11.6 (.80)	11.9 (.82)	14.2 (.98)	
	B08	11.6 (.80)	11.6 (.80)	11.6 (.80)	11.6 (.80)	11.6 (.80)	11.6 (.80)	11.6 (.80)	11.6 (.80)	12.3 (.85)	15.2 (1.05)	
	B09	11.6 (.80)	11.6 (.80)	11.6 (.80)	11.6 (.80)	11.6 (.80)	11.6 (.80)	11.6 (.80)	11.6 (.80)	12.3 (.85)	15.2 (1.05)	
	B10	11.6 (.80)	11.6 (.80)	11.6 (.80)	11.6 (.80)	11.6 (.80)	11.6 (.80)	11.6 (.80)	11.6 (.80)	13.1 (.90)	16.7 (1.15)	
	B11	11.6 (.80)	11.6 (.80)	11.6 (.80)	11.6 (.80)	11.6 (.80)	11.6 (.80)	11.6 (.80)	11.6 (.80)	13.1 (.90)		
	B12	11.6 (.80)	11.6 (.80)	11.6 (.80)	11.6 (.80)	11.6 (.80)	11.6 (.80)	11.6 (.80)	11.6 (.80)	13.1 (.90)		
	B14	11.6 (.80)	11.6 (.80)	11.6 (.80)	11.6 (.80)	11.6 (.80)	11.6 (.80)	12.2 (.84)	14.4 (.99)	16.4 (1.13)		
	B15	11.6 (.80)	11.6 (.80)	11.6 (.80)	11.6 (.80)	11.6 (.80)	11.6 (.80)	12.2 (.84)	14.4 (.99)	16.4 (1.13)		
	C	003	11.6 (.80)	11.6 (.80)	11.6 (.80)	11.6 (.80)	11.6 (.80)	11.6 (.80)	13.1 (.90)	14.5 (1.0)		
		005	11.6 (.80)	11.6 (.80)	11.6 (.80)	11.6 (.80)	11.6 (.80)	11.6 (.80)	13.1 (.90)	14.5 (1.0)		
006		11.6 (.80)	11.6 (.80)	11.6 (.80)	11.6 (.80)	11.6 (.80)	11.6 (.80)	13.1 (.90)	14.5 (1.0)			
008		11.6 (.80)	11.6 (.80)	11.6 (.80)	11.6 (.80)	11.6 (.80)	11.6 (.80)	13.1 (.90)	14.5 (1.0)			
010		11.6 (.80)	11.6 (.80)	11.6 (.80)	11.6 (.80)	11.6 (.80)	11.6 (.80)	13.1 (.90)	14.5 (1.0)			
012		11.6 (.80)	11.6 (.80)	11.6 (.80)	11.6 (.80)	11.6 (.80)	12.3 (.85)	13.3 (.92)	14.5 (1.0)			
014		11.6 (.80)	11.6 (.80)	11.6 (.80)	11.6 (.80)	11.6 (.80)	12.3 (.85)	13.8 (.95)	14.5 (1.0)			
017		11.6 (.80)	11.6 (.80)	11.6 (.80)	11.6 (.80)	12.3 (.85)	13.1 (.90)	13.8 (.95)	14.9 (1.03)			
020		11.6 (.80)	11.6 (.80)	11.6 (.80)	11.6 (.80)	12.3 (.85)	13.1 (.90)	13.8 (.95)	14.9 (1.03)			
022		11.6 (.80)	11.6 (.80)	11.6 (.80)	12.3 (.85)	13.1 (.90)	13.1 (.90)	14.2 (.98)	15.2 (1.05)			
025		11.6 (.80)	11.6 (.80)	11.6 (.80)	13.1 (.90)	13.8 (.95)	13.8 (.95)	15.2 (1.05)				
028		11.6 (.80)	11.6 (.80)	11.6 (.80)	13.1 (.90)	14.2 (.98)	14.2 (.98)	15.7 (1.08)				
031		11.6 (.80)	11.6 (.80)	11.6 (.80)	12.3 (.85)	13.1 (.90)	16.1 (1.11)	16.1 (1.11)				
D		B14	11.6 (.80)	11.6 (.80)	11.6 (.80)	11.6 (.80)	11.6 (.80)	11.6 (.80)	11.6 (.80)	11.6 (.80)	11.6 (.80)	
	B17	11.6 (.80)	11.6 (.80)	11.6 (.80)	11.6 (.80)	11.6 (.80)	11.6 (.80)	11.6 (.80)	11.6 (.80)	11.6 (.80)		
	B20	11.6 (.80)	11.6 (.80)	11.6 (.80)	11.6 (.80)	11.6 (.80)	11.6 (.80)	11.6 (.80)	11.9 (.82)	12.5 (.86)		
	B22	11.6 (.80)	11.6 (.80)	11.6 (.80)	11.6 (.80)	11.6 (.80)	11.6 (.80)	11.6 (.80)	12.0 (.83)	12.8 (.88)		
	B24	11.6 (.80)	11.6 (.80)	11.6 (.80)	11.6 (.80)	11.6 (.80)	11.6 (.80)	11.6 (.80)	12.5 (.86)	13.8 (.95)		
	B28	11.6 (.80)	11.6 (.80)	11.6 (.80)	11.6 (.80)	11.6 (.80)	11.6 (.80)	11.6 (.80)	12.8 (.88)	14.5 (1.0)		
	B31	11.6 (.80)	11.6 (.80)	11.6 (.80)	11.6 (.80)	11.6 (.80)	11.6 (.80)	11.6 (.80)	13.1 (.90)	15.2 (1.05)		
	B35	11.6 (.80)	11.6 (.80)	11.6 (.80)	11.6 (.80)	11.6 (.80)	11.6 (.80)	12.2 (.84)	14.1 (.97)			
	B38	11.6 (.80)	11.6 (.80)	11.6 (.80)	11.6 (.80)	11.6 (.80)	11.6 (.80)	12.5 (.86)	14.7 (1.01)			
	B42	11.6 (.80)	11.6 (.80)	11.6 (.80)	11.6 (.80)	11.6 (.80)	11.6 (.80)	13.1 (.90)				
	045	11.6 (.80)	11.6 (.80)	12.3 (.85)	14.2 (.98)	15.2 (1.05)						
050	11.6 (.80)	11.6 (.80)	12.3 (.85)	14.8 (1.02)	15.8 (1.09)							
E	042	11.6 (.80)	11.6 (.80)	11.6 (.80)	13.1 (.90)	14.5 (1.0)						
	045	11.6 (.80)	11.6 (.80)	11.6 (.80)	13.1 (.90)	14.5 (1.0)						
	050	11.6 (.80)	11.6 (.80)	11.6 (.80)	13.1 (.90)	14.5 (1.0)						
	052	11.6 (.80)	11.6 (.80)	11.6 (.80)	13.1 (.90)	14.5 (1.0)						
	054	11.6 (.80)	11.6 (.80)	11.6 (.80)	13.1 (.90)	14.5 (1.0)						
	057	11.6 (.80)	11.6 (.80)	12.3 (.85)	13.8 (.95)	14.5 (1.0)						
	062	11.6 (.80)	11.6 (.80)	12.3 (.85)	13.8 (.95)	14.5 (1.0)						
	066	12.3 (.85)	12.3 (.85)	13.8 (.95)	14.5 (1.0)	15.8 (1.09)						
	072	12.3 (.85)	12.3 (.85)	12.3 (.85)	14.5 (1.0)	15.2 (1.05)						
085	13.1 (.90)	13.1 (.90)	14.5 (1.0)									

Inlet pressure is measured at inlet flange with petroleum base fluids at viscosity between 60 and 300 SUS (10 and 65 cSt). The difference between inlet pressure at the pump flange and atmosphere must not exceed 2.9 psi (.20 BAR) to prevent aeration.

Multiply absolute pressure by: 1.25 for HF-3, HF-4 fluids
 1.35 for HF-5 fluid.
 1.10 for ester and rapeseed base fluids.

Use the cartridge with the highest absolute pressure for double and triple pumps.



MINIMUM ALLOWABLE INLET PRESSURE [PSI (BAR) ABSOLUTE] PT6/PT7 SERIES MOBILE APPLICATIONS

Cartridges		Speed (RPM)							
Sizes	Disp	1200	1500	1800	2100	2200	2300	2500	2800
CM CP	B03	11.6 (.80)	11.6 (.80)	11.6 (.80)	11.6 (.80)	11.6 (.80)	11.6 (.80)	13.0 (.89)	14.5 (1.0)
	B05	11.6 (.80)	11.6 (.80)	11.6 (.80)	11.6 (.80)	11.6 (.80)	11.6 (.80)	13.0 (.89)	14.5 (1.0)
	B06	11.6 (.80)	11.6 (.80)	11.6 (.80)	11.6 (.80)	11.6 (.80)	11.6 (.80)	13.0 (.89)	14.5 (1.0)
	B08	11.6 (.80)	11.6 (.80)	11.6 (.80)	11.6 (.80)	11.6 (.80)	11.6 (.80)	13.0 (.89)	14.5 (1.0)
	B10	11.6 (.80)	11.6 (.80)	11.6 (.80)	11.6 (.80)	11.6 (.80)	11.6 (.80)	13.0 (.89)	14.5 (1.0)
	B12	11.6 (.80)	11.6 (.80)	11.6 (.80)	11.6 (.80)	11.6 (.80)	12.3 (.85)	13.3 (.92)	14.5 (1.0)
	B14	11.6 (.80)	11.6 (.80)	11.6 (.80)	11.6 (.80)	11.6 (.80)	12.3 (.85)	13.7 (.94)	14.5 (1.0)
	B17	11.6 (.80)	11.6 (.80)	11.6 (.80)	11.6 (.80)	12.3 (.85)	13.0 (.89)	13.7 (.94)	14.9 (1.03)
	B20	11.6 (.80)	11.6 (.80)	11.6 (.80)	11.6 (.80)	12.3 (.85)	13.0 (.89)	13.7 (.94)	14.9 (1.03)
	B22	11.6 (.80)	11.6 (.80)	11.6 (.80)	12.3 (.85)	13.0 (.89)	13.0 (.89)	14.2 (.98)	15.2 (1.05)
	B25	11.6 (.80)	11.6 (.80)	11.6 (.80)	13.0 (.89)	13.7 (.94)	13.7 (.94)	15.2 (1.05)	
	B28	11.6 (.80)	11.6 (.80)	11.6 (.80)	13.0 (.89)	14.5 (1.0)	14.5 (1.0)	15.7 (1.08)	
	B31	11.6 (.80)	11.6 (.80)	11.6 (.80)	12.3 (.85)	13.0 (.89)	14.5 (1.0)	16.1 (1.11)	
	DM DP	B14	11.6 (.80)	11.6 (.80)	11.6 (.80)	11.6 (.80)	12.8 (.88)	13.7 (.94)	14.5 (1.0)
B17		11.6 (.80)	11.6 (.80)	11.6 (.80)	11.6 (.80)	12.8 (.88)	13.7 (.94)	14.5 (1.0)	
B20		11.6 (.80)	11.6 (.80)	11.6 (.80)	11.6 (.80)	12.8 (.88)	13.7 (.94)	14.5 (1.0)	
B24		11.6 (.80)	11.6 (.80)	11.6 (.80)	11.9 (.82)	12.8 (.88)	13.7 (.94)	15.9 (1.09)	
B28		11.6 (.80)	11.6 (.80)	11.6 (.80)	12.3 (.85)	13.3 (.92)	14.5 (1.0)	17.1 (1.18)	
B31		11.6 (.80)	11.6 (.80)	11.6 (.80)	13.0 (.89)	13.7 (.94)	14.5 (1.0)	17.8 (1.23)	
B35		11.6 (.80)	11.6 (.80)	11.6 (.80)	13.3 (.92)	14.2 (.98)	14.8 (1.02)	18.7 (1.29)	
B38		11.6 (.80)	11.6 (.80)	11.6 (.80)	13.7 (.94)	14.5 (1.0)	15.2 (1.05)	18.7 (1.29)	
B42		11.6 (.80)	11.6 (.80)	11.6 (.80)	13.7 (.94)	14.8 (1.02)	15.7 (1.08)		
B45		11.6 (.80)	11.6 (.80)	12.3 (.85)	14.2 (.98)	15.2 (1.05)			
B50		11.6 (.80)	11.6 (.80)	12.3 (.85)	14.8 (1.02)	15.8 (1.09)			
EM EP	042	11.6 (.80)	11.6 (.80)	11.6 (.80)	12.8 (.88)	14.5 (1.0)			
	045	11.6 (.80)	11.6 (.80)	11.6 (.80)	13.0 (.89)	14.5 (1.0)			
	050	11.6 (.80)	11.6 (.80)	11.6 (.80)	13.0 (.89)	14.5 (1.0)			
	052	11.6 (.80)	11.6 (.80)	11.6 (.80)	13.0 (.89)	14.5 (1.0)			
	062	11.6 (.80)	11.6 (.80)	12.3 (.85)	13.7 (.94)	14.5 (1.0)			
	066	12.3 (.85)	12.3 (.85)	13.7 (.94)	14.5 (1.0)	15.8 (1.09)			
	072	12.3 (.85)	12.3 (.85)	12.3 (.85)	14.5 (1.0)	15.2 (1.05)			

Minimum Inlet Pressure: Please read the charts in this catalog as the minimum requested inlet pressure varies versus the displacement and speed. Never go under 11.6 psi Absolute (-2.9 psig)

Maximum Inlet Pressure: It is recommended to have at least 22 psi differential between inlet and outlet. Standard shaft seals are limited to 10 psig. Consult Support@permco.com for more information.

Minimum Outlet Pressure: It is recommended to have at least 22 psi differential between inlet and outlet.

Vertical Mount: When assembled vertically, be careful to prevent any air from being trapped in the pump especially behind the shaft seal.

Inlet pressure is measured at inlet flange with petroleum based fluids at viscosity between 60 and 300 SUS (10 and 65 cSt). The difference between inlet pressure at the pump flange and atmosphere must not exceed 2.9 psi (.20 BAR) to prevent aeration.

Multiply absolute pressure by : 1.25 for HF-3, HF-4 fluids
1.35 for HF-5 fluid.
1.10 for ester and rapeseed base fluids.

Use the cartridge with the highest absolute pressure for double and triple pumps.

PT6C - * 014 - 1 R 00 - B 1 *
 ① ② ③ ④ ⑤ ⑥ ⑦ ⑧ ⑨

① **Series** PT6C - SAE-B 2-Bolt Mount

② **Y-Metric port connection,**
Omit for UNC

③ **Cam Ring**

Volumetric displacement in³/ rev (cm³/rev)

003 = 0.66 (10.8)	017 = 3.56 (58.3)
005 = 1.05 (17.2)	020 = 3.89 (63.8)
006 = 1.30 (21.3)	022 = 4.29 (70.3)
008 = 1.61 (26.4)	025 = 4.84 (79.3)
010 = 2.08 (34.1)	028 = 5.42 (88.8)
012 = 2.26 (37.1)	031 = 6.10 (100.0)
014 = 2.81 (46.0)	

④ **Type of Shaft**

- 1 = Keyed (SAE-B)
- 2 = Keyed (No SAE)
- 3 = Splined (SAE-B)
- 4 = Splined (SAE-BB)
- 5 = Keyed (SAE-BB)

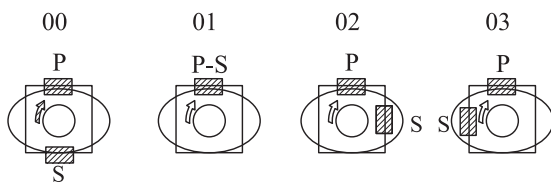

S = Suction port P = Pressure port

⑤ **Rotation**
(viewed from shaft end)

- R= clockwise
- L= counter-clockwise

⑥ **Porting Combination**
00= Standard

⑦ **Design Letter**

⑧ **Seal Class**

- 1= S1 HNBR (for mineral oil)
- 4= S4 EPDM (for fire resistant fluids)
- 5= S5 Viton (for mineral oil and fire resistant fluids)

⑨ **Modifications**

INTERNAL LEAKAGE (TYPICAL)

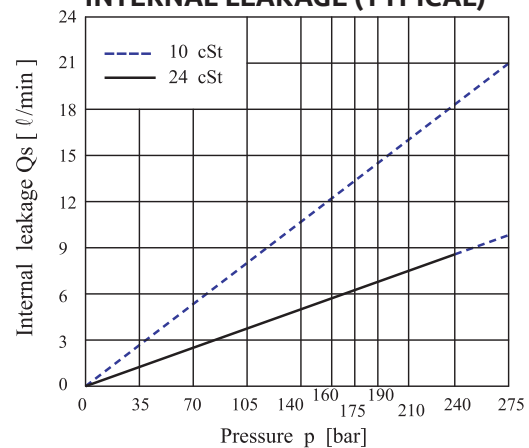

Do not operate pump more than 5 seconds at any speed or viscosity if internal leakage is more than 50% of theoretical flow.

HYDROMECHANICAL POWER LOSS (TYPICAL)

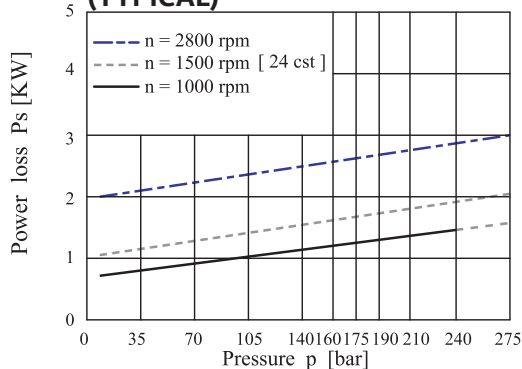

PERMISSIBLE RADIAL LOAD

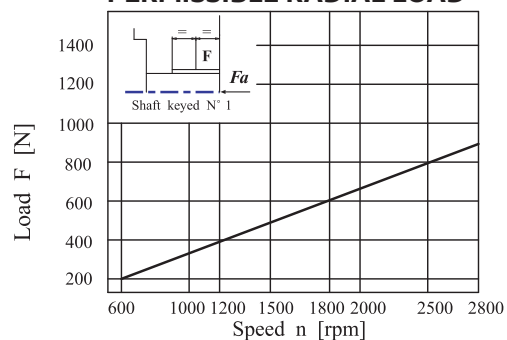

Maximum permissible axial load Fa=800 N



PT6C Dimensional Drawing

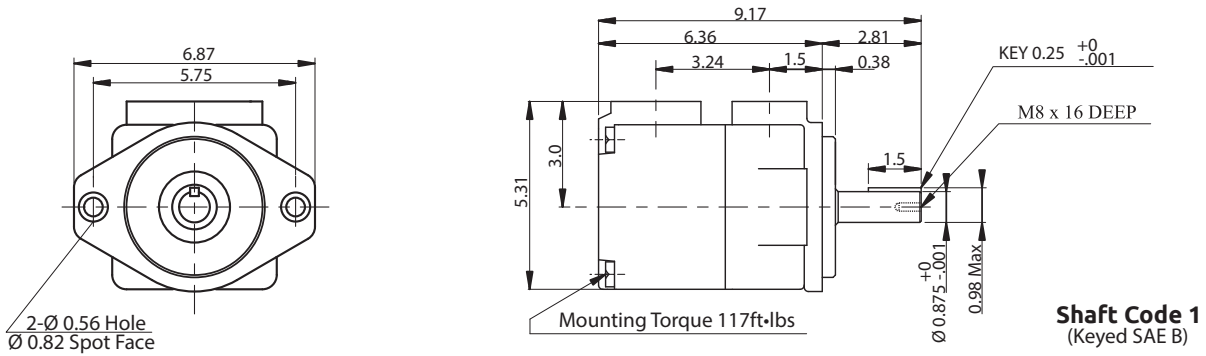

Shaft Code 1
(Keyed SAE B)

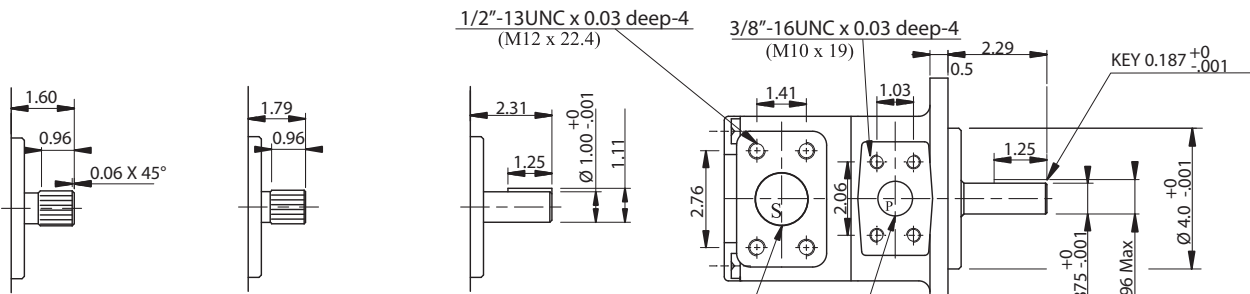

Shaft Code 3
SAE B splined shaft
J498 16/32
dp. -13 teeth 30°
pressure angle flat
root side fit

Shaft Code 4
SAE BB splined shaft
J498 16/32
dp. -15 teeth 30°
pressure angle flat
root side fit

Shaft Code 5
SAE BB keyed shaft

Shaft Code 2
(Keyed non SAE)

Shaft torque limits in ³ /rev x PSI (cm ³ /rev x Bar)		
Pump	Shaft	Vp x p max
PT6C	1	14473 (16500)
	2	12666 (14300)
	3	18246 (20600)
	4	19309 (21812)
	5	18246 (20600)

PT6C OPERATING CHARACTERISTICS - TYPICAL 115 SUS (24 cSt)

Series	Volumetric Displacement in ³ /rev (cm ³ /rev)	Speed n[RPM]	Flow Q in GPM (l/min)			Input Power HP (KW)			P. Max PSI (Bar)	MAX RPM
			p = 0 PSI (0 Bar)	p = 2000 PSI (140 Bar)	p = 3500 PSI (240 Bar)	p = 100 PSI (7 Bar)	p = 2000 PSI (140 Bar)	p = 3500 PSI (240 Bar)		
003	0.66 (10.8)	1000	2.85 (10.8)	1.98 (7.5)	1.35 (5.1)	1.21 (0.9)	4.83 (3.6)	7.64 (5.70)	4000 (275)	2800
		1500	4.28 (16.2)	2.96 (11.2)	2.03 (7.7)	1.74 (1.3)	7.11 (5.3)	15.10 (11.26)		
005	1.05 (17.2)	1000	4.54 (17.2)	3.67 (13.9)	3.04 (11.5)	1.34 (1.0)	6.84 (5.1)	11.13 (8.30)		
		1500	6.82 (25.8)	5.49 (20.8)	4.57 (17.3)	1.88 (1.4)	10.06 (7.5)	16.36 (12.20)		
006	1.30 (21.3)	1000	5.63 (21.3)	4.31 (16.3)	3.38 (12.8)	1.48 (1.1)	8.05 (6.0)	13.41 (10.00)		
		1500	8.43 (31.9)	7.11 (26.9)	6.18 (23.4)	2.01 (1.5)	11.94 (8.9)	19.71 (14.70)		
008	1.61 (26.4)	1000	6.97 (26.4)	5.65 (21.4)	4.73 (17.9)	1.61 (1.2)	9.66 (7.2)	16.23 (12.10)		
		1500	10.46 (39.6)	9.14 (34.6)	8.22 (31.1)	2.15 (1.6)	14.35 (10.7)	23.74 (17.70)		
010	2.08 (34.1)	1000	9.01 (34.1)	7.69 (29.1)	6.76 (25.6)	1.74 (1.3)	11.94 (8.9)	20.25 (15.10)		
		1500	13.50 (51.1)	12.18 (46.1)	11.25 (42.6)	2.28 (1.7)	17.97 (13.4)	29.90 (22.30)		
012	2.26 (37.1)	1000	9.80 (37.1)	8.48 (32.1)	7.56 (28.6)	1.74 (1.3)	12.87 (9.6)	21.86 (16.30)		
		1500	14.69 (55.6)	13.37 (50.6)	12.44 (47.1)	2.28 (1.7)	19.31 (14.4)	32.32 (24.10)		
014	2.81 (46.0)	1000	12.15 (46.0)	10.83 (41.0)	9.91 (37.5)	1.88 (1.4)	15.69 (11.7)	26.69 (19.90)		
		1500	18.23 (69.0)	16.91 (64.0)	15.98 (60.5)	2.55 (1.9)	23.60 (17.6)	39.56 (29.50)		
017	3.56 (58.3)	1000	15.40 (58.3)	14.08 (53.3)	13.16 (49.8)	2.15 (1.6)	19.44 (14.5)	33.26 (24.80)		
		1500	23.09 (87.4)	21.77 (82.4)	20.84 (78.9)	2.82 (2.1)	29.37 (21.9)	49.48 (36.90)		
020	3.89 (63.8)	1000	16.85 (63.8)	15.53 (58.8)	14.61 (55.3)	2.15 (1.6)	21.20 (15.8)	36.21 (27.00)		
		1500	25.28 (95.7)	23.96 (90.7)	23.04 (87.2)	2.95 (2.2)	31.92 (23.8)	53.91 (40.20)		
022	4.29 (70.3)	1000	18.57 (70.3)	17.25 (65.3)	16.33 (61.8)	2.28 (1.7)	23.20 (17.3)	39.69 (29.60)		
		1500	27.84 (105.4)	26.42 (100.0)	25.60 (96.9)	3.08 (2.3)	35.00 (26.1)	59.14 (44.10)		
025 ⁽¹⁾	4.84 (79.3)	1000	20.95 (79.3)	19.63 (74.3)	18.70 (70.8)	2.41 (1.8)	25.88 (19.3)	44.52 (33.20)		
		1500	31.41 (118.9)	30.09 (113.9)	29.16 (110.4)	3.35 (2.5)	39.16 (29.2)	66.38 (49.50)		
028 ⁽¹⁾	5.42 (88.8)	1000	23.46 (88.8)	22.14 (83.8)	21.50 (81.4 (2)	2.55 (1.9)	29.37 (21.9)	43.58 (32.50 (2)		
		1500	35.19 (133.2)	33.87 (128.2)	33.23 (125.8 (2)	3.75 (2.8)	43.85 (32.7)	65.04 (48.50 (2)		
031 ⁽¹⁾	6.10 (100.0)	1000	26.42 (100.0)	25.10 (95.0)	24.46 (92.6 (2)	2.68 (2.0)	32.72 (24.4)	48.81 (36.40 (2)		
		1500	39.63 (150.0)	38.30 (145.0)	37.67 (142.6 (2)	3.75 (2.8)	48.95 (36.5)	72.95 (54.40 (2)		

(1) 025 - 028 - 031 = 2500 RPM max

(2) 028 - 031 = 3062 PSI max. int.

Min Speed : 600 RPM

PT6CM - * B14- 1 R 00 - C 1 *
 ① ② ③ ④ ⑤ ⑥ ⑦ ⑧ ⑨

① **Series** PT6CM - SAE-B 2 Bolt Mount

② **Y-Metric port connection,**
Omit for UNC

③ **Cam Ring**
Volumetric displacement in³/rev (cm³/rev)

B03 = 0.66 (10.8)	B17 = 3.56 (58.3)
B05 = 1.05 (17.2)	B20 = 3.89 (63.8)
B06 = 1.30 (21.3)	B22 = 4.29 (70.3)
B08 = 1.61 (26.4)	B25 = 4.84 (79.3)
B10 = 2.08 (34.1)	B28 = 5.42 (88.8)
B12 = 2.26 (37.1)	B31 = 6.10 (100.0)
B14 = 2.81 (46.0)	

④ **Type of Shaft**

- 1 = Keyed (SAE-B)
- 2 = Keyed (No SAE)
- 3 = Splined (SAE-B)
- 4 = Splined (SAE-BB)
- 5 = Keyed (SAE-BB)

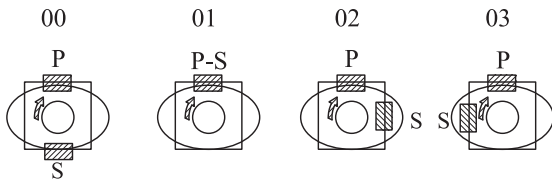

S = Suction port P = Pressure port

⑤ **Rotation**
(viewed from shaft end)
R = clockwise
L = counter-clockwise

⑥ **Porting Combination**
00=Standard

⑦ **Design Letter**

⑧ **Seal Class**

- 1= S1 HNBR (for mineral oil)
- 4= S4 EPDM (for fire resistant fluids)
- 5= S5 Viton (for mineral oil and fire resistant fluids)

⑨ **Modifications**

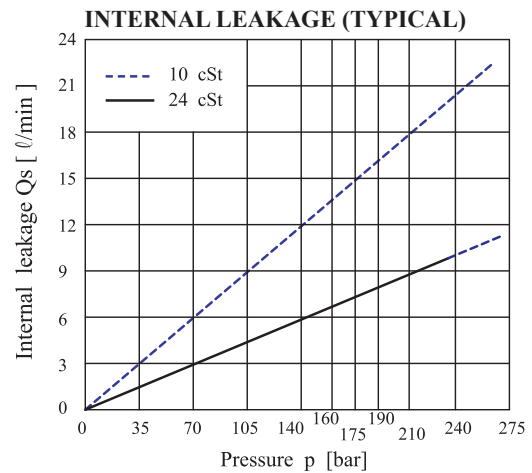

Do not operate pump more than 5 seconds at any speed or viscosity if internal leakage is more than 50% of theoretical flow.

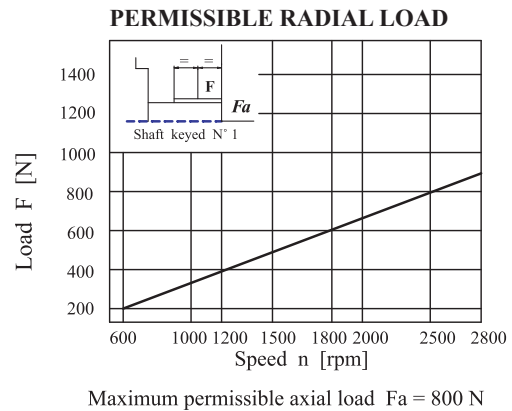
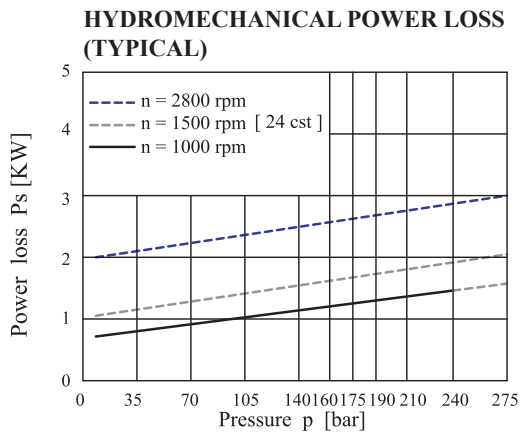



PT6CM Dimensional Drawing

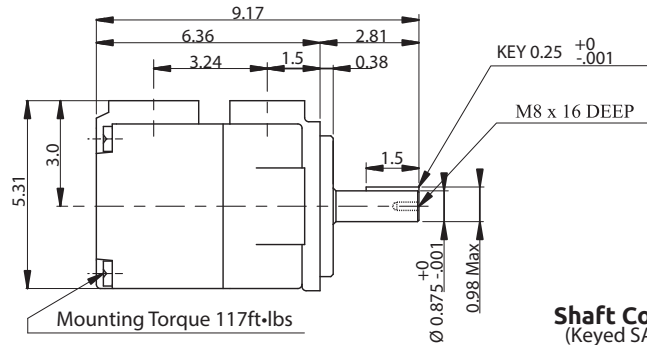
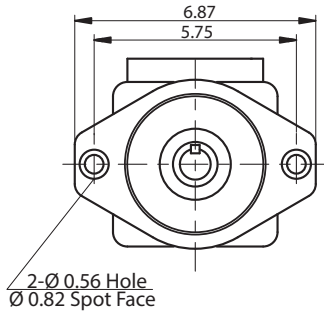

Shaft Code 1
(Keyed SAE B)

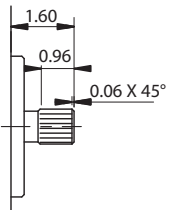

Shaft Code 3
SAE B splined shaft
J498 16/32
dp. -13 teeth 30°
pressure angle flat
root side fit

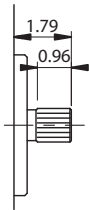

Shaft Code 4
SAE BB splined shaft
J498 16/32
dp. -15 teeth 30°
pressure angle flat
root side fit

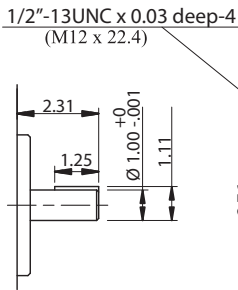

Shaft Code 5
SAE BB keyed shaft

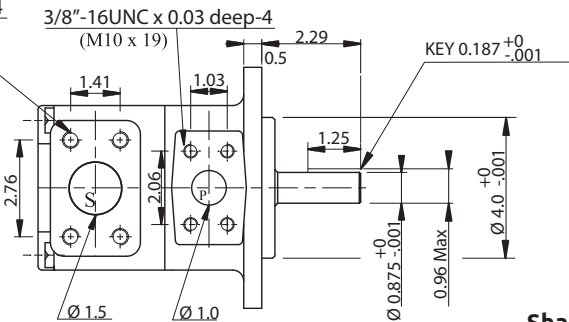

Shaft Code 2
(Keyed non SAE)

Shaft torque limits in ³ /rev x PSI (cm ³ /rev x Bar)		
Pump	Shaft	Vp x p max
PT6CM	1	14473 (16500)
	2	12666 (14300)
	3	18246 (20600)
	4	19309 (21812)
	5	18246 (20600)

PT6CM OPERATING CHARACTERISTICS - TYPICAL 115 SUS (24 cSt)

Series	Volumetric Displacement in ³ /rev (cm ³ /rev)	Speed n[RPM]	Flow Q in GPM (l/min)			Input Power HP (KW)			P. Max PSI (Bar)	MAX RPM
			p = 0 PSI (0 Bar)	p = 2000 PSI (140 Bar)	p = 3500 PSI (240 Bar)	p = 100 PSI (7 Bar)	p = 2000 PSI (140 Bar)	p = 3500 PSI (240 Bar)		
B03	0.66 (10.8)	1000	2.85 (10.8)	1.88 (7.1)	()	1.21 (0.9)	4.83 (3.6)	()	4000 (275)	2800
		1500	4.28 (16.2)	2.83 (10.7)	()	1.74 (1.3)	7.11 (5.3)	()		
B05	1.05 (17.7)	1000	4.54 (17.2)	3.57 (13.5)	2.77 (10.5)	1.34 (1.0)	6.84 (5.1)	11.13 (8.3)		
		1500	6.82 (25.8)	5.36 (20.3)	4.17 (15.8)	1.88 (1.4)	10.06 (7.5)	16.36 (12.2)		
B06	1.30 (21.3)	1000	5.63 (21.3)	4.68 (17.7)	3.88 (14.7)	1.48 (1.1)	8.05 (6.0)	13.41 (10.0)		
		1500	8.43 (31.9)	7.00 (26.5)	5.81 (22.0)	2.01 (1.5)	11.94 (8.9)	19.71 (14.7)		
B08	1.61 (26.4)	1000	6.97 (26.4)	6.00 (22.7)	5.20 (19.7)	1.61 (1.2)	9.66 (7.2)	16.23 (12.1)		
		1500	10.46 (39.6)	9.01 (34.1)	7.82 (29.6)	2.15 (1.6)	14.35 (10.7)	23.74 (17.7)		
B10	2.08 (34.1)	1000	9.01 (34.1)	8.06 (30.5)	6.76 (25.6)	1.74 (1.3)	11.94 (8.9)	20.25 (15.1)		
		1500	13.50 (51.1)	12.07 (45.7)	10.88 (41.2)	2.28 (1.7)	17.97 (13.4)	29.90 (22.3)		
B12	2.26 (37.1)	1000	9.80 (37.1)	8.85 (33.5)	7.26 (27.5)	1.74 (1.3)	12.87 (9.6)	21.86 (16.3)		
		1500	14.69 (55.6)	13.26 (50.2)	12.07 (45.7)	2.28 (1.7)	19.31 (14.4)	32.32 (24.1)		
B14	2.81 (46.0)	1000	12.15 (46.0)	11.17 (42.3)	10.38 (39.3)	1.88 (1.4)	15.69 (11.7)	26.69 (19.9)		
		1500	18.23 (69.0)	16.77 (63.5)	15.59 (59.0)	2.55 (1.9)	23.60 (17.6)	39.56 (29.5)		
B17	3.56 (58.3)	1000	15.40 (58.3)	14.45 (54.7)	13.63 (51.6)	2.15 (1.6)	19.44 (14.5)	33.26 (24.8)		
		1500	23.09 (87.4)	21.66 (82.0)	20.47 (77.5)	2.82 (2.1)	29.37 (21.9)	49.48 (36.9)		
B20	3.89 (63.8)	1000	16.85 (63.8)	15.88 (60.1)	15.08 (57.1)	2.15 (1.6)	21.20 (15.8)	36.21 (27.0)		
		1500	25.28 (95.7)	23.83 (90.2)	22.64 (85.7)	2.95 (2.2)	31.92 (23.8)	53.91 (40.2)		
B22	4.29 (70.3)	1000	18.57 (70.3)	17.62 (66.7)	16.80 (63.6)	2.28 (1.7)	23.20 (17.3)	39.69 (29.6)		
		1500	27.84 (105.4)	26.42 (100.0)	25.23 (95.5)	3.08 (2.3)	35.00 (26.1)	59.14 (44.1)		
B25 ₍₁₎	4.84 (79.3)	1000	20.95 (79.3)	20.00 (75.7)	19.18 (72.6)	2.41 (1.8)	25.88 (19.3)	44.52 (33.2)		
		1500	31.41 (118.9)	29.98 (113.5)	28.79 (109.0)	3.35 (2.5)	39.16 (29.2)	66.38 (49.5)		
B28 ₍₁₎	5.42 (88.8)	1000	23.46 (88.8)	21.93 (83.0)	21.50 (81.4 (2)	2.55 (1.9)	29.37 (21.9)	43.58 (32.5)		
		1500	35.19 (133.2)	33.73 (127.7)	33.15 (125.5 (2)	3.75 (2.8)	43.85 (32.7)	65.04 (48.5 (2)		
B31 ₍₁₎	6.10 (100.0)	1000	26.42 (100.0)	25.44 (96.3)	24.89 (94.2 (2)	2.68 (2.0)	32.72 (24.4)	48.81 (36.4 (2)		
		1500	39.63 (150.0)	38.17 (144.5)	37.33 (141.3 (2)	3.75 (2.8)	48.95 (36.5)	72.95 (54.4 (2)		

(1) 025 - 028 - 031 = 2500 RPM max

(2) 028 - 031 = 3000 PSI max. int.

Min Speed : 600 RPM

PT6D * - 045 - 1 R 00 - B 1 *
 ① ② ③ ④ ⑤ ⑥ ⑦ ⑧ ⑨

① **Series** PT6D - SAE-C 2 Bolt

② **Y-Metric port connection**
Omit for UNC

③ **Cam Ring**
Volumetric displacement in ³/rev (cm³/rev)

014 = 2.90 (47.6)	035 = 6.77 (111.0)
017 = 3.55 (58.2)	038 = 7.34 (120.3)
020 = 4.03 (66.0)	042 = 8.30 (136.0)
024 = 4.85 (79.5)	045 = 8.89 (145.7)
028 = 5.47 (89.7)	050 = 9.64 (158.0)
031 = 6.00 (98.3)	

④ **Type of Shaft**

- 1 = Keyed (SAE C)
- 2 = Keyed (No SAE)
- 3 = Splined (SAE C)
- 4 = Splined (SAE C spec long)

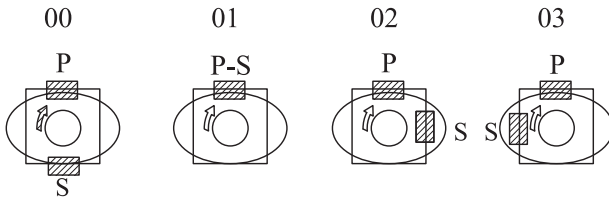

S = Suction port P = Pressure port

⑤ **Rotation**
(viewed from shaft end)
R= clockwise
L= counter-clockwise

⑥ **Porting Combination**
00=Standard

⑦ **Design Letter**

⑧ **Seal Class**

- 1= S1 HNBR (for mineral oil)
- 4= S4 EPDM (for fire resistant fluids)
- 5= S5 Viton (for mineral oil and fire resistant fluids)

⑨ **Modifications**

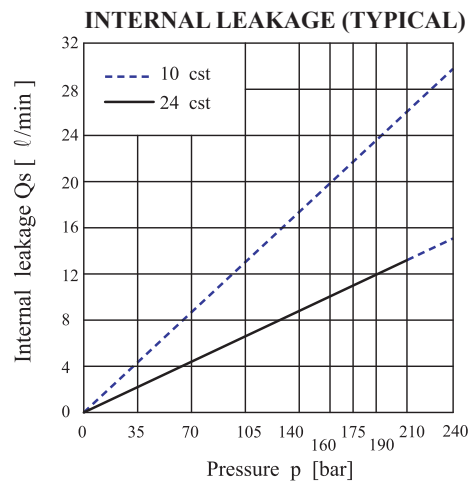

Do not operate pump more than 5 seconds at any speed or viscosity if internal leakage is more than 50% of theoretical flow.

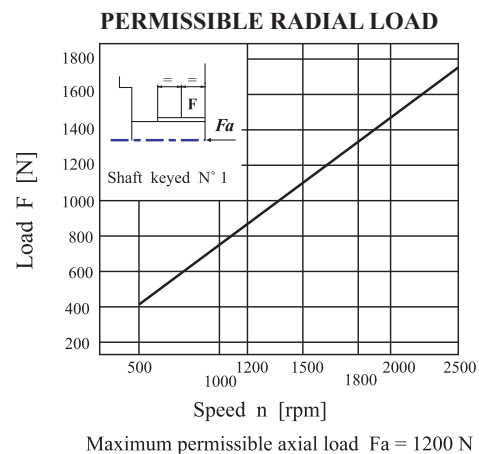
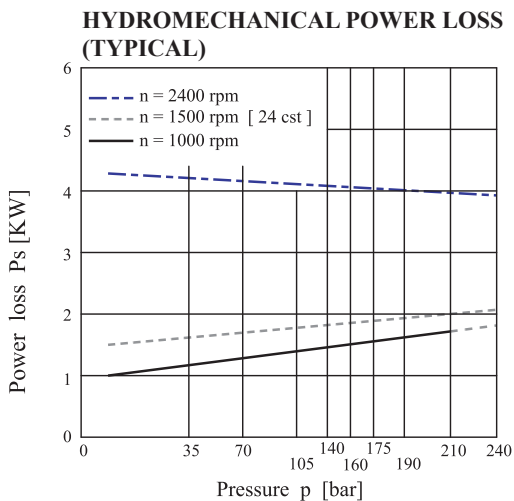



PT6D Dimensional Drawing

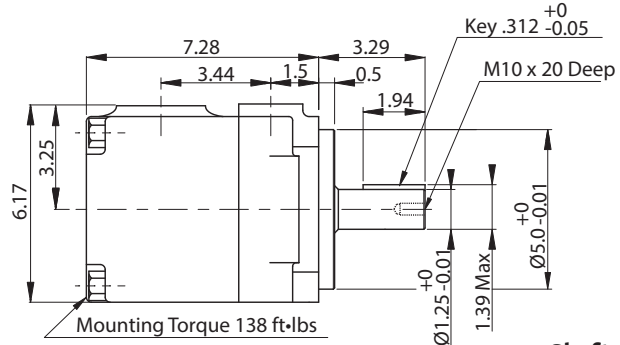
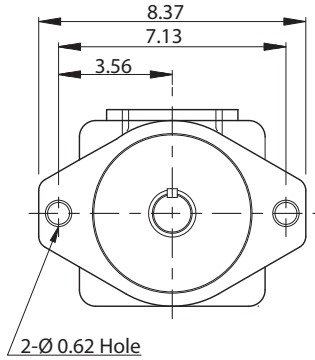

Shaft Code 1
(Keyed SAE C)

7/16"-14UNC x 0.88deep-4

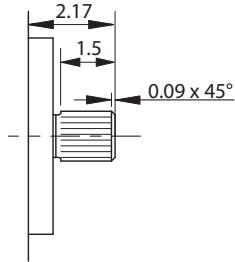

Shaft Code 3
SAE C Splined Shaft
12/24 dp. - 14 teeth
30° pressure angle
Flat root side fit

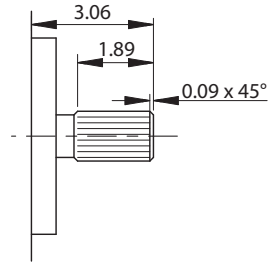

Shaft Code 4
SAE C Splined Spec Long
12/24 dp. - 14 teeth
30° pressure angle
Flat root side fit

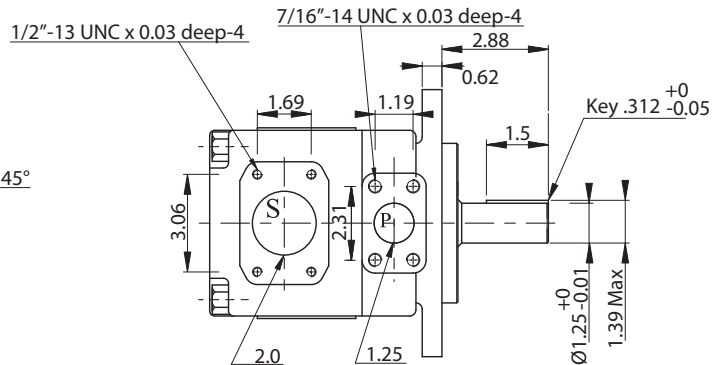

Shaft Code 2
(Keyed no SAE)

Shaft torque limits in ³ /rev x PSI (cm ³ /rev x Bar)		
Pump	Shaft	Vp x p max
PT6D	1	38299 (43283)
	2	30638 (34590)
	3	54207 (61200)
	4	54207 (61200)

PT6D OPERATING CHARACTERISTICS - TYPICAL 115 SUS (24 cSt)

Series	Volumetric Displacement in ³ /rev (cm ³ /rev)	Speed n(RPM)	Flow Q in GPM (l/min)			Input Power HP (KW)			P. Max PSI (Bar)	MAX RPM
			p = 0 PSI (0 Bar)	p = 2000 PSI (140 Bar)	p = 3500 PSI (240 Bar)	p = 100 PSI (7 Bar)	p = 2000 PSI (140 Bar)	p = 3500 PSI (240 Bar)		
014	2.90 (47.6)	1000	12.57 (47.6)	10.12 (38.3)	8.48 (32.1)	2.01 (1.5)	16.76 (12.5)	27.76 (20.70)	3500 (240)	2500
		1500	18.86 (71.4)	16.41 (62.1)	14.77 (55.9)	3.08 (2.3)	24.81 (18.5)	41.04 (30.60)		
017	3.55 (58.2)	1000	15.37 (58.2)	13.74 (52.0)	12.63 (47.8)	2.15 (1.6)	19.85 (14.8)	32.99 (24.60)		
		1500	23.06 (87.3)	20.61 (78.0)	18.97 (71.8)	3.35 (2.5)	29.77 (22.2)	49.62 (37.00)		
020	4.03 (66.0)	1000	17.44 (66.0)	14.98 (56.7)	13.34 (50.5)	2.28 (1.7)	22.53 (16.8)	37.55 (28.00)		
		1500	26.15 (99.0)	23.70 (89.7)	22.06 (83.5)	3.75 (2.8)	33.39 (24.9)	55.92 (41.70)		
024	4.85 (79.5)	1000	21.00 (79.5)	18.54 (70.2)	16.91 (64.0)	2.55 (1.9)	26.69 (19.9)	44.79 (33.40)		
		1500	31.52 (119.3)	29.06 (110.0)	27.42 (103.8)	4.02 (3.0)	39.69 (29.6)	66.78 (49.80)		
028	5.47 (89.7)	1000	23.70 (89.7)	21.24 (80.4)	19.60 (74.2)	2.68 (2.0)	29.90 (22.3)	50.29 (37.50)		
		1500	35.53 (134.5)	33.07 (125.2)	31.44 (119.0)	4.29 (3.2)	44.52 (33.2)	74.96 (55.90)		
031	6.00 (98.3)	1000	25.97 (98.3)	23.51 (89.0)	21.87 (82.8)	2.82 (2.1)	32.59 (24.3)	54.85 (40.90)		
		1500	38.97 (147.5)	36.48 (138.1)	34.84 (131.9)	4.43 (3.3)	48.54 (36.2)	81.80 (61.00)		
035	6.77 (111.0)	1000	29.32 (111.0)	26.87 (101.7)	25.23 (95.5)	3.08 (2.3)	36.61 (27.3)	61.69 (46.00)		
		1500	43.98 (166.5)	41.53 (157.2)	39.89 (151.0)	4.69 (3.5)	54.58 (40.7)	92.13 (68.70)		
038	7.34 (120.3)	1000	31.78 (120.3)	29.32 (111.0)	27.69 (104.8)	3.22 (2.4)	39.43 (29.4)	66.78 (49.80)		
		1500	47.66 (180.4)	45.20 (171.1)	43.56 (164.9)	4.96 (3.7)	58.87 (43.9)	99.64 (74.30)		
042 ₍₁₎	8.30 (136.0)	1000	35.93 (136.0)	33.47 (126.7)	31.83 (120.5)	3.49 (2.6)	44.39 (33.1)	75.10 (56.00)		
		1500	53.89 (204.0)	51.43 (194.7)	49.80 (188.5)	5.36 (4.0)	66.25 (49.4)	112.24 (83.70)		
045 ₍₁₎	8.89 (145.7)	1000	38.49 (145.7)	36.03 (136.4)	34.40 (130.2)	3.62 (2.7)	47.34 (35.3)	80.33 (59.90)		
		1500	57.72 (218.5)	55.26 (209.2)	53.63 (203.0)	5.50 (4.1)	70.81 (52.8)	120.02 (89.50)		
050 ₍₁₎	9.64 (158.0)	1000	41.74 (158.0)	39.28 (148.7)	38.30 (145.0 (2))	3.75 (2.8)	51.23 (38.2)	76.17 (56.80 (2))		
		1500	62.61 (237.0)	60.15 (227.7)	59.17 (224.0 (2))	5.90 (4.4)	76.44 (57.0)	113.99 (85.00 (2))		

(1)042 - 045 - 050 = 2200 RPM max

(2) 050 = 3062 PSI max. int.

Min Speed : 600 RPM

PT6DM * - B45- 1 R 00 - C 1 *

① ② ③ ④ ⑤ ⑥ ⑦ ⑧ ⑨

① **Series** PT6DM - SAE-C 2-Bolt Mount

② **Y-Metric port connection** (not for code Q)
Omit for UNC

③ **Cam Ring**
Volumetric displacement in³/ rev (cm³/rev)

B14 = 2.90 (47.6)	B35 = 6.77 (111.0)
B17 = 3.55 (58.2)	B38 = 7.34 (120.3)
B20 = 4.03 (66.0)	B42 = 8.30 (136.0)
B24 = 4.85 (79.5)	B45 = 8.89 (145.7)
B28 = 5.47 (89.7)	B50 = 9.64 (158.0)
B31 = 6.00 (98.3)	

④ **Type of Shaft**
1 = Keyed (SAE C)
2 = Keyed (No SAE)
3 = Splined (SAE C)
4 = Splined (SAE C spec long)

⑤ **Rotation**
(viewed from shaft end)

R = clockwise
L = counter-clockwise

⑥ **Porting Combination**
00 = Standard

⑦ **Design Letter**

⑧ **Seal Class**

1 = S1 HNBR (for mineral oil)
4 = S4 EPDM (for fire resistant fluids)
5 = S5 Viton (for mineral oil and fire resistant fluids)

⑨ **Modifications**

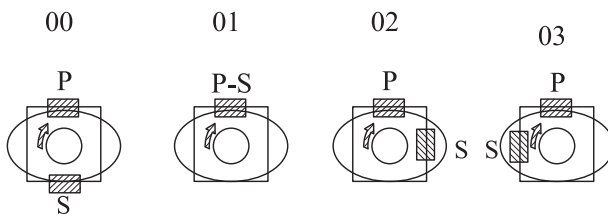

S = Suction port P = Pressure port

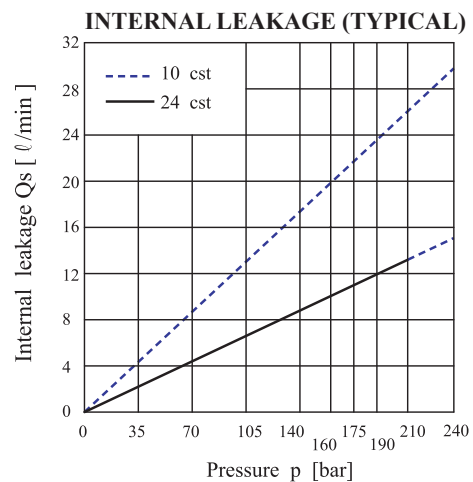

Do not operate pump more than 5 seconds at any speed or viscosity if internal leakage is more than 50% of theoretical flow.

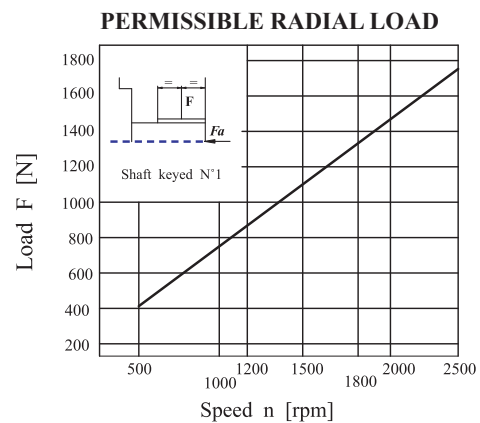
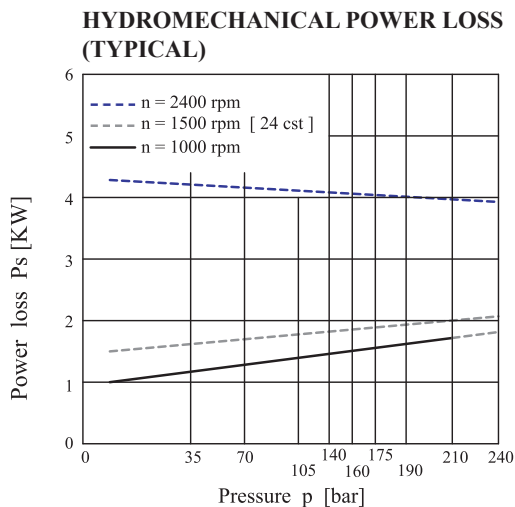

Maximum permissible axial load Fa = 1200 N



PT6DM Dimensional Drawing

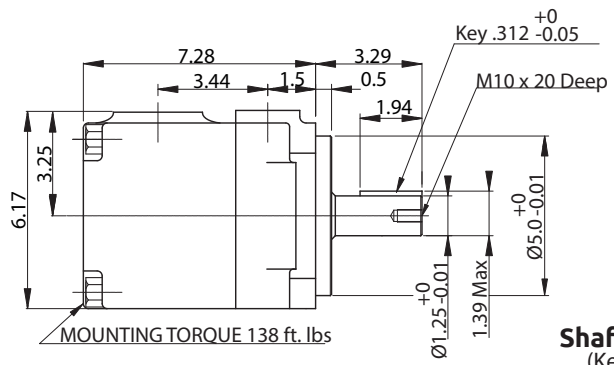
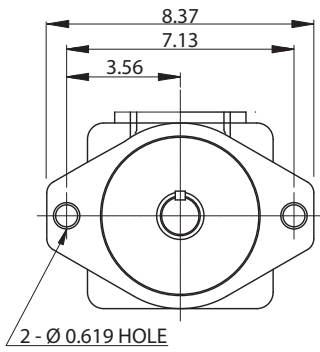

Shaft Code 1
(Keyed SAE C)

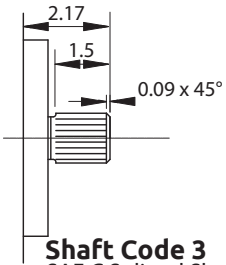

Shaft Code 3
SAE C Splined Shaft
12/24 dp. - 14 teeth
30° pressure angle
Flat root side fit

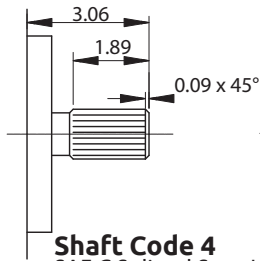

Shaft Code 4
SAE C Splined Spec Long
12/24 dp. - 14 teeth
30° pressure angle
Flat root side fit

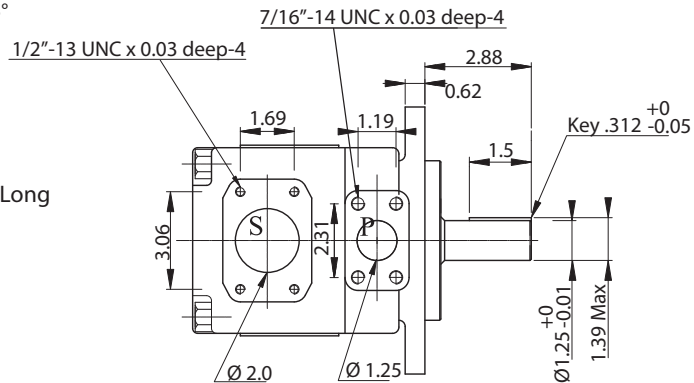

Shaft Code 2
(Keyed no SAE)

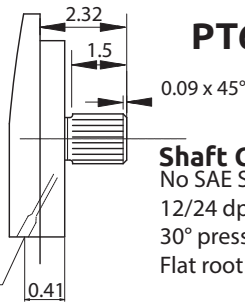

PT6DP

Shaft Code 3
No SAE Splined
12/24 dp. - 14 teeth
30° pressure angle
Flat root side fit

Drain hole between double shaft seals

Drain hole between double shaft seals

Shaft torque limits in ³ /rev x PSI (cm ³ /rev x Bar)		
Pump	Shaft	Vp x p max
PT6DM	1	38299 (43283)
	2	30638 (34590)
	3	54207 (61200)
	4	54207 (61200)

PT6DM OPERATING CHARACTERISTICS - TYPICAL 115 SUS (24 cSt)

Series	Volumetric Displacement in ³ /rev (cm ³ /rev)	Speed n[RPM]	Flow Q in GPM (l/min)			Input Power HP (KW)			P. Max PSI (Bar)	MAX RPM
			p = 0 PSI (0 Bar)	p = 2000 PSI (140 Bar)	p = 3500 PSI (240 Bar)	p = 100 PSI (7 Bar)	p = 2000 PSI (140 Bar)	p = 3500 PSI (240 Bar)		
B14	2.90 (47.6)	1000	12.57 (47.6)	10.12 (38.3)	8.48 (32.1)	2.01 (1.5)	16.76 (12.5)	27.76 (20.70)	3500 (240)	2500
		1500	18.86 (71.4)	16.41 (62.1)	14.77 (55.9)	3.08 (2.3)	24.81 (18.5)	41.04 (30.60)		
B17	3.55 (58.2)	1000	15.37 (58.2)	13.74 (52.0)	12.63 (47.8)	2.15 (1.6)	19.85 (14.8)	32.99 (24.60)		
		1500	23.06 (87.3)	20.61 (78.0)	18.97 (71.8)	3.35 (2.5)	29.77 (22.2)	49.62 (37.00)		
B20	4.03 (66.0)	1000	17.44 (66.0)	14.98 (56.7)	13.34 (50.5)	2.28 (1.7)	22.53 (16.8)	37.55 (28.00)		
		1500	26.15 (99.0)	23.70 (89.7)	22.06 (83.5)	3.75 (2.8)	33.39 (24.9)	55.92 (41.70)		
B24	4.85 (79.5)	1000	21.00 (79.5)	18.54 (70.2)	16.91 (64.0)	2.55 (1.9)	26.69 (19.9)	44.79 (33.40)		
		1500	31.52 (119.3)	29.06 (110.0)	27.42 (103.8)	4.02 (3.0)	39.69 (29.6)	66.78 (49.80)		
B28	5.47 (89.7)	1000	23.70 (89.7)	21.24 (80.4)	19.60 (74.2)	2.68 (2.0)	29.90 (22.3)	50.29 (37.50)		
		1500	35.53 (134.5)	33.07 (125.2)	31.44 (119.0)	4.29 (3.2)	44.52 (33.2)	74.96 (55.90)		
B31	6.00 (98.3)	1000	25.97 (98.3)	23.51 (89.0)	21.87 (82.8)	2.82 (2.1)	32.59 (24.3)	54.85 (40.90)		
		1500	38.97 (147.5)	36.48 (138.1)	34.84 (131.9)	4.43 (3.3)	48.54 (36.2)	81.80 (61.00)		
B35	6.77 (111.0)	1000	29.32 (111.0)	26.87 (101.7)	25.23 (95.5)	3.08 (2.3)	36.61 (27.3)	61.69 (46.00)		
		1500	43.98 (166.5)	41.53 (157.2)	39.89 (151.0)	4.69 (3.5)	54.58 (40.7)	92.13 (68.70)		
B38	7.34 (120.3)	1000	31.78 (120.3)	29.32 (111.0)	27.69 (104.8)	3.22 (2.4)	39.43 (29.4)	66.78 (49.80)		
		1500	47.66 (180.4)	45.20 (171.1)	43.56 (164.9)	4.96 (3.7)	58.87 (43.9)	99.64 (74.30)		
B42 ₍₁₎	8.30 (136.0)	1000	35.93 (136.0)	33.47 (126.7)	31.83 (120.5)	3.49 (2.6)	44.39 (33.1)	75.10 (56.00)		
		1500	53.89 (204.0)	51.43 (194.7)	49.80 (188.5)	5.36 (4.0)	66.25 (49.4)	112.24 (83.70)		
B45 ₍₁₎	8.89 (145.7)	1000	38.49 (145.7)	36.03 (136.4)	34.40 (130.2)	3.62 (2.7)	47.34 (35.3)	80.33 (59.90)		
		1500	57.72 (218.5)	55.26 (209.2)	53.63 (203.0)	5.50 (4.1)	70.81 (52.8)	120.02 (89.50)		
B50 ₍₁₎	9.64 (158.0)	1000	41.74 (158.0)	39.28 (148.7)	38.30 (145.0 (2)	3.75 (2.8)	51.23 (38.2)	76.17 (56.80 (2)	3062	2200
		1500	62.61 (237.0)	60.15 (227.7)	59.17 (224.0 (2)	5.90 (4.4)	76.44 (57.0)	113.99 (85.00 (2)	(210)	

(1)042 - 045 - 050 = 2200 RPM max

(2) 050 = 3062 PSI max. int.

Min Speed : 600 RPM

PT6DS/PT6DSM - 045 - 1 R 00 - B 1 *

① ② ③ ④ ⑤ ⑥ ⑦ ⑧

① **Series** PT6DS/PT6DSM - SAE-C 2 & 4 Bolt Mount

② **Cam Ring**
Volumetric displacement in³/rev (cm³/rev)
 014/B14 = 2.90 (47.6) 035/B35 = 6.77 (111.0)
 017/B17 = 3.55 (58.2) 038/B38 = 7.34 (120.3)
 020/B20 = 4.03 (66.0) 042/B42 = 8.30 (136.0)
 024/B24 = 4.85 (79.5) 045/B45 = 8.89 (145.7)
 028/B28 = 5.47 (89.7) 050/B50 = 9.64 (158.0)
 031/B31 = 6.00 (98.3)

③ **Type of Shaft**
 1 = Keyed (SAE C)
 2 = Keyed (SAE C spec short)
 3 = Splined (SAE C)
 4 = Splined (SAE C spec long)

④ **Rotation**
 (viewed from shaft end)
 R= clockwise
 L= counter-clockwise

⑤ **Porting Combination**
 00=Standard

⑥ **Design Letter**

⑦ **Seal Class**
 1= S1 HNBR (for mineral oil)
 4= S4 EPDM (for fire resistant fluids)
 5= S5 Viton (for mineral oil and fire resistant fluids)

⑧ **Modifications**

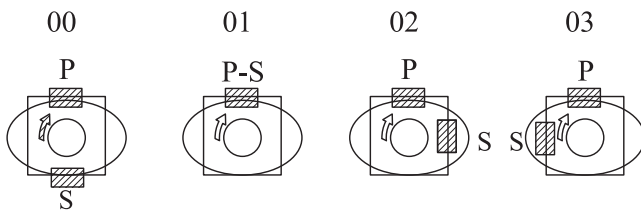

S = Suction port P = Pressure port

Do not operate pump more than 5 seconds at any speed or viscosity if internal leakage is more than 50% of theoretical flow.

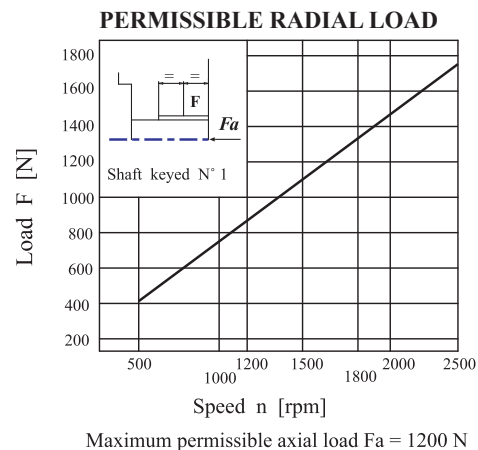
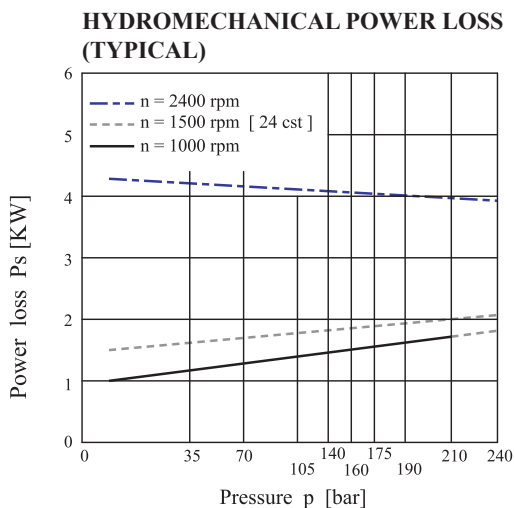
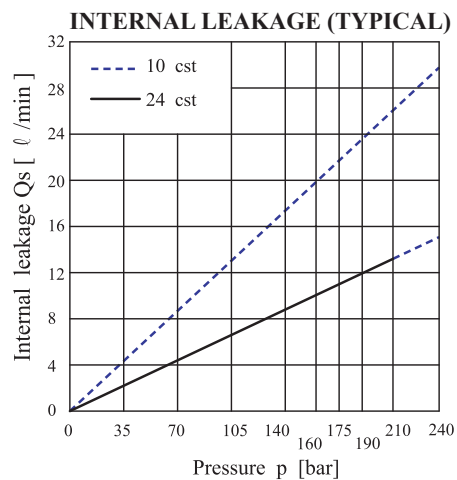



PT6DS Dimensional Drawing

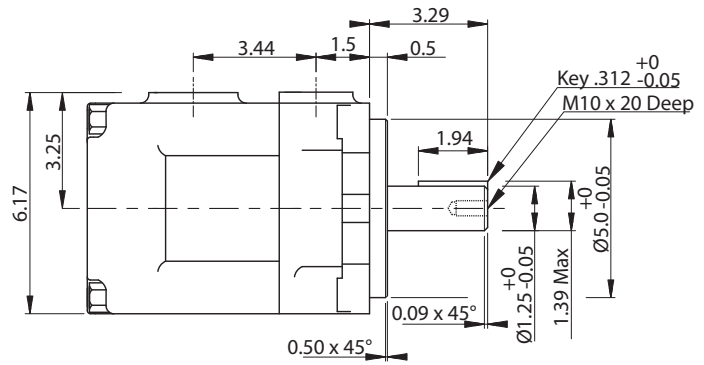
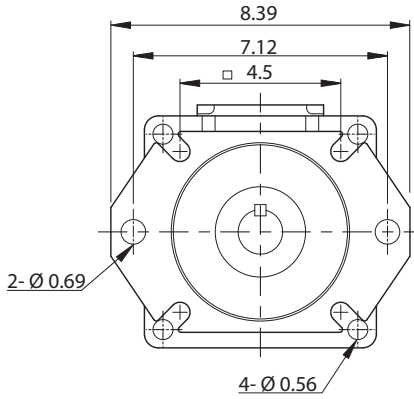

Shaft Code 1
(Keyed SAE C)

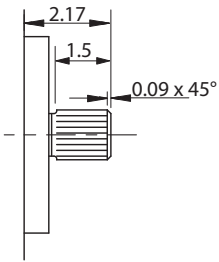

Shaft Code 3
SAE C Splined Shaft
12/24 dp. - 14 teeth
30° pressure angle
Flat root side fit

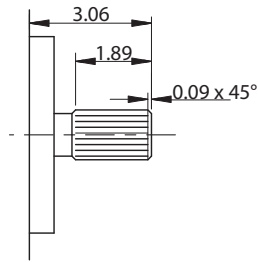

Shaft Code 4
SAE C Splined Spec Long
12/24 dp. - 14 teeth
30° pressure angle
Flat root side fit

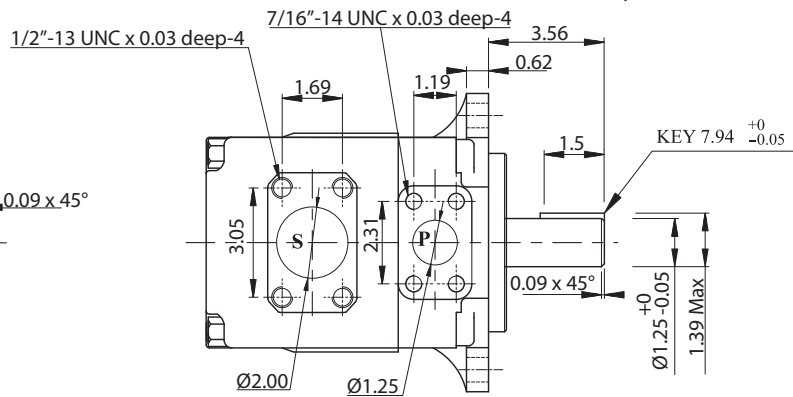

Shaft Code 2
(Keyed no SAE) (SAE C spec short)

Shaft torque limits in ³ /rev x PSI (cm ³ /rev x Bar)		
Pump	Shaft	Vp x p max
PT6DS	1	38299 (43283)
	2	30638 (34590)
	3	54207 (61200)
	4	54207 (61200)

PT6DS/PT6DSM OPERATING CHARACTERISTICS - TYPICAL 115 SUS (24 cst)

Series	Volumetric Displacement in ³ /rev (cm ³ /rev)	Speed n[RPM]	Flow Q in GPM (l/min)			Input Power HP (KW)			P. Max PSI (Bar)	MAX RPM
			p = 0 PSI (0 Bar)	p = 2000 PSI (140 Bar)	p = 3500 PSI (240 Bar)	p = 100 PSI (7 Bar)	p = 2000 PSI (140 Bar)	p = 3500 PSI (240 Bar)		
B/014	2.90 (47.6)	1000	12.57 (47.6)	10.12 (38.3)	8.48 (32.1)	2.01 (1.5)	16.76 (12.5)	27.76 (20.70)	3500 (240)	2500
		1500	18.86 (71.4)	16.41 (62.1)	14.77 (55.9)	3.08 (2.3)	24.81 (18.5)	41.04 (30.60)		
B/017	3.55 (58.2)	1000	15.37 (58.2)	13.74 (52.0)	12.63 (47.8)	2.15 (1.6)	19.85 (14.8)	32.99 (24.60)		
		1500	23.06 (87.3)	20.61 (78.0)	18.97 (71.8)	3.35 (2.5)	29.77 (22.2)	49.62 (37.00)		
B/020	4.03 (66.0)	1000	17.44 (66.0)	14.98 (56.7)	13.34 (50.5)	2.28 (1.7)	22.53 (16.8)	37.55 (28.00)		
		1500	26.15 (99.0)	23.70 (89.7)	22.06 (83.5)	3.75 (2.8)	33.39 (24.9)	55.92 (41.70)		
B/024	4.85 (79.5)	1000	21.00 (79.5)	18.54 (70.2)	16.91 (64.0)	2.55 (1.9)	26.69 (19.9)	44.79 (33.40)		
		1500	31.52 (119.3)	29.06 (110.0)	27.42 (103.8)	4.02 (3.0)	39.69 (29.6)	66.78 (49.80)		
B/028	5.47 (89.7)	1000	23.70 (89.7)	21.24 (80.4)	19.60 (74.2)	2.68 (2.0)	29.90 (22.3)	50.29 (37.50)		
		1500	35.53 (134.5)	33.07 (125.2)	31.44 (119.0)	4.29 (3.2)	44.52 (33.2)	74.96 (55.90)		
B/031	6.00 (98.3)	1000	25.97 (98.3)	23.51 (89.0)	21.87 (82.8)	2.82 (2.1)	32.59 (24.3)	54.85 (40.90)		
		1500	38.97 (147.5)	36.48 (138.1)	34.84 (131.9)	4.43 (3.3)	48.54 (36.2)	81.80 (61.00)		
B/035	6.77 (111.0)	1000	29.32 (111.0)	26.87 (101.7)	25.23 (95.5)	3.08 (2.3)	36.61 (27.3)	61.69 (46.00)		
		1500	43.98 (166.5)	41.53 (157.2)	39.89 (151.0)	4.69 (3.5)	54.58 (40.7)	92.13 (68.70)		
B/038	7.34 (120.3)	1000	31.78 (120.3)	29.32 (111.0)	27.69 (104.8)	3.22 (2.4)	39.43 (29.4)	66.78 (49.80)		
		1500	47.66 (180.4)	45.20 (171.1)	43.56 (164.9)	4.96 (3.7)	58.87 (43.9)	99.64 (74.30)		
B/042 ⁽¹⁾	8.30 (136.0)	1000	35.93 (136.0)	33.47 (126.7)	31.83 (120.5)	3.49 (2.6)	44.39 (33.1)	75.10 (56.00)		
		1500	53.89 (204.0)	51.43 (194.7)	49.80 (188.5)	5.36 (4.0)	66.25 (49.4)	112.24 (83.70)		
B/045 ⁽¹⁾	8.89 (145.7)	1000	38.49 (145.7)	36.03 (136.4)	34.40 (130.2)	3.62 (2.7)	47.34 (35.3)	80.33 (59.90)		
		1500	57.72 (218.5)	55.26 (209.2)	53.63 (203.0)	5.50 (4.1)	70.81 (52.8)	120.02 (89.50)		
B/050 ⁽¹⁾	9.64 (158.0)	1000	41.74 (158.0)	39.28 (148.7)	38.30 (145.0 (2))	3.75 (2.8)	51.23 (38.2)	76.17 (56.80 (2))	3062 (210)	2200
		1500	62.61 (237.0)	60.15 (227.7)	59.17 (224.0 (2))	5.90 (4.4)	76.44 (57.0)	113.99 (85.00 (2))		

(1) B/042 - B/045 - B/050 = 2200 RPM max.

(2) B/050 = 3062 PSI max. int.

Min Speed : 600 RPM

PT6E * - **066-1** **R** **00** - **A** **1** *

① ② ③ ④ ⑤ ⑥ ⑦ ⑧ ⑨

- ① **Series** PT6E - SAE-C 2-Bolt Mount
- ② **Y-Metric port connection (not for code Q)**
Omit for UNC
- ③ **Cam Ring**
Volumetric displacement in³/ rev (cm³/rev)

042 = 8.07 (132.3)	062 = 12.00 (196.7)
045 = 8.69 (142.4)	066 = 13.02 (213.3)
050 = 9.67 (158.5)	072 = 13.86 (227.1)
052 = 10.06 (164.8)	085 = 16.46 (269.8)
- ④ **Type of Shaft**
 1 = Keyed (SAE CC)
 2 = Keyed (No SAE)
 3 = Splined (SAE C)
 4 = Splined (SAE CC)
- ⑤ **Rotation**
(viewed from shaft end)
R= clockwise
L= counter-clockwise

- ⑥ **Porting Combination**
00=Standard
- ⑦ **Design Letter**
- ⑧ **Seal Class**
 1= S1 HNBR (for mineral oil)
 4= S4 EPDM (for fire resistant fluids)
 5= S5 Viton (for mineral oil and fire resistant fluids)
- ⑨ **Modifications**

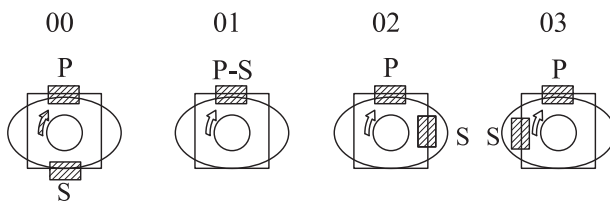

S = Suction port P = Pressure port

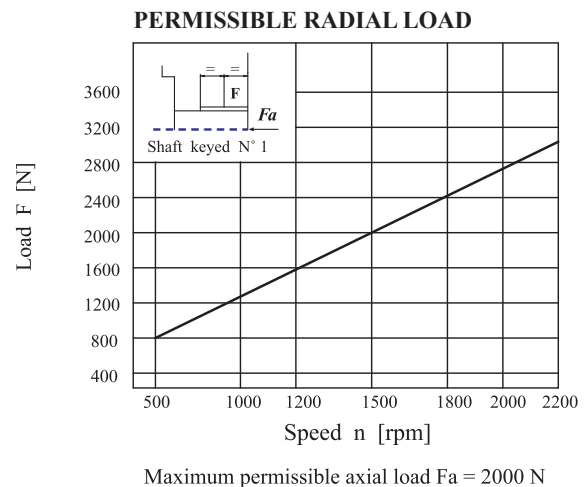
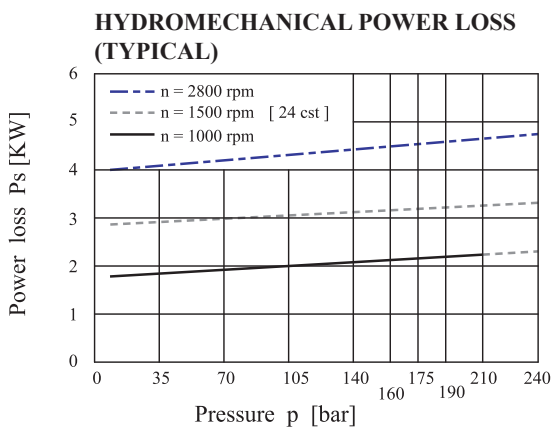
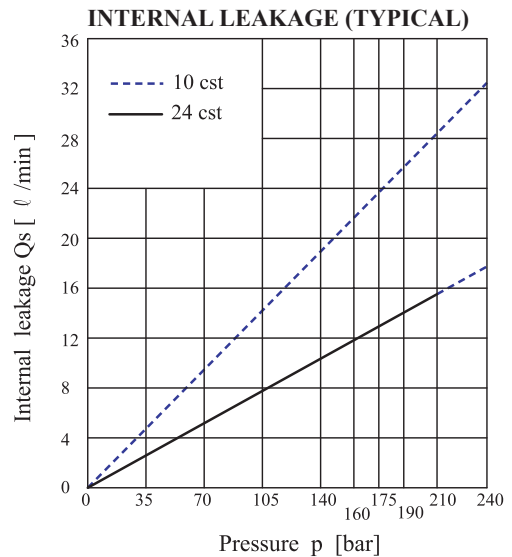



PT6E Dimensional Drawing

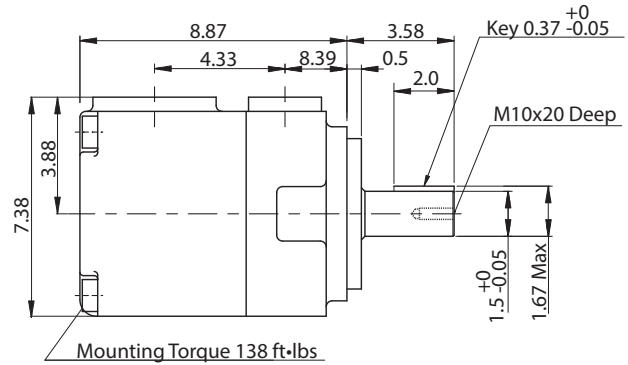
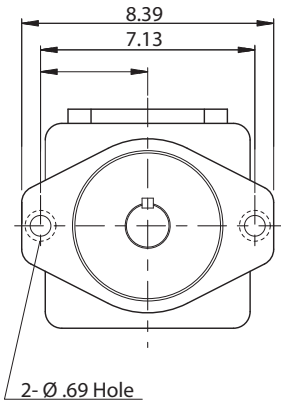

Shaft Code 1
(Keyed SAE CC)

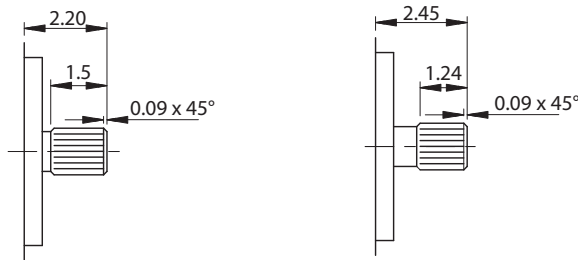

Shaft Code 3
SAE C Splined shaft
12/24 dp. -14 teeth
30° pressure angle
Flat root side fit

Shaft Code 4
SAE CC Splined shaft
12/24 dp. -17 teeth
30° pressure angle
Flat root side fit

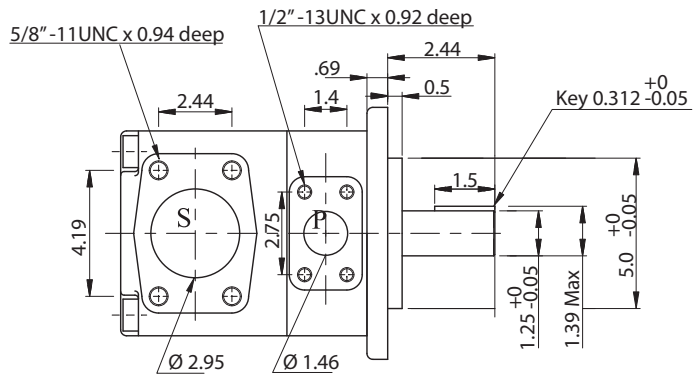

Shaft Code 2
(Keyed no SAE)

Shaft torque limits in ³ /rev x PSI (cm ³ /rev x Bar)		
Pump	Shaft	V _p x p max
PT6E	1	48273 (54555)
	2	30638 (34590)
	3	54207 (61200)
	4	54207 (61200)
	T	62356 (70400)

PT6E OPERATING CHARACTERISTICS - TYPICAL 115 SUS (24 cSt)

Series	Volumetric Displacement in ³ /rev (cm ³ /rev)	Speed n[RPM]	Flow Q in GPM (l/min)			Input Power HP (KW)			P. Max PSI (Bar)	MAX RPM
			p = 0 PSI (0 Bar)	p = 2000 PSI (140 Bar)	p = 3500 PSI (240 Bar)	p = 100 PSI (7 Bar)	p = 2000 PSI (140 Bar)	p = 3500 PSI (240 Bar)		
042	8.07 (132.3)	1000	34.95 (132.3)	32.31 (122.3)	30.43 (115.2)	4.29 (3.2)	44.12 (32.9)	74.02 (55.2)	3500 (240)	2200
		1500	52.44 (198.5)	49.80 (188.5)	47.89 (181.3)	6.97 (5.2)	66.25 (49.4)	110.77 (82.6)		
045	8.69 (142.4)	1000	37.62 (142.4)	34.98 (132.4)	33.10 (125.3)	4.56 (3.4)	47.34 (35.3)	79.39 (59.2)		
		1500	56.43 (213.6)	53.79 (203.6)	51.91 (196.5)	7.24 (5.4)	70.94 (52.9)	118.95 (88.7)		
050	9.67 (158.5)	1000	41.87 (158.5)	39.23 (148.5)	37.35 (141.4)	4.69 (3.5)	52.30 (39.0)	87.97 (65.6)		
		1500	62.79 (237.7)	60.15 (227.7)	58.28 (220.6)	7.64 (5.7)	78.45 (58.5)	131.82 (98.3)		
052	10.06 (164.8)	1000	43.54 (164.8)	40.89 (154.8)	39.02 (147.7)	4.83 (3.6)	54.31 (40.5)	91.46 (68.2)		
		1500	65.30 (247.2)	62.66 (237.2)	60.79 (230.1)	7.78 (5.8)	81.53 (60.8)	136.92 (102.1)		
062	12.00 (196.7)	1000	51.96 (196.7)	49.32 (186.7)	47.45 (179.6)	5.36 (4.0)	64.23 (47.9)	108.49 (80.9)		
		1500	77.93 (295.0)	75.29 (285.0)	73.41 (277.9)	8.58 (6.4)	96.42 (71.9)	162.67 (121.3)		
066	13.02 (213.3)	1000	56.35 (213.3)	53.71 (203.3)	51.83 (196.2)	5.63 (4.2)	69.46 (51.8)	117.47 (87.6)		
		1500	84.51 (319.9)	81.87 (309.9)	79.99 (302.8)	8.98 (6.7)	104.20 (77.7)	175.94 (131.2)		
072	13.86 (227.1)	1000	59.99 (227.1)	57.35 (217.1)	55.48 (210.0)	5.77 (4.3)	73.76 (55.0)	124.85 (93.1)		
		1500	89.98 (340.6)	87.34 (330.6)	85.46 (323.5)	9.25 (6.9)	110.77 (82.6)	187.07 (139.5)		
085 ₍₁₎	16.46 (269.8)	1000	71.27 (269.8 (2)	70.03 (265.1)	()	6.44 (4.8 (2)	58.33 (43.5 (2)	()	1450 (100)	2000
		1500	106.91 (404.7 (2)	105.06 (397.7)	()	9.79 (7.3 (2)	87.57 (65.3 (2)	()	()	()

(1) 085 = 2000 RPM max.

(2) 085 = 1087 PSI cont. 085 = 1305 PSI max. int.

Min Speed : 600 RPM

PT6EM ^{*} - **066-3** **R** **00** - **B** **1** ^{*}

① ② ③ ④ ⑤ ⑥ ⑦ ⑧ ⑨

① **Series** PT6EM - SAE-C 2-Bolt Mount

② **Y-Metric port connection**
Omit for UNC

③ **Cam Ring**
Volumetric displacement in³/rev (cm³/rev)

042 = 8.07 (132.3)	062 = 12.00 (196.7)
045 = 8.69 (142.4)	066 = 13.02 (213.3)
050 = 9.67 (158.5)	072 = 13.86 (227.1)
052 = 10.06 (164.8)	085 = 16.46 (269.8)

④ **Type of Shaft**

- 1 = Keyed (SAE CC)
- 2 = Keyed (No SAE)
- 3 = Splined (SAE C)
- 4 = Splined (SAE CC)

⑤ **Rotation**
(viewed from shaft end)

R= clockwise
L= counter-clockwise

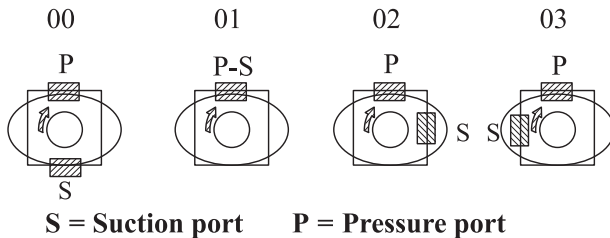

Do not operate pump more than 5 seconds at any speed or viscosity if internal leakage is more than 50% of theoretical flow.

⑥ **Porting Combination**
00=Standard

⑦ **Design Letter**

⑧ **Seal Class**

- 1= S1 HNBR (for mineral oil)
- 4= S4 EPDM (for fire resistant fluids)
- 5= S5 Viton (for mineral oil and fire resistant fluids)

⑨ **Modifications**

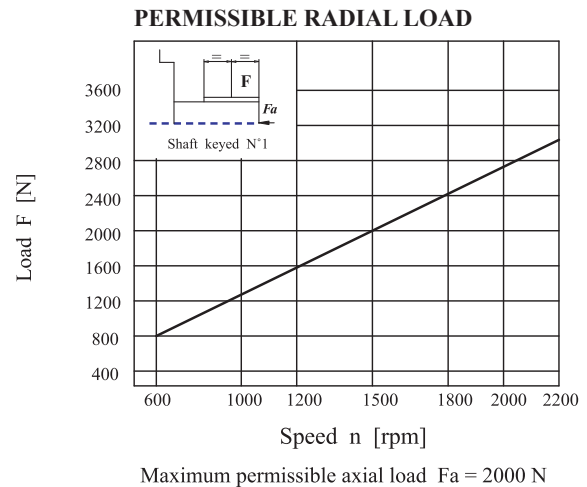
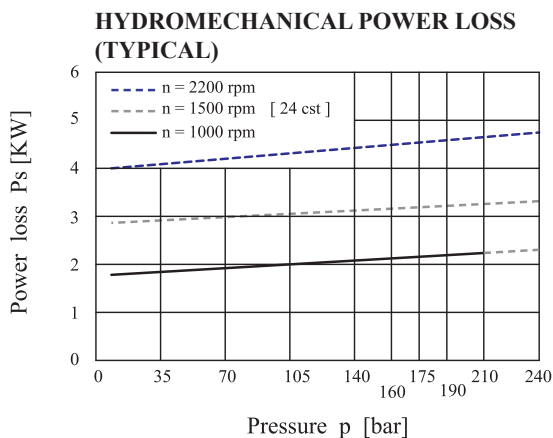
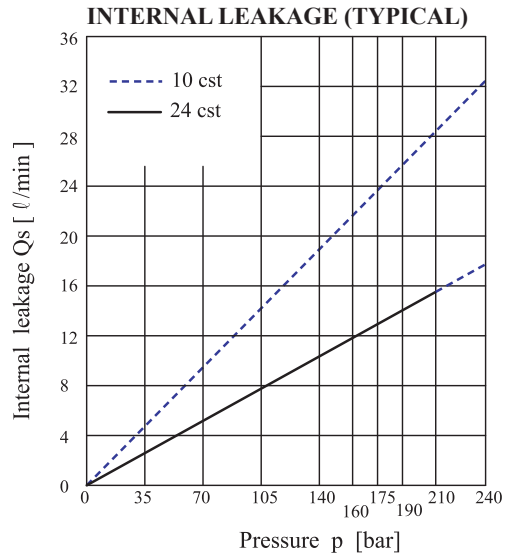



PT6EM Dimensional Drawing

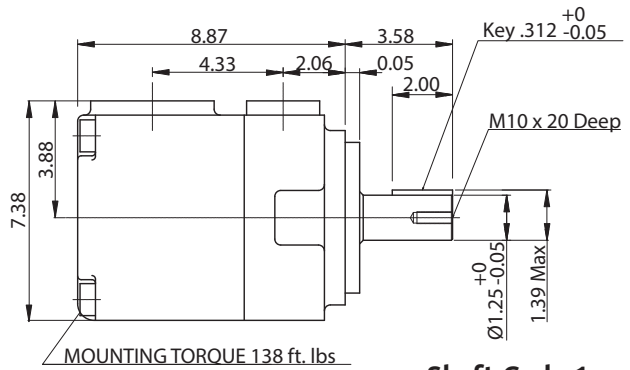
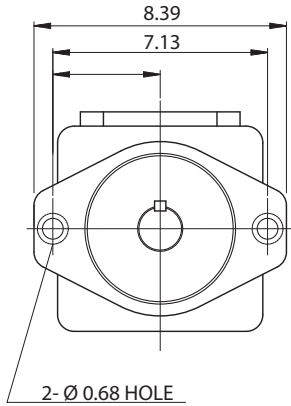

Shaft Code 1
(Keyed SAE CC)

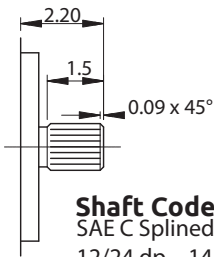

Shaft Code 3
SAE C Splined Shaft
12/24 dp. - 14 teeth
30° pressure angle
Flat root side fit

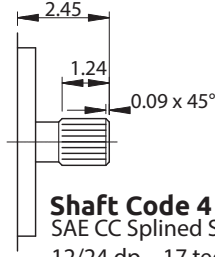

Shaft Code 4
SAE CC Splined Shaft
12/24 dp. - 17 teeth
30° pressure angle
Flat root side fit

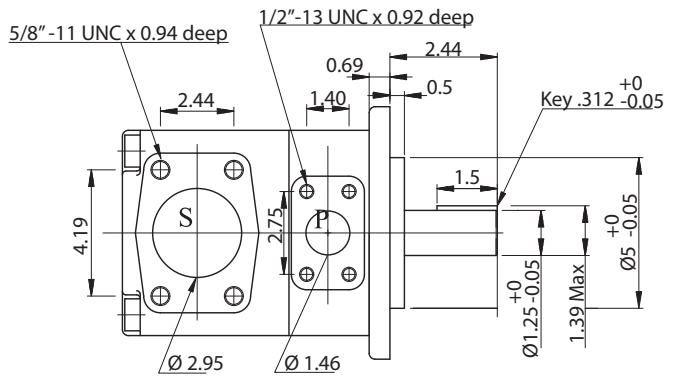

Shaft Code 2
(Keyed no SAE)

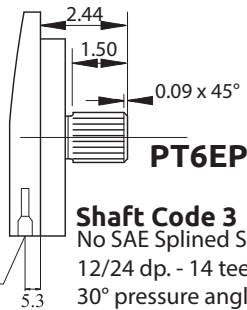

Shaft Code 3
No SAE Splined Shaft
12/24 dp. - 14 teeth
30° pressure angle
Flat root side fit
(SAE C Spec)

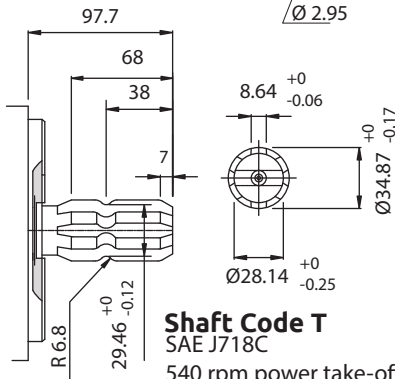

Shaft Code T
SAE J718C
540 rpm power take-off
For Farm Tractor Application

Drain hole between double shaft seals

Shaft torque limits in ³ /rev x psi (cm ³ /rev x bar)		
Pump	Shaft	Vp x p max
PT6EM	1	38299 (43283)
	2	30638 (34590)
	3	54207 (61200)
	4	54207 (61200)
	T	62356 (70400)

PT6EM OPERATING CHARACTERISTICS - TYPICAL 115 SUS (24 cSt)

Series	Volumetric Displacement in ³ /rev (cm ³ /rev)	Speed n[RPM]	Flow Q in GPM (l/min)			Input Power HP (KW)			P. Max PSI (Bar)	MAX RPM
			p = 0 PSI (0 Bar)	p = 2000 PSI (140 Bar)	p = 3500 PSI (240 Bar)	p = 100 PSI (7 Bar)	p = 2000 PSI (140 Bar)	p = 3500 PSI (240 Bar)		
042	8.07 (132.3)	1000	34.95 (132.3)	32.31 (122.3)	30.43 (115.2)	4.29 (3.2)	44.12 (32.9)	74.02 (55.2)	3500 (240)	2200
		1500	52.44 (198.5)	49.80 (188.5)	47.89 (181.3)	6.97 (5.2)	66.25 (49.4)	110.77 (82.6)		
045	8.69 (142.4)	1000	37.62 (142.4)	34.98 (132.4)	33.10 (125.3)	4.56 (3.4)	47.34 (35.3)	79.39 (59.2)		
		1500	56.43 (213.6)	53.79 (203.6)	51.91 (196.5)	7.24 (5.4)	70.94 (52.9)	118.95 (88.7)		
050	9.67 (158.5)	1000	41.87 (158.5)	39.23 (148.5)	37.35 (141.4)	4.69 (3.5)	52.30 (39.0)	87.97 (65.6)		
		1500	62.79 (237.7)	60.15 (227.7)	58.28 (220.6)	7.64 (5.7)	78.45 (58.5)	131.82 (98.3)		
052	10.06 (164.8)	1000	43.54 (164.8)	40.89 (154.8)	39.02 (147.7)	4.83 (3.6)	54.31 (40.5)	91.46 (68.2)		
		1500	65.30 (247.2)	62.66 (237.2)	60.79 (230.1)	7.78 (5.8)	81.53 (60.8)	136.92 (102.1)		
062	12.00 (196.7)	1000	51.96 (196.7)	49.32 (186.7)	47.45 (179.6)	5.36 (4.0)	64.23 (47.9)	108.49 (80.9)		
		1500	77.93 (295.0)	75.29 (285.0)	73.41 (277.9)	8.58 (6.4)	96.42 (71.9)	162.67 (121.3)		
066	13.02 (213.3)	1000	56.35 (213.3)	53.71 (203.3)	51.83 (196.2)	5.63 (4.2)	69.46 (51.8)	117.47 (87.6)		
		1500	84.51 (319.9)	81.87 (309.9)	79.99 (302.8)	8.98 (6.7)	104.20 (77.7)	175.94 (131.2)		
072	13.86 (227.1)	1000	59.99 (227.1)	57.35 (217.1)	55.48 (210.0)	5.77 (4.3)	73.76 (55.0)	124.85 (93.1)		
		1500	89.98 (340.6)	87.34 (330.6)	85.46 (323.5)	9.25 (6.9)	110.77 (82.6)	187.07 (139.5)		
085 ₍₁₎	16.46 (269.8)	1000	71.27 (269.8 (2)	70.03 (265.1)	()	6.44 (4.8 (2)	58.33 (43.5 (2)	()	1450 (100)	2000
		1500	106.91 (404.7 (2)	105.06 (397.7)	()	9.79 (7.3 (2)	87.57 (65.3 (2)	()		

(1) 085 = 2000 RPM max

(2) 085 = 1087 PSI cont. 085 = 1305 PSI max. int

Min Speed : 600 RPM

PT6GC - B22 -6 R 00 - A 1 - 00 *

① ② ③ ④ ⑤ ⑥ ⑦ ⑧ ⑨

① **Series** PT6GC - R. 17-102 Mount

② **Cam Ring**
Volumetric displacement in³/ rev (cm³/rev)

B03 = 0.66 (10.8)	B17 = 3.56 (58.3)
B05 = 1.05 (17.2)	B20 = 3.89 (63.8)
B06 = 1.30 (21.3)	B22 = 4.29 (70.3)
B08 = 1.61 (26.4)	B25 = 4.84 (79.3)
B10 = 2.08 (34.1)	B28 = 5.42 (88.8)
B12 = 2.26 (37.1)	B31 = 6.10 (100.0)
B14 = 2.81 (46.0)	

③ **Type of Shaft**

6 = Splined (DIN 5462)

④ **Rotation**

(viewed from shaft end)

R = clockwise

L = counter-clockwise

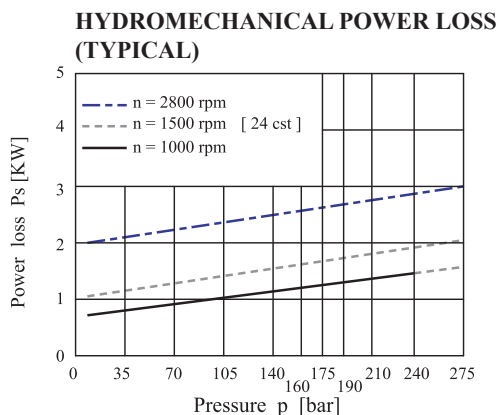
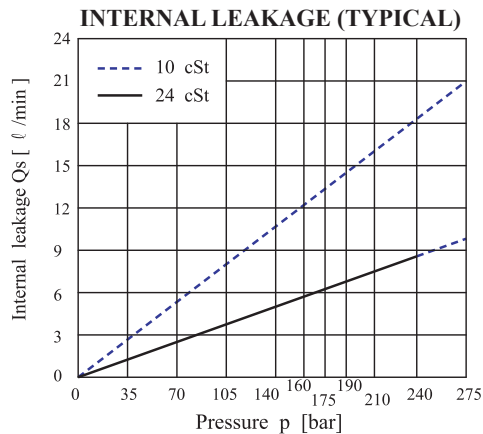

⑤ **Porting Combination**
00=Standard

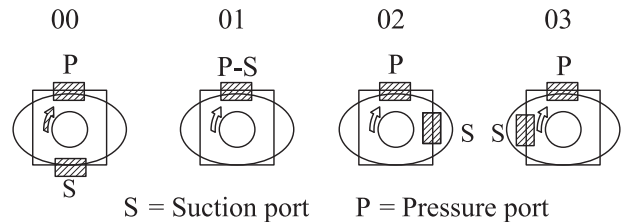

⑥ **Design Letter**

⑦ **Seal Class**

1 = S1 HNBR (for mineral oil)

4 = S4 EPDM (for fire resistant fluids)

5 = S5 Viton (for mineral oil and fire resistant fluids)

⑧ **Mounting W/connection variables**

00 = Flange 1" BSPP

01 = Flange 1" SAE 4 bolts (UNC)

M1 = Flange 1" SAE 4 bolts (Metric)

⑨ **Modifications**

Do not operate pump more than 5 seconds at any speed or viscosity if internal leakage is more than 50% of theoretical flow.

Total leakage is the sum of each section loss at its operating conditions

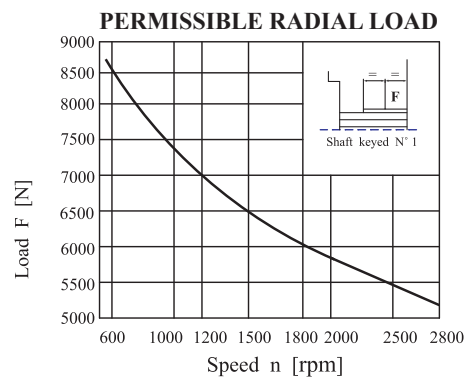

Life time 3000 hours when 70% of the time at 500 N and 30% at max. load



PT6GC Dimensional Drawing

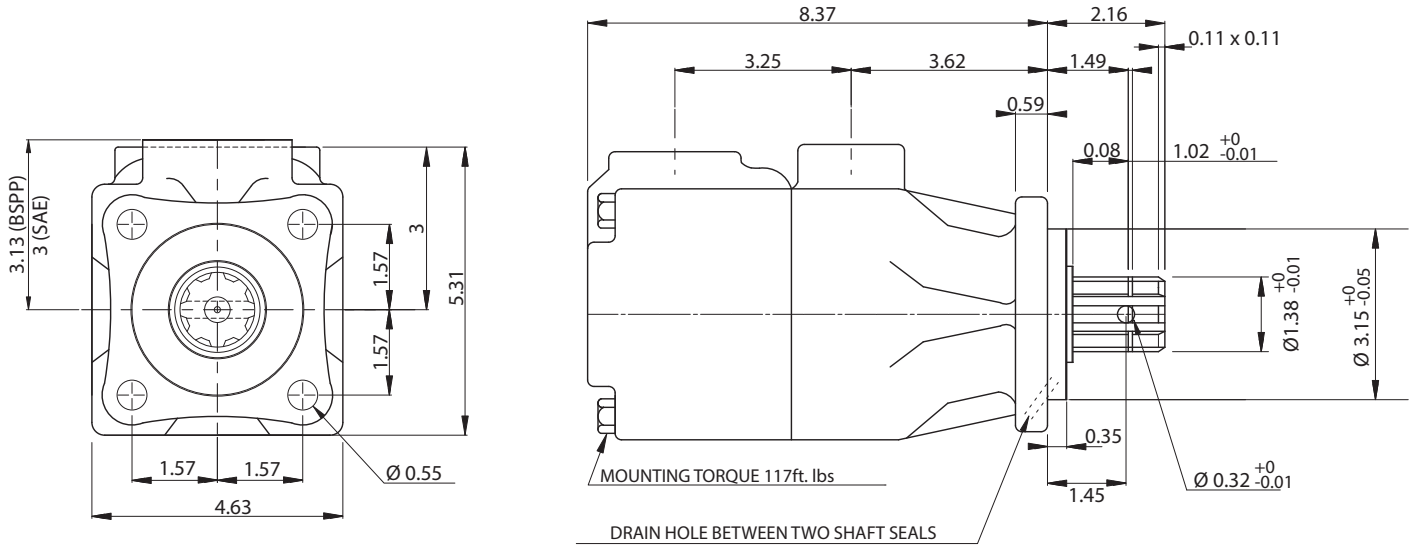

Shaft Code 6
(DIN 5462) B8 x 32 x 36

CODE 00

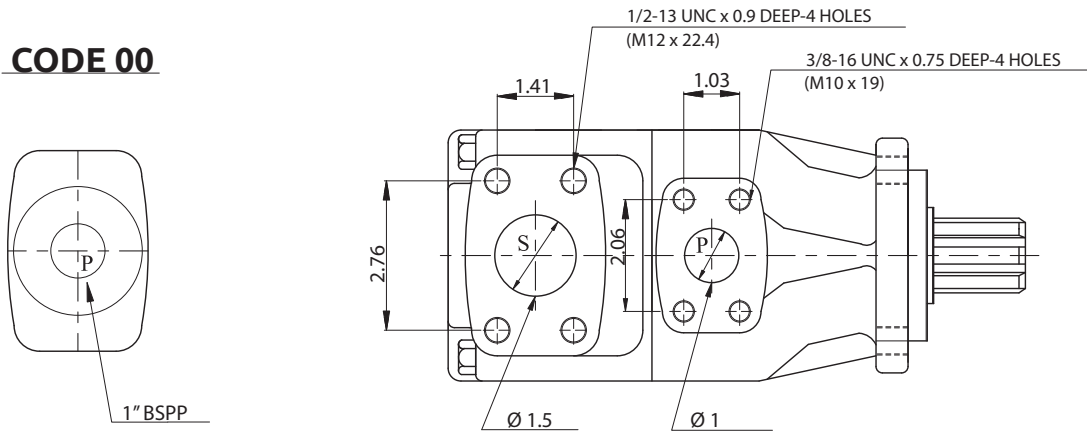

PT6GC OPERATING CHARACTERISTICS - TYPICAL 115 SUS (24 cSt)

Series	Volumetric Displacement in ³ /rev (cm ³ /rev)	Flow Q in GPM (l/min) @ 1500 RPM			Input Power HP (KW) @ 1500 RPM			P. Max PSI (Bar)	MAX RPM
		p = 0 PSI (0 Bar)	p = 2000 PSI (140 Bar)	p = 3500 PSI (240 Bar)	p = 100 PSI (7 Bar)	p = 2000 PSI (140 Bar)	p = 3500 PSI (240 Bar)		
B03	0.66 (10.8)	4.28 (16.2)	2.83 (10.7)	()	1.74 (1.3)	7.11 (5.3)	()	4000 (275)	2800
B05	1.05 (17.2)	6.82 (25.8)	5.36 (20.3)	4.17 (15.8)	1.88 (1.4)	10.06 (7.5)	16.36 (12.2)		
B06	1.30 (21.3)	8.43 (31.9)	7.00 (26.5)	5.81 (22.0)	2.01 (1.5)	11.94 (8.9)	19.71 (14.7)		
B08	1.61 (26.4)	10.46 (39.6)	9.01 (34.1)	7.82 (29.6)	2.15 (1.6)	14.35 (10.7)	23.74 (17.7)		
B10	2.08 (34.1)	13.50 (51.1)	12.07 (45.7)	10.88 (41.2)	2.28 (1.7)	17.97 (13.4)	29.90 (22.3)		
B12	2.26 (37.1)	14.69 (55.6)	13.26 (50.2)	12.07 (45.7)	2.28 (1.7)	19.31 (14.4)	32.32 (24.1)		
B14	2.81 (46.0)	18.23 (69.0)	16.77 (63.5)	15.59 (59.0)	2.55 (1.9)	23.60 (17.6)	39.56 (29.5)		
B17	3.56 (58.3)	23.09 (87.4)	21.66 (82.0)	20.47 (77.5)	2.82 (2.1)	29.37 (21.9)	49.48 (36.9)		
B20	3.89 (63.8)	25.28 (95.7)	23.83 (90.2)	22.64 (85.7)	2.95 (2.2)	31.92 (23.8)	53.91 (40.2)		
B22	4.29 (70.3)	27.84 (105.4)	26.42 (100.0)	25.23 (95.5)	3.08 (2.3)	35.00 (26.1)	59.14 (44.1)		
B25 ₍₁₎	4.84 (79.3)	31.41 (118.9)	29.98 (113.5)	28.79 (109.0)	3.35 (2.5)	39.16 (29.2)	66.38 (49.5)	3062 (210)	2500
B28 ₍₁₎	5.42 (88.8)	35.19 (133.2)	33.73 (127.7)	32.89 (124.5 (2)	3.75 (2.8)	43.85 (32.7)	65.04 (48.5 (2)		
B31 ₍₁₎	6.10 (100.0)	39.63 (150.0)	38.17 (144.5)	37.33 (141.3 (2)	3.75 (2.8)	48.95 (36.5)	72.95 (54.4 (2)		

(1) B25 = 2500 RPM max.

(2) B28- B31 = 3062 PSI max. int.
-- Do not use because internal leakage great than 50% theoretical flow.

Min Speed : 400 RPM

PT7B/PT7BS - B10 -1 R 00 - A 1 - M0 *

① ② ③ ④ ⑤ ⑥ ⑦ ⑧ ⑨

① Series

PT7B - ISO 100 A2 HW 2 Bolt Mount
3019-2 Flange
PT7BS - SAE-B 2-Bolt Mount
J744 Flange

② Cam Ring

Volumetric displacement in³/ rev (cm³/rev)

B02 = 0.35 (5.7) B09 = 1.71 (28.0)
B03 = 0.60 (9.8) B10 = 1.94 (31.8)
B04 = 0.78 (12.8) B11 = 2.13 (34.9)
B05 = 0.97 (15.9) B12 = 2.50 (40.9)
B06 = 1.21 (19.8) B14 = 2.75 (45.1)
B07 = 1.37 (22.5) B15 = 3.05 (50.0)
B08 = 1.52 (24.9)

③ Type of Shaft PT7B-PT7BS

2 = Keyed (ISO R775)

Type of Shaft PT7BS

1 = Keyed (SAE B)
3 = Splined (SAE B)
4 = Splined (SAE BB)

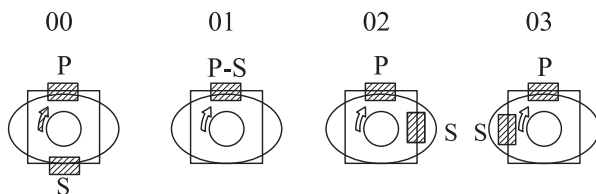

S = Suction port P = Pressure port

④ Rotation

(viewed from shaft end)
R= clockwise
L= counter-clockwise

⑤ Porting Combination

00=Standard

⑥ Design Letter

⑦ Seal Class

1= S1 HNBR (for mineral oil)
4= S4 EPDM (for fire resistant fluids)
5= S5 Viton (for mineral oil and fire resistant fluids)

⑧ Mounting W/connection variables

4 bolts SAE flange (J518C)

	Unc		Metric	
	PT7BS		PT7B-PT7BS	
	00	01	M0	M1
P	1"	3/4"	1"	3/4"
S	1 1/2"			

⑨ Modifications

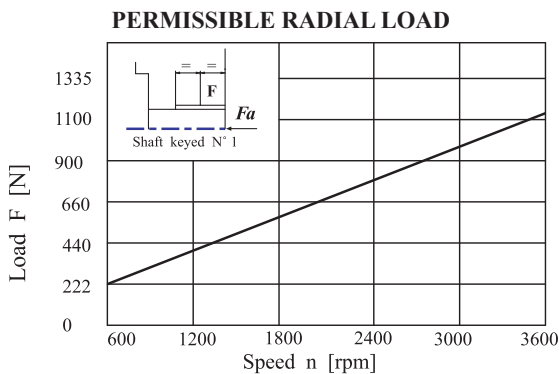
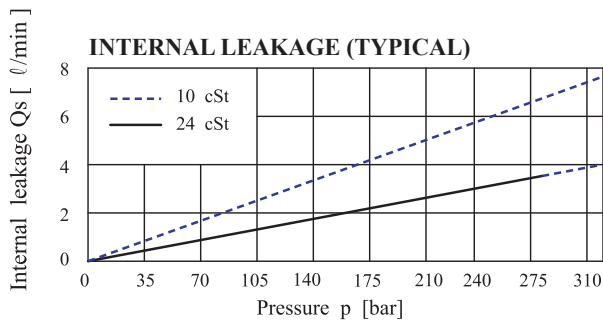

Maximum permissible axial load Fa = 800 N

HYDROMECHANICAL POWER LOSS (TYPICAL)

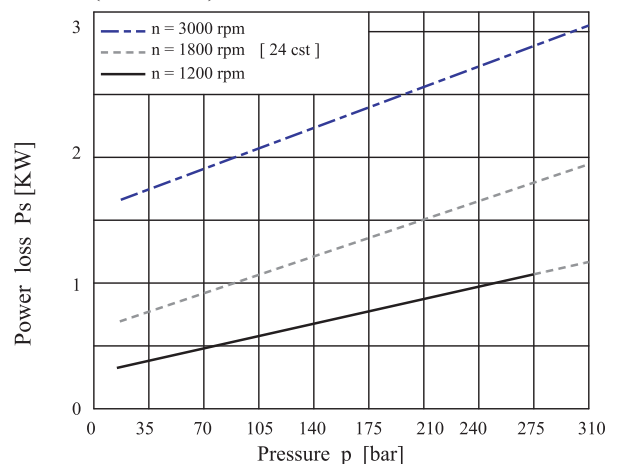



PT7B Dimensional Drawing

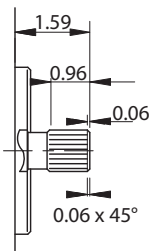
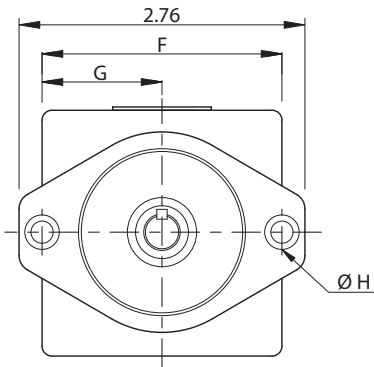

Shaft Code 3
SAE B Splined Shaft
16/32 dp. - 13 teeth
30° pressure angle
Flat root side fit

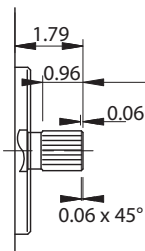

Shaft Code 4
SAE BB Splined Shaft
16/32 dp. - 15 teeth
30° pressure angle
Flat root side fit

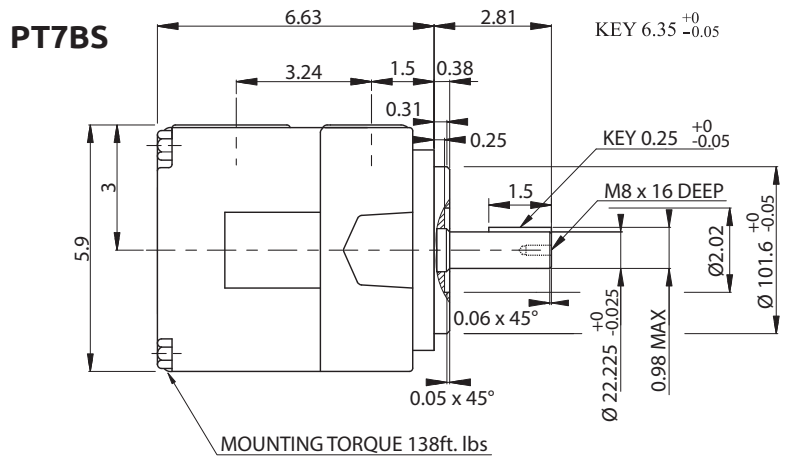

Shaft Code 1
(KEYED SAE B)

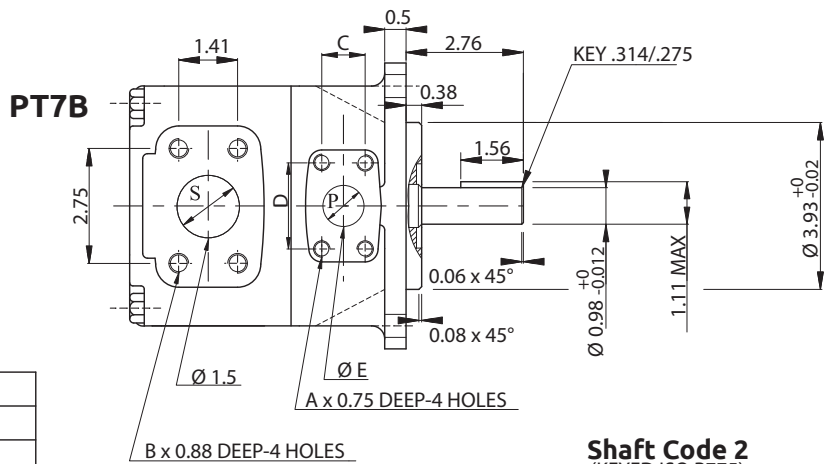

Shaft Code 2
(KEYED ISO R775)

	PT7BS		PT7B	
	00	01	M0	M1
A	3/8-16 UNC		M10	
B	1/2-13 UNC		M12	
C	1.03 (26.2)	0.874 (22.2)	1.03 (26.2)	0.874 (22.2)
D	2.06 (52.4)	1.874 (47.6)	2.06 (52.4)	1.874 (47.6)
Ø E	1.00 (25.4)	0.75 (19.05)	1.00 (25.4)	0.75 (19.05)
F	5.75 (146.0)		5.51 (140.0)	
G	2.87 (73.0)		2.75 (70.0)	
Ø H	0.56 (14.3)		0.55 (14.0)	

Shaft torque limits in ³ /rev x PSI (cm ³ /rev x Bar)		
Pump	Shaft	Vp x p max
PT7B	1	14615 (16516)
	2	18246 (20620)
	3	18624 (20620)
	4	18624 (20620)

PT7B OPERATING CHARACTERISTICS - TYPICAL 115 SUS (24 cSt)

Series	Volumetric Displacement in ³ /rev (cm ³ /rev)	Flow Q in GPM (l/min) @ 1800 RPM			Input Power HP (KW) @ 1800 RPM			P. Max PSI (Bar)	MAX RPM
		p = 0 PSI (0 Bar)	p = 2000 PSI (140 Bar)	p = 4667 PSI (320 Bar)	p = 100 PSI (7 Bar)	p = 2000 PSI (140 Bar)	p = 3500 PSI (240 Bar)		
B02	0.35 (5.7)	2.75 (10.4)	2.32 (8.8)	1.72 (6.5)	0.74 (0.55)	4.01 (2.99)	8.58 (6.40)	4667 (320)	3600
B03	0.60 (9.8)	4.65 (17.6)	4.20 (15.9)	3.62 (13.7)	0.84 (0.63)	6.24 (4.65)	13.75 (10.25)		
B04	0.78 (12.8)	6.08 (23.0)	5.65 (21.4)	5.07 (19.2)	0.94 (0.70)	7.90 (5.89)	17.61 (13.13)		
B05	0.97 (15.9)	7.56 (28.6)	7.11 (26.9)	6.53 (24.7)	1.02 (0.76)	9.62 (7.17)	21.62 (16.12)		
B06	1.21 (19.8)	9.40 (35.6)	8.96 (33.9)	8.37 (31.7)	1.13 (0.84)	11.79 (8.79)	26.66 (19.88)		
B07	1.37 (22.5)	10.67 (40.4)	10.25 (38.8)	9.64 (36.5)	1.19 (0.89)	13.29 (9.91)	30.13 (22.47)		
B08	1.52 (24.9)	11.81 (44.7)	11.39 (43.1)	10.80 (40.9)	1.26 (0.94)	14.62 (10.90)	33.23 (24.78)		
B09	1.71 (28.0)	13.29 (50.3)	12.84 (48.6)	12.26 (46.4)	1.35 (1.01)	16.35 (12.19)	37.24 (27.77)		
B10	1.94 (31.8)	15.11 (57.2)	14.66 (55.5)	14.11 (53.4)	1.49 (1.11)	18.44 (13.75)	42.13 (31.42)		
B11	2.13 (34.9)	16.62 (62.9)	16.17 (61.2)	15.59 (59.0 (1)	1.54 (1.15)	20.17 (15.04)	43.21 (32.22 (1)		
B12	2.50 (40.9)	19.47 (73.7)	19.05 (72.1)	18.52 (70.1 (1)	1.72 (1.28)	23.55 (17.56)	50.57 (37.71 (1)		
B14	2.75 (45.1)	21.35 (80.8)	20.92 (79.2)	20.34 (77.0 (1)	1.82 (1.36)	25.79 (19.23)	55.48 (41.37 (1)		
B15	3.05 (50.0)	23.72 (89.8)	23.33 (88.3)	22.85 (86.5 (2)	1.97 (1.47)	28.54 (21.28)	57.34 (42.76 (2)	4080 (280)	

(1) B11-B12-B14 = 4375 PSI max. int

(2) B15 = 4080 PSI max. int.

Min Speed: 600 RPM

PT7D/PT7DS - B45 - 1 R 00 - A 1-M0 *

① ② ③ ④ ⑤ ⑥ ⑦ ⑧ ⑨

① Series

PT7D - ISO 125 A2 HW 2 Bolt Mount
3019-2 Flange
PT7DS - SAE-C 2-Bolt Mount
J744 Flange

② Cam Ring

Volumetric displacement in ³/rev (cm³/rev)

B14 = 2.68 (43.9) B35 = 6.92 (113.4)
B17 = 3.36 (55.0) B38 = 7.36 (120.6)
B20 = 4.03 (66.0) B42 = 8.39 (137.5)
B24 = 4.95 (81.1) B45 = 8.89 (145.7)
B28 = 5.49 (89.9) B50 = 9.64 (157.9)
B31 = 6.05 (99.1)

③ Type of Shaft

1 = Keyed (SAE C 32-1)
2 = Keyed (No SAE)
3 = Splined (SAE C 32-4)
4 = Splined (SAE C spec long)

Type of Shaft PT7D-PT7DS

5 = Keyed (ISO 3019-2-G32M)

④ Rotation

(viewed from shaft end)

R = clockwise
L = counter-clockwise

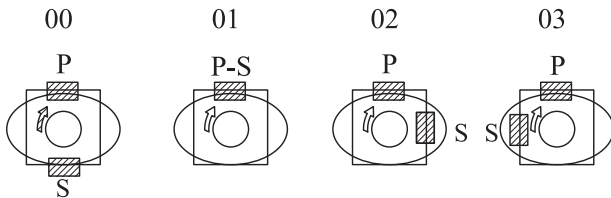

S = Suction port P = Pressure port

⑤ Porting Combination

00=Standard

⑥ Design Letter

⑦ Seal Class

1= S1 HNBR (for mineral oil)
4= S4 EPDM (for fire resistant fluids)
5= S5 Viton (for mineral oil and fire resistant fluids)

⑧ Mounting W/connection variables

P = 1" 1/4		S = 2"	
	UNC	METRIC	
PT7D		M0	
PT7DS	00	M0	Y0 1)

1) 250 bar max. int

⑨ Modifications

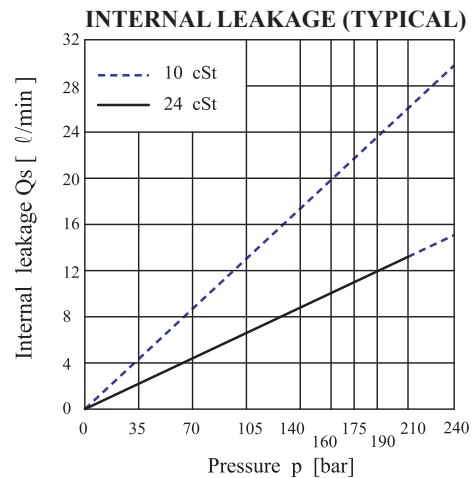

HYDROMECHANICAL POWER LOSS (TYPICAL)

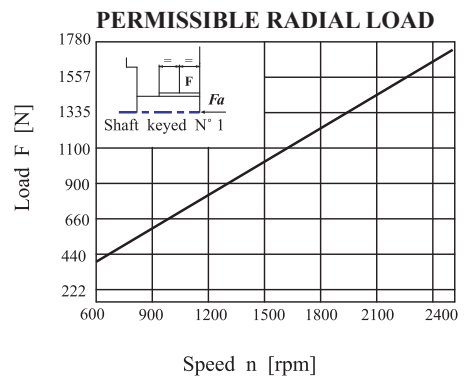
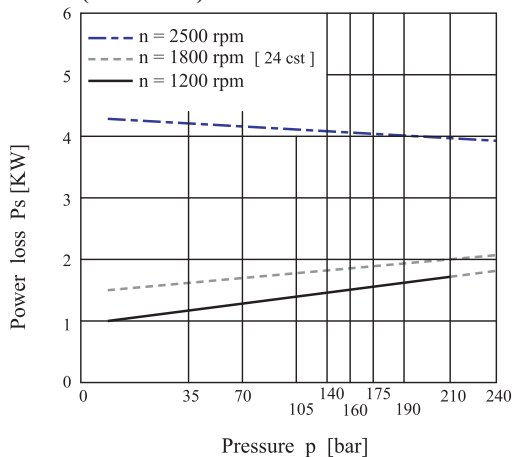

Maximum permissible axial load Fa = 1200 N



PT7D/PT7DS Dimensional Drawing

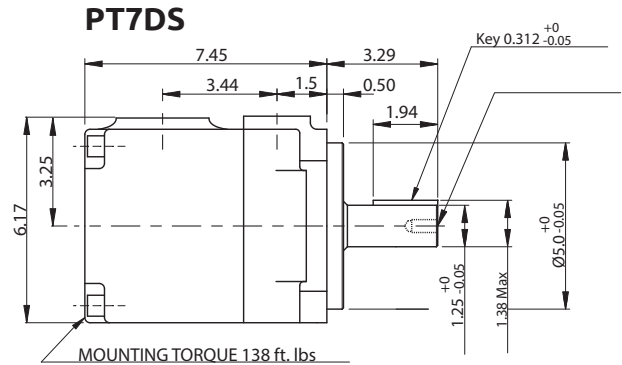
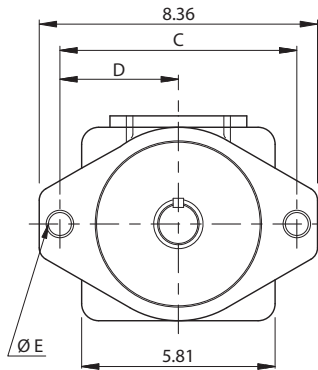

Shaft Code 1
(Keyed SAE C)

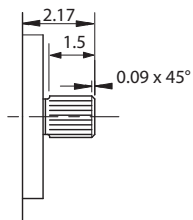

Shaft Code 3
SAE C Splined Shaft
12/24 dp, 14 teeth
30° pressure angle
Flat root side fit

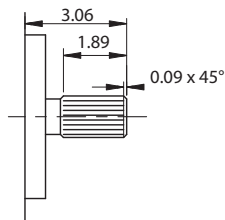

Shaft Code 4
SAE C spc(*) Splined Shaft
12/24 dp, 14 teeth
30° pressure angle
Flat root side fit.
(SAE C Spec Long)

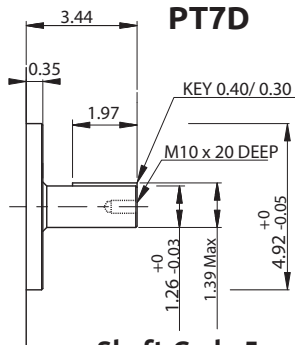

Shaft Code 5
(Keyed ISO R775)

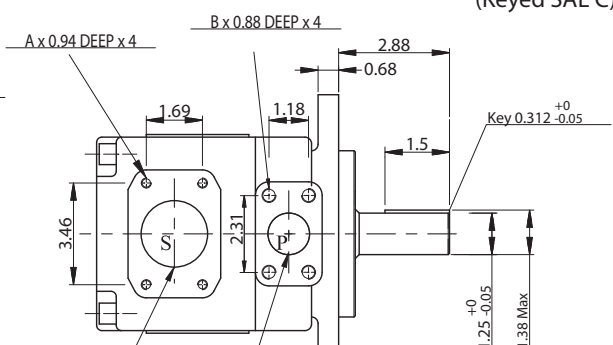

Shaft Code 2
(Keyed no SAE)

Shaft torque limits in ³ /rev x PSI (cm ³ /rev x Bar)		
Pump	Shaft	Vp x p max
PT7D PT7DS	1	38299 (43283)
	2	30638 (34590)
	3	54207 (61200)
	4	54207 (61200)
	5	39238 (44344)

	PT7DS		PT7D	
	00	M0	Y0 1)	M0
A	1/2 - 13 UNC	M12	M12	M12
B	7/16 - 14 UNC	M12	M10	M12
C	9.13		7.09	
D	3.56		3.54	
E	0.69		0.70	

1) 3626 psi max. int

PT7D OPERATING CHARACTERISTICS - TYPICAL 115 SUS (24 cSt)

Series	Volumetric Displacement Vp in ³ /rev (cm ³ /rev)	Flow Q in GPM (l/min) @ 1800 RPM			Input Power HP (KW) @ 1800 RPM			P. Max PSI (Bar)	MAX RPM
		p = 0 PSI (0 Bar)	p = 2000 PSI (140 Bar)	p = 4667 PSI (320 Bar)	p = 100 PSI (7 Bar)	p = 2000 PSI (140 Bar)	p = 3500 PSI (240 Bar)		
B14	2.68 (43.9)	20.90 (79.1)	19.15 (72.5)	17.14 (64.9)	3.49 (2.60)	27.76 (20.7)	58.47 (43.6)	4375 (300)	3000
B17	3.36 (55.0)	26.10 (98.8)	24.38 (92.3)	22.38 (84.7)	3.75 (2.80)	33.93 (25.3)	71.88 (53.6)		
B20	4.03 (66.0)	31.33 (118.6)	29.59 (112.0)	27.61 (104.5)	4.02 (3.00)	39.96 (29.8)	85.29 (63.6)		
B24	4.95 (81.1)	38.52 (145.8)	36.77 (139.2)	34.77 (131.6)	4.56 (3.40)	48.41 (36.1)	103.80 (77.4)		
B28	5.49 (89.9)	42.74 (161.8)	41.00 (155.2)	38.99 (147.6)	4.69 (3.50)	53.24 (39.7)	114.66 (85.5)		
B31	6.05 (99.1)	47.10 (178.3)	45.36 (171.7)	43.38 (164.2)	4.96 (3.70)	58.47 (43.6)	125.65 (93.7)		
B35	6.92 (113.4)	53.86 (203.9)	52.09 (197.2)	50.35 (190.6 (1)	0.00 (0.00)	66.25 (49.4)	130.35 (97.2 (1)	4083 (280)	3000
B38	7.36 (120.6)	57.27 (216.8)	55.53 (210.2)	53.79 (203.6 (1)	5.63 (4.20)	70.27 (52.4)	138.39 (103.2 (1)		
B42	8.39 (137.5)	65.30 (247.2)	63.56 (240.6)	62.05 (234.9 (2)	6.03 (4.50)	79.66 (59.4)	149.39 (111.4 (2)	3791 (260)	
B45	8.89 (145.7)	69.21 (262.0)	66.99 (253.6)	65.38 (247.5 (3)	6.71 (5.00)	83.68 (62.4)	144.43 (107.7 (3)	3500 (240)	
B50	9.64 (157.9)	75.02 (284.0)	72.86 (275.8)	71.67 (271.3 (4)	7.11 (5.30)	90.52 (67.5)	134.50 (100.3 (4)	3062 (210)	

(1) B35-B38 = 4083 PSI max. int. (2) B42 = 3791 PSI max. int.
(3) B45 = 3500 PSI max. int. (4) B50 = 3062 PSI max. int.

Min Speed : 600 RPM

PT7DSW - B45 - X R 00 - A 1-W0 *

① ② ③ ④ ⑤ ⑥ ⑦ ⑧ ⑨

① Series

② Cam Ring

Volumetric displacement in³/rev (cm³/rev)

B14 = 2.68 (43.9)	B35 = 6.92 (113.4)
B17 = 3.36 (55.0)	B38 = 7.36 (120.6)
B20 = 4.03 (66.0)	B42 = 8.39 (137.5)
B24 = 4.95 (81.1)	B45 = 8.89 (145.7)
B28 = 5.49 (89.9)	B50 = 9.64 (157.9)
B31 = 6.05 (99.1)	

③ Type of Shaft

2 = Keyed (No SAE)
 X = Keyed (No SAE)
 W = Keyed (No SAE)

④ Rotation

(viewed from shaft end)

R = clockwise
 L = counter-clockwise

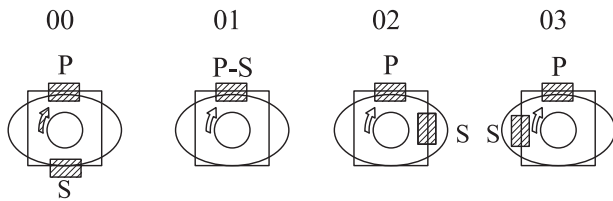

S = Suction port P = Pressure port

⑤ Porting Combination

00=Standard

⑥ Design Letter

⑦ Seal Class

1= S1 HNBR (for mineral oil)
 4= S4 EPDM (for fire resistant fluids)
 5= S5 Viton (for mineral oil and fire resistant fluids)

⑧ Mounting W/connection variables

PT7DSW	
UNC (W1)	
P= 1-1/4"	S= 2-1/2"

⑨ Modifications

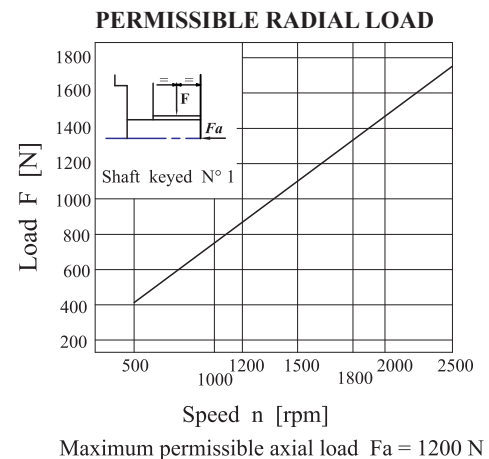
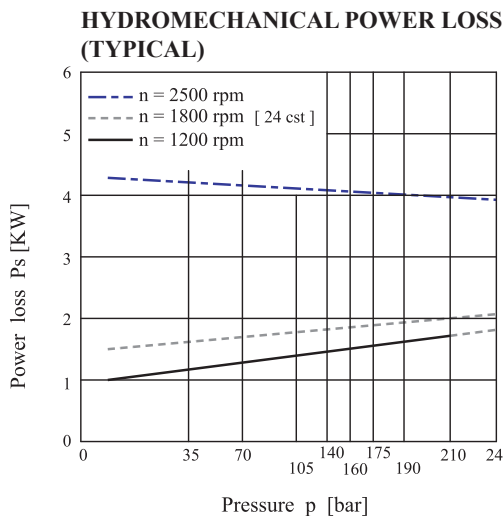
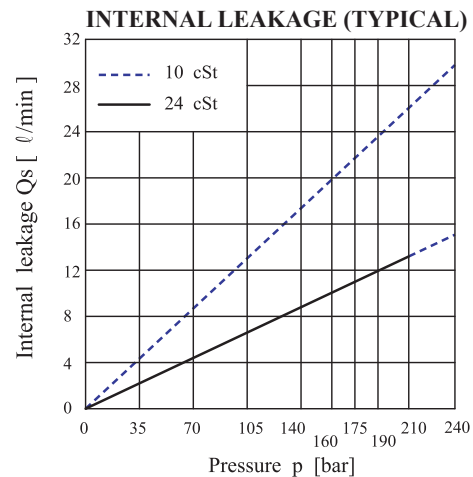



PT7DSW Dimensional Drawing

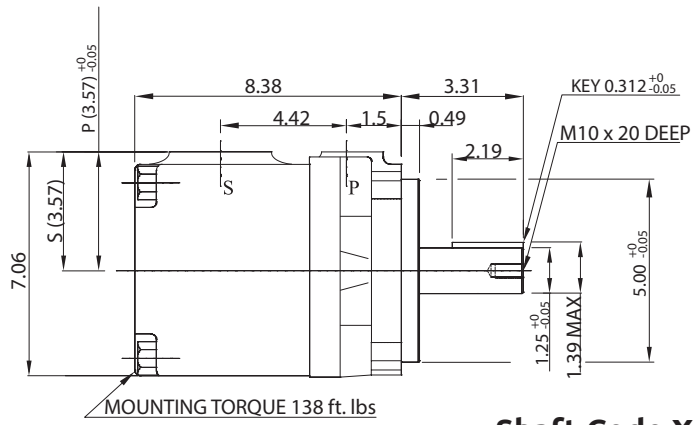
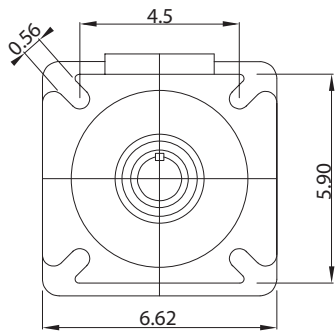

Shaft Code X

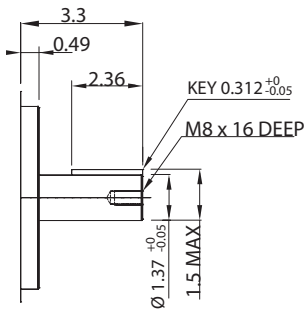

Shaft Code 2

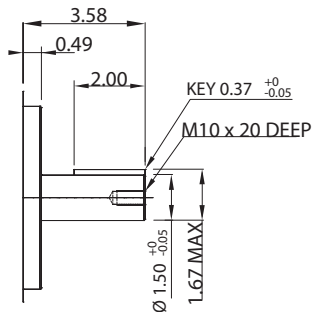

Shaft Code W

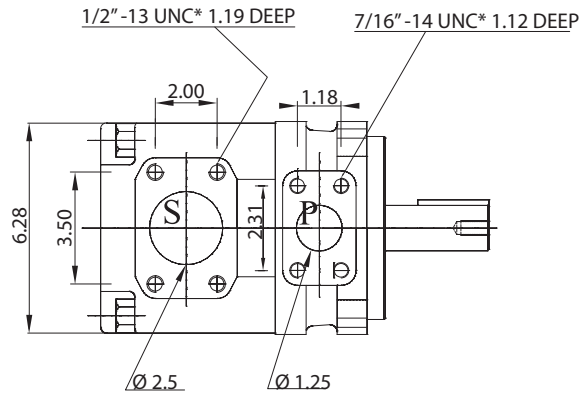

PT7DSW OPERATING CHARACTERISTICS - TYPICAL 115 SUS (24 cSt)

Series	Volumetric Displacement in ³ /rev (cm ³ /rev)	Flow Q in GPM (l/min) @ 1800 RPM			Input Power HP (KW) @ 1800 RPM			P. Max PSI (Bar)	MAX RPM
		p = 0 PSI (0 Bar)	p = 2000 PSI (140 Bar)	p = 4667 PSI (320 Bar)	p = 100 PSI (7 Bar)	p = 2000 PSI (140 Bar)	p = 3500 PSI (240 Bar)		
B14	2.68 (43.9)	20.90 (79.1)	19.15 (72.5)	17.14 (64.9)	3.49 (2.60)	27.76 (20.7)	58.47 (43.6)	3500 (240)	2500
B17	3.36 (55.0)	26.10 (98.8)	24.38 (92.3)	22.38 (84.7)	3.75 (2.80)	33.93 (25.3)	71.88 (53.6)		
B20	4.03 (66.0)	31.33 (118.6)	29.59 (112.0)	27.61 (104.5)	4.02 (3.00)	39.96 (29.8)	85.29 (63.6)		
B24	4.95 (81.1)	38.52 (145.8)	36.77 (139.2)	34.77 (131.6)	4.56 (3.40)	48.41 (36.1)	103.80 (77.4)		
B28	5.49 (89.9)	42.74 (161.8)	41.00 (155.2)	38.99 (147.6)	4.69 (3.50)	53.24 (39.7)	114.66 (85.5)		
B31	6.05 (99.1)	47.10 (178.3)	45.36 (171.7)	43.38 (164.2)	4.96 (3.70)	58.47 (43.6)	125.65 (93.7)		
B35	6.92 (113.4)	53.86 (203.9)	52.09 (197.2)	50.35 (190.6 (1)	0.00 (0.00)	66.25 (49.4)	130.35 (97.2 (1)		
B38	7.36 (120.6)	57.27 (216.8)	55.53 (210.2)	53.79 (203.6 (1)	5.63 (4.20)	70.27 (52.4)	138.39 (103.2 (1)		
B42	8.39 (137.5)	65.30 (247.2)	63.56 (240.6)	62.05 (234.9 (2)	6.03 (4.50)	79.66 (59.4)	149.39 (111.4 (2)	2200	
B45	8.89 (145.7)	69.21 (262.0)	66.99 (253.6)	65.38 (247.5 (3)	6.71 (5.00)	83.68 (62.4)	144.43 (107.7 (3)		
B50	9.64 (157.9)	75.02 (284.0)	72.86 (275.8)	71.67 (271.3 (4)	7.11 (5.30)	90.52 (67.5)	134.50 (100.3 (4)		

(1) B14-B45= 2500 RPM max

(2) B50 = 3000 PSI max. int.

Min Speed : 600 RPM

PT7DSWP - B45 - 3 R 00 - A 1-W1 *

① ② ③ ④ ⑤ ⑥ ⑦ ⑧ ⑨

① Series

② Cam Ring

Volumetric displacement in³/rev (cm³/rev)

B14 = 2.68 (43.9)	B35 = 6.92 (113.4)
B17 = 3.36 (55.0)	B38 = 7.36 (120.6)
B20 = 4.03 (66.0)	B42 = 8.39 (137.5)
B24 = 4.95 (81.1)	B45 = 8.89 (145.7)
B28 = 5.49 (89.9)	B50 = 9.64 (157.9)
331 = 6.05 (99.1)	

③ Type of Shaft

3= Splined (SAE C)

④ Rotation

(viewed from shaft end)

R= clockwise

L= counter-clockwise

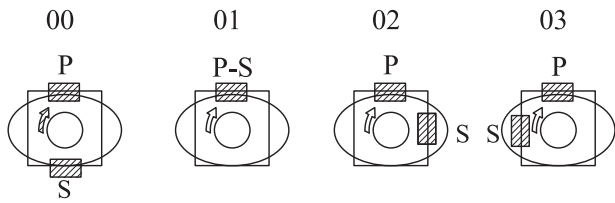

S = Suction port P = Pressure port

⑤ Porting Combination

00=Standard

⑥ Design Letter

⑦ Seal Class

1= S1 HNBR (for mineral oil)

4= S4 EPDM (for fire resistant fluids)

5= S5 Viton (for mineral oil and fire resistant fluids)

⑧ Mounting W/connection variables

PT7DSWP	
UNC (W1)	
P= 1-1/4"	S= 2-1/2"

⑨ Modifications

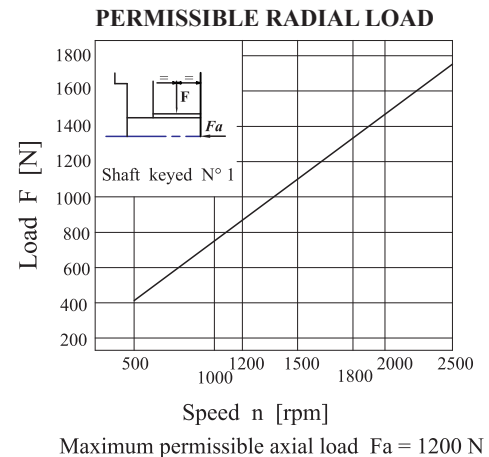
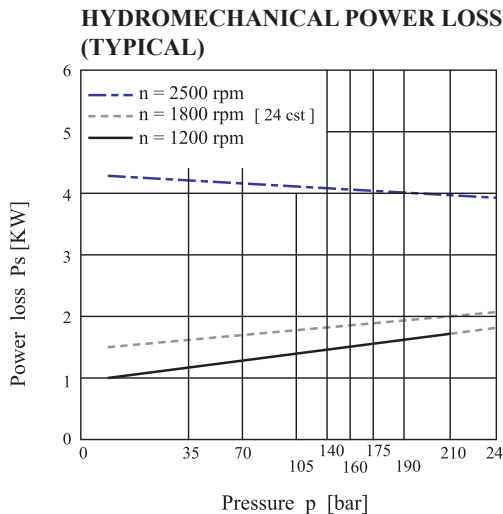
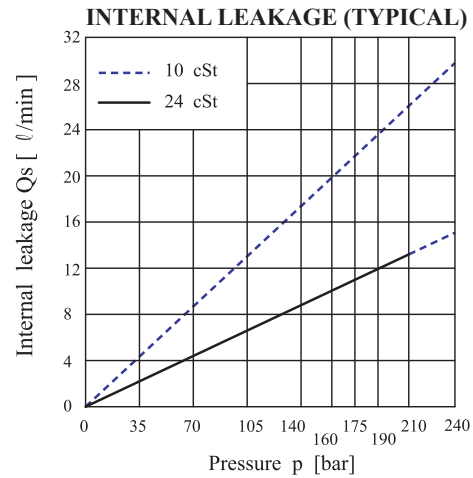

Maximum permissible axial load Fa = 1200 N



PT7DSWP Dimensional Drawing

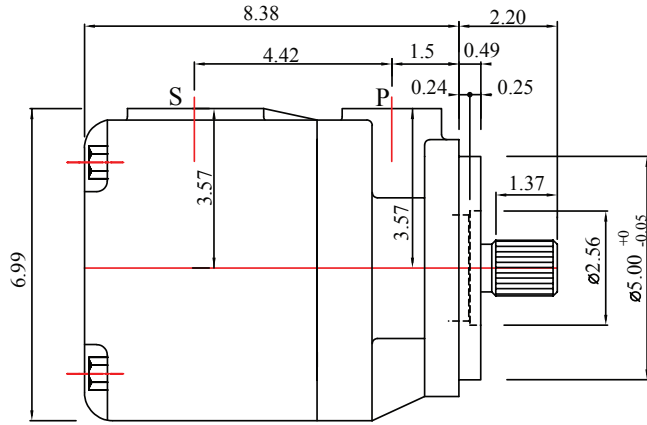
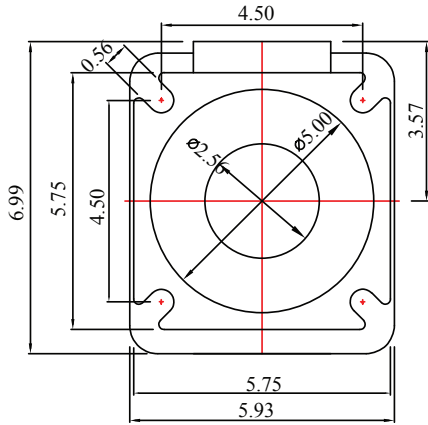

Shaft Code 3

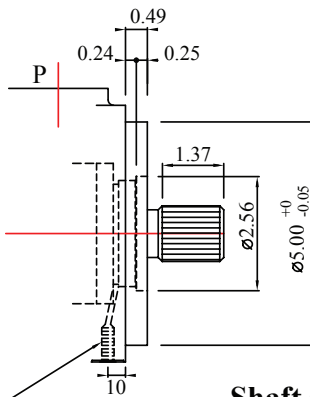

1/4" NPT
DRAIN HOLE
BETWEEN TWO SHAFT
SEALS

Shaft Code 3

SAE C splined shaft
12/24 dp. -14 teeth
30° pressure angle
Flat root side fit.

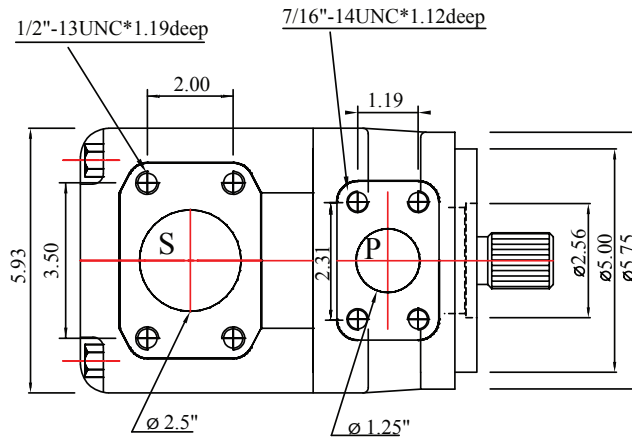

Shaft torque limits(ml/rev x bar)	
Shaft	Vp x P max
3	61200

PT7DSWP OPERATING CHARACTERISTICS - TYPICAL 115 SUS (24 cSt)

Series	Volumetric Displacement in ³ /rev (cm ³ /rev)	Flow Q in GPM (l/min) @ 1800 RPM			Input Power HP (KW) @ 1800 RPM			P. Max PSI (Bar)	MAX RPM
		p = 0 PSI (0 Bar)	p = 2000 PSI (140 Bar)	p = 4667 PSI (320 Bar)	p = 100 PSI (7 Bar)	p = 2000 PSI (140 Bar)	p = 3500 PSI (240 Bar)		
B14	2.68 (43.9)	20.90 (79.1)	19.15 (72.5)	17.14 (64.9)	3.49 (2.60)	27.76 (20.7)	58.47 (43.6)	3500 (240)	2500
B17	3.36 (55.0)	26.10 (98.8)	24.38 (92.3)	22.38 (84.7)	3.75 (2.80)	33.93 (25.3)	71.88 (53.6)		
B20	4.03 (66.0)	31.33 (118.6)	29.59 (112.0)	27.61 (104.5)	4.02 (3.00)	39.96 (29.8)	85.29 (63.6)		
B24	4.95 (81.1)	38.52 (145.8)	36.77 (139.2)	34.77 (131.6)	4.56 (3.40)	48.41 (36.1)	103.80 (77.4)		
B28	5.49 (89.9)	42.74 (161.8)	41.00 (155.2)	38.99 (147.6)	4.69 (3.50)	53.24 (39.7)	114.66 (85.5)		
B31	6.05 (99.1)	47.10 (178.3)	45.36 (171.7)	43.38 (164.2)	4.96 (3.70)	58.47 (43.6)	125.65 (93.7)		
B35	6.92 (113.4)	53.86 (203.9)	52.09 (197.2)	50.35 (190.6 (1)	0.00 (0.00)	66.25 (49.4)	130.35 (97.2 (1)		
B38	7.36 (120.6)	57.27 (216.8)	55.53 (210.2)	53.79 (203.6 (1)	5.63 (4.20)	70.27 (52.4)	138.39 (103.2 (1)		
B42	8.39 (137.5)	65.30 (247.2)	63.56 (240.6)	62.05 (234.9 (2)	6.03 (4.50)	79.66 (59.4)	149.39 (111.4 (2)	2200	
B45	8.89 (145.7)	69.21 (262.0)	66.99 (253.6)	65.38 (247.5 (3)	6.71 (5.00)	83.68 (62.4)	144.43 (107.7 (3)		
B50	9.64 (157.9)	75.02 (284.0)	72.86 (275.8)	71.67 (271.3 (4)	7.11 (5.30)	90.52 (67.5)	134.50 (100.3 (4)		

(1) B14-B45= 2500 RPM max

(2) B50 = 3062 PSI max. int.

Min Speed : 600 RPM

PT6CC/PT6CCM - -022 -008 -1 R 00 - C 100

1
 2
 P1
 P2
 4
5
6
 7
8
9

③

① **Series** PT6CC/PT6CCM - SAE-B 2-Bolt Mount

② **Use for Severe duty shaft only**

③ **Cam Ring for "P1" & "P2"**

Volumetric displacement in $\frac{3}{4}$ rev (cm³/rev)

003/B03 = 0.66 (10.8)	017/B17 = 3.56 (58.3)
005/B05 = 1.05 (17.2)	020/B20 = 3.89 (63.8)
006/B06 = 1.30 (21.3)	022/B22 = 4.29 (70.3)
008/B08 = 1.61 (26.4)	025/B25 = 4.84 (79.3)
010/B10 = 2.08 (34.1)	028/B28 = 5.42 (88.8)
012/B12 = 2.26 (37.1)	031/B31 = 6.10 (100.0)
014/B14 = 2.81 (46.0)	

④ **Type of Shaft**

- 1 = Keyed (No SAE)
- 3 = Splined (SAE BB)
- 5 = Splined (SAE B)
- W version**
- 2 = Keyed (SAE BB)
- R = Keyed (Special)
- T = Splined (SAE j718c)
- X = Keyed (Special)
- V = Keyed (Special)
- W = Keyed (Special)
- Q = Splined (SAE C)

⑤ **Rotation**
(viewed from shaft end)

- R = clockwise
- L = counter-clockwise

⑥ **Porting Combination**
00=Standard

⑦ **Design Letter**

- C = Industrial
- D = Mobile

⑧ **Seal Class**

- 1 = S1 HNBR (for mineral oil)
- 4 = S4 EPDM (for fire resistant fluids)
- 5 = S5 Viton (for mineral oil and fire resistant fluids)

⑨ **Mounting W/connection variables**

Code	P2	P1=1" , S=3"		P1=1" , S=2-1/2"	
		1"	3/4" 1)	1"	3/4" 1)
Unc	00	01	10	11	
Metric	0M	W0	1M	W1	

1) for 46 ml/rev. max.

2) for 126 ml/rev. max.

The large cartridge must be always mounted in the front.

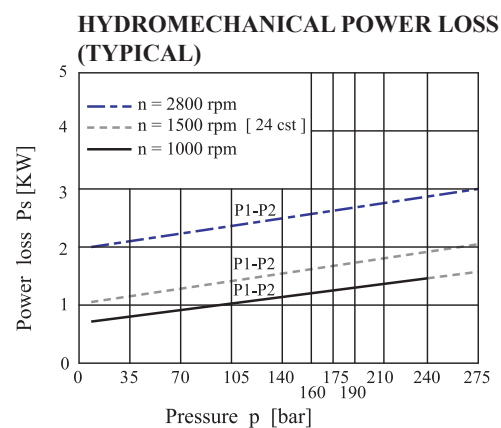
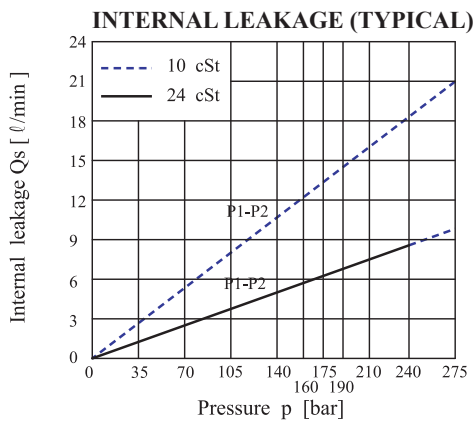

Do not operate pump more than 5 seconds at any speed or viscosity if internal leakage is more than 50% of theoretical flow.

Total leakage is the sum of each section loss at its operating conditions

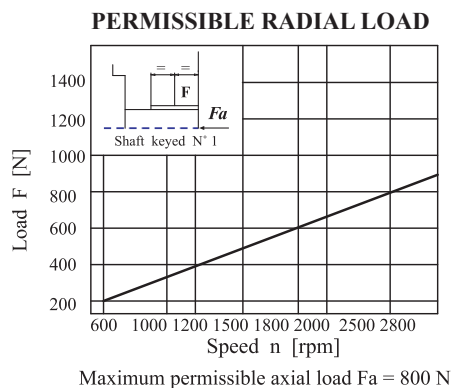



PT6CC Dimensional Drawing

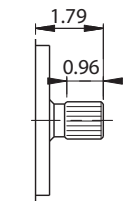
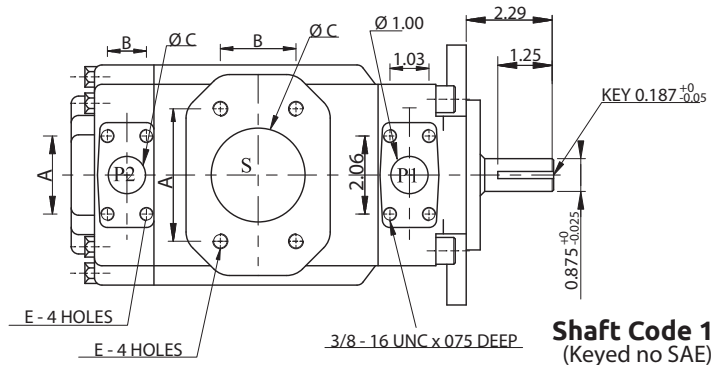
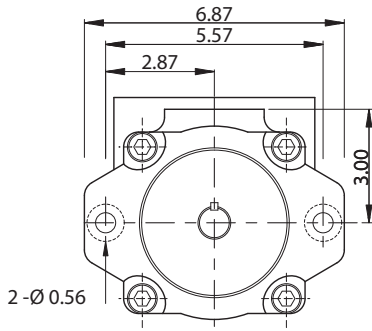

Shaft Code 3
SAE BB Splined Shaft
16/32 dp. - 15 teeth
30° pressure angle.
Flat root side fit.

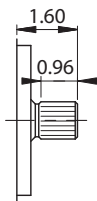

Shaft Code 5
SAE B Splined Shaft
16/32 dp. - 13 teeth
30° pressure angle.
Flat root side fit.

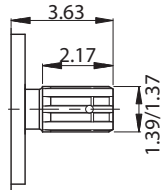

Shaft Code S
DIN 5462
B8 x 32 x 36

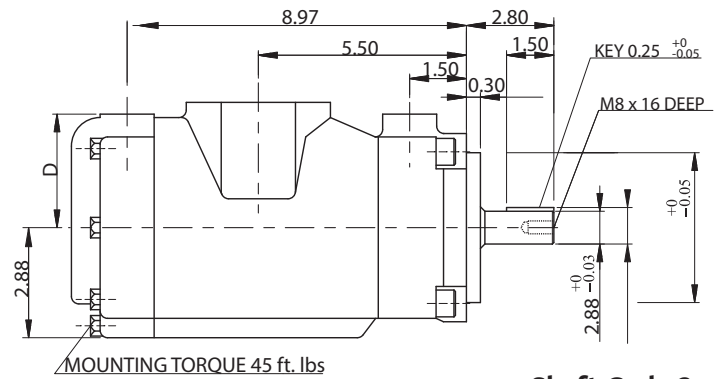
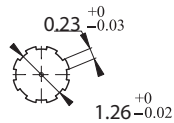

Shaft Code 2
(Keyed SAE BB)

PORT	A	B	C	D	E
S	4.19	2.43	3.00		5/8" - 11 UNC x 1.12 DEEP (M16 x 28.4)
S	3.50	2.00	2.50		1/2" - 13 UNC x 0.94 DEEP (M12 x 24.0)
P2	1.87	0.87	0.75	3.00	3/8" - 16 UNC x 0.75 DEEP (M10 x 19.0)
P3	2.06	1.03	1.00	2.94	

Shaft torque limits in ³ /rev x PSI (cm ³ /rev x Bar)		
Pump	Shaft	Vp x p max.P1+P2
PT6CC	1	12666 (14300)
	2	18972 (21420)
	3	28937 (32670)
	5	18246 (20600)

PT6CC/PT6CCM OPERATING CHARACTERISTICS - TYPICAL 115 SUS (24 cSt)

Pressure Port	Series	Volumetric Displacement in ³ /rev (cm ³ /rev)	Flow Q in GPM (l/min) @ 1500 RPM			Input Power HP (KW) @ 1500 RPM			P. Max PSI (Bar)	MAX RPM
			p = 0 PSI (0 Bar)	p = 2000 PSI (140 Bar)	p = 3500 PSI (240 Bar)	p = 100 PSI (7 Bar)	p = 2000 PSI (140 Bar)	p = 3500 PSI (240 Bar)		
P1 & P2	B/003	0.66 (10.8)	4.28 (16.2)	2.96 (11.2)	2.03 (7.7)	1.74 (1.30)	7.11 (5.30)	11.26 (8.40)	4010 (275)	2800
	B/005	1.05 (17.2)	6.82 (25.8)	5.49 (20.8)	4.57 (17.3)	1.88 (1.40)	10.06 (7.50)	16.36 (12.20)		
	B/006	1.30 (21.3)	8.43 (31.9)	7.11 (26.9)	6.18 (23.4)	2.01 (1.50)	11.94 (8.90)	19.71 (14.70)		
	B/008	1.61 (26.4)	10.46 (39.6)	9.14 (34.6)	8.22 (31.1)	2.15 (1.60)	14.35 (10.70)	23.74 (17.70)		
	B/010	2.08 (34.1)	13.50 (51.1)	12.18 (46.1)	11.25 (42.6)	2.28 (1.70)	17.97 (13.40)	29.90 (22.30)		
	B/012	2.26 (37.1)	14.69 (55.6)	13.37 (50.6)	12.44 (47.1)	2.28 (1.70)	19.31 (14.40)	32.32 (24.10)		
	B/014	2.81 (46.0)	18.23 (69.0)	16.91 (64.0)	15.98 (60.5)	2.55 (1.90)	23.60 (17.60)	39.56 (29.50)		
	B/017	3.56 (58.3)	23.09 (87.4)	21.77 (82.4)	20.84 (78.9)	2.82 (2.10)	29.37 (21.90)	49.48 (36.90)		
	B/020	3.89 (63.8)	25.28 (95.7)	23.96 (90.7)	23.04 (87.2)	2.95 (2.20)	31.92 (23.80)	53.91 (40.20)		
	B/022	4.29 (70.3)	27.84 (105.4)	26.52 (100.4)	25.60 (96.9)	3.08 (2.30)	35.00 (26.10)	59.14 (44.10)		
	B/025 ₍₁₎	4.84 (79.3)	31.41 (118.9)	30.09 (113.9)	29.16 (110.4)	3.35 (2.50)	39.16 (29.20)	66.38 (49.50)		
	B/028 _(1,2)	5.42 (88.8)	35.19 (133.2)	33.87 (128.2)	33.23 (125.8)	3.75 (2.80)	43.85 (32.70)	65.04 (48.50)	3062 (210)	2500
B/031 _(1,2)	6.10 (100.0)	39.63 (150.0)	38.30 (145.0)	37.67 (142.6)	3.75 (2.80)	48.95 (36.50)	73.09 (54.50)			

(1) B/025 - B/028 - B/031 = 2500 RPM

(2) B/028 - B/031 = 3062 PSI max. int.

Min Speed : 600 RPM



PT6CCZ Ordering Code

PT6CCZ - B22-B08 -X R 00 - A 1 00

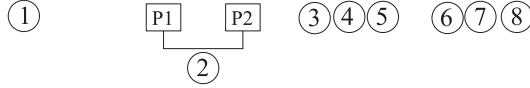

① **Series** PT6CCZ- SAE-B 2-Bolt Mount
Mounting flange J744c

② **Cam Ring for "P1" & "P2"**

Volumetric displacement in³/ rev (cm³/rev)

B03 = 0.66 (10.8)	B17 = 3.56 (58.3)
B05 = 1.05 (17.2)	B20 = 3.89 (63.8)
B06 = 1.30 (21.3)	B22 = 4.29 (70.3)
B08 = 1.61 (26.4)	B25 = 4.84 (79.3)
B10 = 2.08 (34.1)	B28 = 5.42 (88.8)
B12 = 2.26 (37.1)	B31 = 6.10 (100.0)
B14 = 2.81 (46.0)	

③ **Type of Shaft**

- X = Keyed (No SAE)
- W = Keyed (No SAE)
- V = Keyed (No SAE)
- S = Splined (DIN 5462)

④ **Rotation**

- (viewed from shaft end)
- R = clockwise
- L = counter-clockwise

⑤ **Porting Combination**
00=Standard

⑥ **Design Letter**

⑦ **Seal Class**

- 1= S1 HNBR (for mineral oil)
- 4= S4 EPDM (for fire resistant fluids)
- 5= S5 Viton (for mineral oil and fire resistant fluids)

⑧ **Mounting W/connection variables**

		P1=1" , S=3"		P1=1" ,S=2-1/2"	
		1"	3/4" 1)	1"	3/4" 1)
Code	Unc	00	01	10	11
	Metric	0M	W0	1M	W1

1) for 46 ml/rev. max.

2) for 126 ml/rev. max.

The large cartridge must be always mounted in the front.

INTERNAL LEAKAGE (TYPICAL)

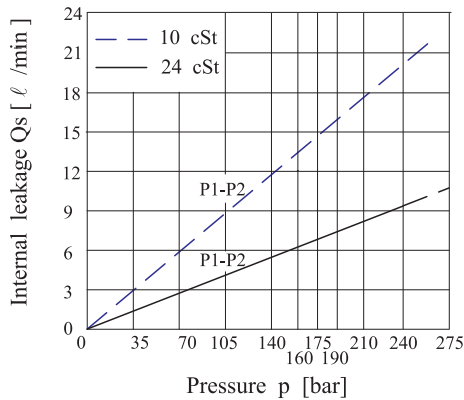

Do not operate pump more than 5 seconds at any speed or viscosity if internal leakage is more than 50% of theoretical flow.

Total leakage is the sum of each section loss at its operating conditions

HYDROMECHANICAL POWER LOSS (TYPICAL)

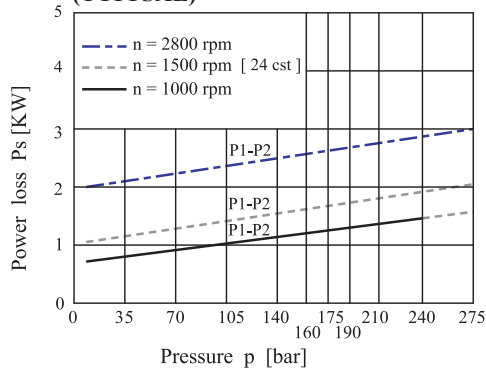

NOISE LEVEL (TYPICAL)

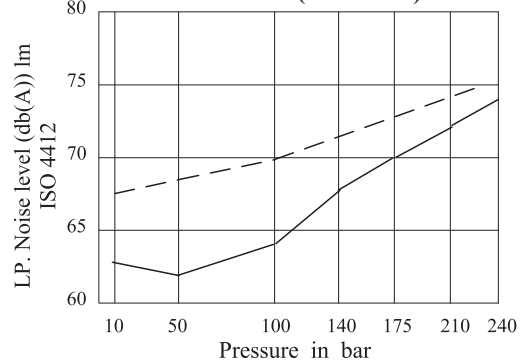

Double pump noise level is given with each section discharging at the pressure noted on the curve



PT6CCZ Dimensional Drawing

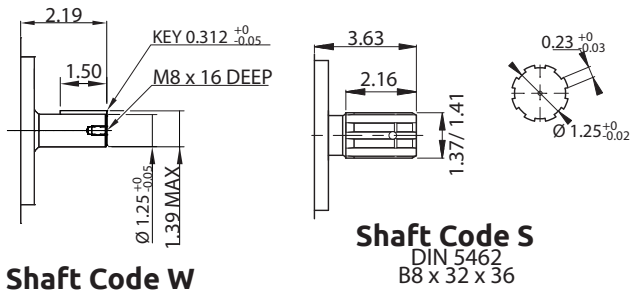
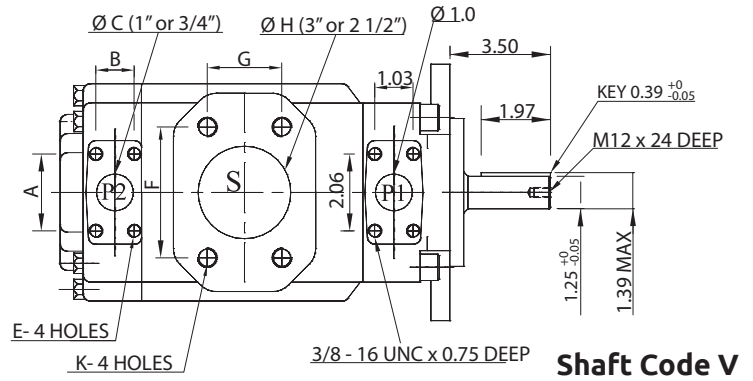
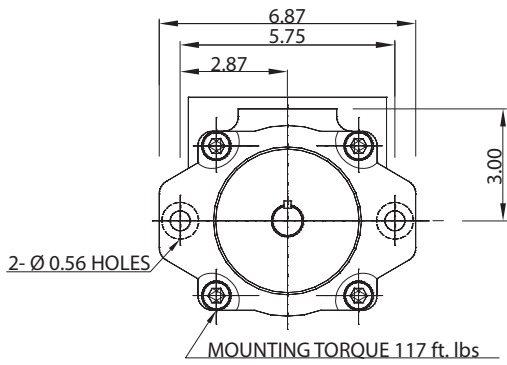

Shaft Code W

Shaft Code S
DIN 5462
B8 x 32 x 36

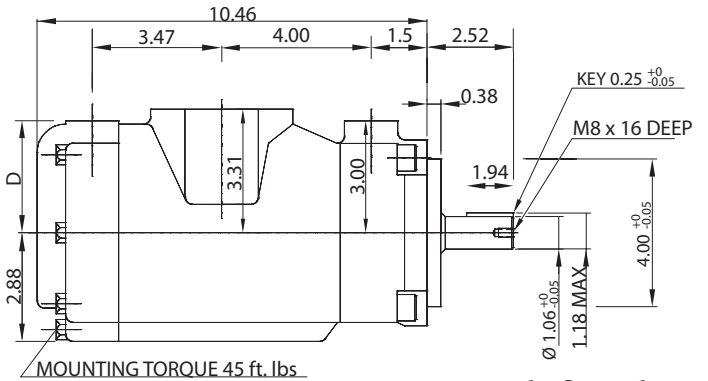

Shaft Code X

Alternate Port								
	S = 3"				S = 2 1/2"			
F	4.19				3.50			
G	2.44				2.00			
Ø H	3.00				2.50			
CODE	00	01	0M	W0	10	11	1M	W1
A	2.06	1.87	2.06	1.87	2.06	1.87	2.06	1.87
B	1.03	0.87	1.03	0.87	1.03	0.87	1.03	0.87
Ø C	1.00	0.75	1.00	0.75	1.00	0.75	1.00	0.75
D	2.94	3.00	2.94	3.00	2.94	3.00	2.94	3.00
E	3/8" - 16 UNC x 19 DEEP		M10 x 19 DEEP		3/8" - 16 UNC x 19 DEEP		M10 x 19 DEEP	
K	5/8" - 11 UNC x 28.4 DEEP		M16 x 28.4 DEEP		1/2" - 11 UNC x 23.9 DEEP		M16 x 24.0 DEEP	

Shaft torque limits (m ^l /rev x Bar)		
Pump	Shaft	Vp x p max. P1 + P2
PT6CCZ	X	25400
	V	32670
	W	32670

PT6CCZ OPERATING CHARACTERISTICS - TYPICAL 115 SUS (24 cSt)

Pressure Port	Series	Volumetric Displacement in ³ /rev (cm ³ /rev)	Flow Q in GPM (l/min) @ 1500 RPM			Input Power HP (KW) @ 1500 RPM			P. Max PSI (Bar)	MAX RPM
			p = 0 PSI (0 Bar)	p = 2000 PSI (140 Bar)	p = 3500 PSI (240 Bar)	p = 100 PSI (7 Bar)	p = 2000 PSI (140 Bar)	p = 3500 PSI (240 Bar)		
P1 & P2	B03	0.66 (10.8)	4.28 (16.2)	2.96 (11.2)	2.03 (7.7)	1.74 (1.30)	7.11 (5.30)	11.26 (8.40)	4010 (275)	2800
	B05	1.05 (17.2)	6.82 (25.8)	5.49 (20.8)	4.57 (17.3)	1.88 (1.40)	10.06 (7.50)	16.36 (12.20)		
	B06	1.30 (21.3)	8.43 (31.9)	7.11 (26.9)	6.18 (23.4)	2.01 (1.50)	11.94 (8.90)	19.71 (14.70)		
	B08	1.61 (26.4)	10.46 (39.6)	9.14 (34.6)	8.22 (31.1)	2.15 (1.60)	14.35 (10.70)	23.74 (17.70)		
	B10	2.08 (34.1)	13.50 (51.1)	12.18 (46.1)	11.25 (42.6)	2.28 (1.70)	17.97 (13.40)	29.90 (22.30)		
	B12	2.26 (37.1)	14.69 (55.6)	13.37 (50.6)	12.44 (47.1)	2.28 (1.70)	19.31 (14.40)	32.32 (24.10)		
	B14	2.81 (46.0)	18.23 (69.0)	16.91 (64.0)	15.98 (60.5)	2.55 (1.90)	23.60 (17.60)	39.56 (29.50)		
	B17	3.56 (58.3)	23.09 (87.4)	21.77 (82.4)	20.84 (78.9)	2.82 (2.10)	29.37 (21.90)	49.48 (36.90)		
	B20	3.89 (63.8)	25.28 (95.7)	23.96 (90.7)	23.04 (87.2)	2.95 (2.20)	31.92 (23.80)	53.91 (40.20)		
	B22	4.29 (70.3)	27.84 (105.4)	26.52 (100.4)	25.60 (96.9)	3.08 (2.30)	35.00 (26.10)	59.14 (44.10)		
	B25 ⁽¹⁾	4.84 (79.3)	31.41 (118.9)	30.09 (113.9)	29.16 (110.4)	3.35 (2.50)	39.16 (29.20)	66.38 (49.50)		
	B28 ^(1,2)	5.42 (88.8)	35.19 (133.2)	33.87 (128.2)	33.23 (125.8)	3.75 (2.80)	43.85 (32.70)	65.04 (48.50)		
	B31 ^(1,2)	6.10 (100.0)	39.63 (150.0)	38.30 (145.0)	37.67 (142.6)	3.75 (2.80)	48.95 (36.50)	73.09 (54.50)		

(1) B25 - B28 - B31 = 2500 RPM max.

(2) B28 - B31 = 3062 PSI max. int.

Min Speed : 600 RPM



PT6DC Ordering Code

PT6DC/PT6DCM - W - 038 - 022 - 1 R 00 - B 1 - 00 *

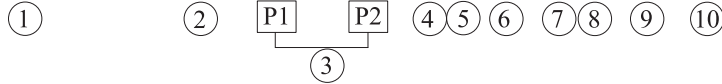

① **Series** PT6DC/PT6DCM - SAE-C 2-Bolt Mount

② **Use for Severe duty shaft only**

③ **Cam Ring for "P1"**

Volumetric displacement in ³/ rev (cm³/rev)

014/B14 = 2.90 (47.6)	035/B35 = 6.77 (111.0)
017/B17 = 3.55 (58.2)	038/B38 = 7.34 (120.3)
020/B20 = 4.03 (66.0)	042/B42 = 8.30 (136.0)
024/B24 = 4.85 (79.5)	045/B45 = 8.89 (145.7)
028/B28 = 5.47 (89.7)	050/B50 = 9.64 (158.0)
031/B31 = 6.00 (98.3)	

Cam Ring for "P2"

003/B03 = 0.66 (10.8)	017/B17 = 3.56 (58.3)
005/B05 = 1.05 (17.2)	020/B20 = 3.89 (63.8)
006/B06 = 1.30 (21.3)	022/B22 = 4.29 (70.3)
008/B08 = 1.61 (26.4)	025/B25 = 4.84 (79.3)
010/B10 = 2.08 (34.1)	028/B28 = 5.42 (88.8)
012/B12 = 2.26 (37.1)	031/B31 = 6.10 (100.0)
014/B14 = 2.81 (46.0)	

④ **Type of Shaft**

- 1 = Keyed (SAE C)
 - 2 = Keyed (No SAE)
 - 3 = Splined (SAE C)
 - 4 = Splined (SAE C spec long)
- Severe Duty (PT6DCW only)**
- 5 = Keyed (No SAE)

HYDROMECHANICAL POWER LOSS (TYPICAL)

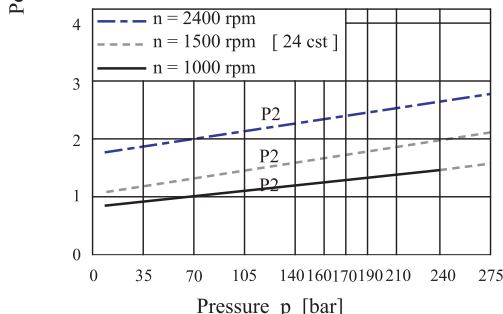
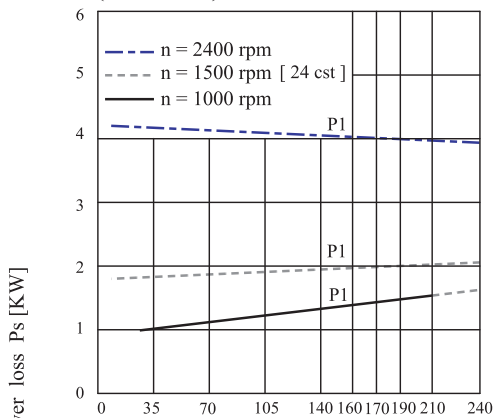

Total hydromechanical power loss is the sum of each sections loss at its operating conditions.

⑤ **Rotation**
(viewed from shaft end)

- R= clockwise
- L= counter-clockwise

⑥ **Porting Combination**
00=Standard

⑦ **Design Letter**

- B = Industrial
- C = Mobile

⑧ **Seal Class**

- 1= S1 HNBR (for mineral oil)
- 4= S4 EPDM (for fire resistant fluids)
- 5= S5 Viton (for mineral oil and fire resistant fluids)

⑨ **Mounting W/connection variables**

	UNC		METRIC	
	00	01	M0	M1
P2	1"	3/4"	1"	3/4"

⑩ **Modifications**

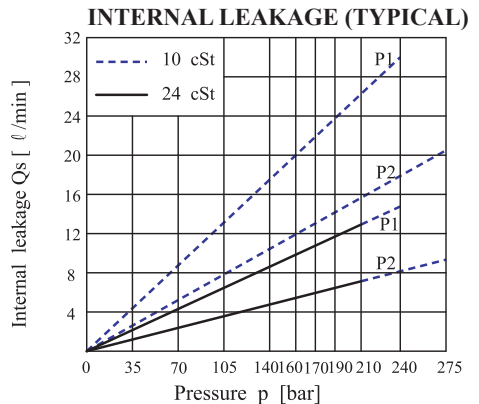

Do not operate pump more than 5 seconds at any speed or viscosity if internal leakage is more than 50% of theoretical flow.

Total leakage is the sum of each section loss at its operating conditions

PERMISSIBLE RADIAL LOAD

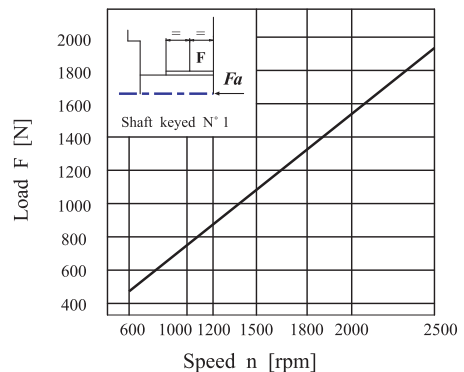

Maximum permissible axial load Fa = 1200 N



PT6DC Dimensional Drawing

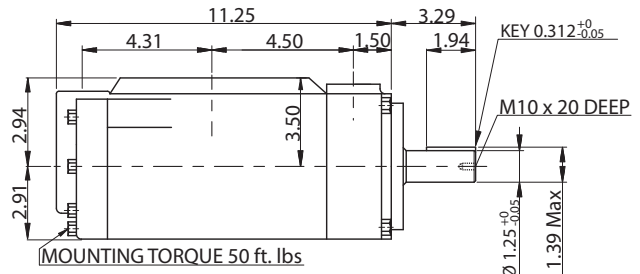
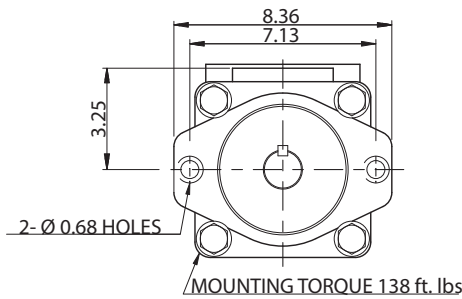

Shaft Code 1
(Keyed SAE C)

PT6DCW

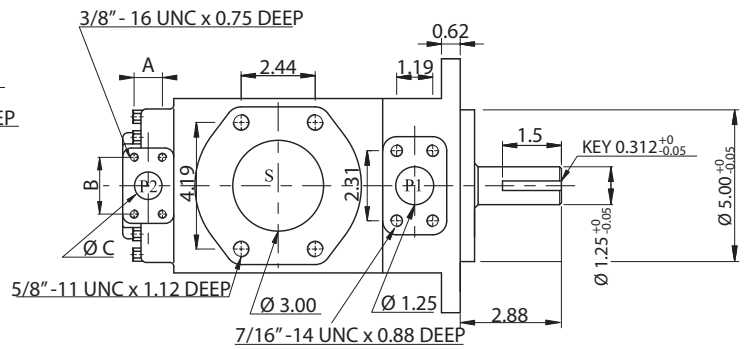
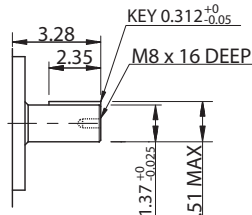
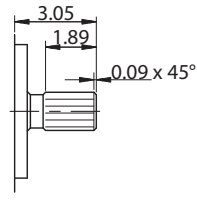

Shaft Code 2
(Keyed no SAE)

Shaft Code 3
SAE C Splined Shaft
12/24 dp. - 14 teeth
30° pressure angle
Flat root side fit.

Shaft Code 5
SAE C Long Spec
Splined Shaft
12/24 dp. - 14 teeth
30° pressure angle
Flat root side fit.

Shaft Code 5
(Keyed no SAE)

Shaft torque limits in ³ /rev x PSI (cm ³ /rev x Bar)		
Pump	Shaft	Vp x p max. P1 + P2
PT6DC	1	38299 (43240)
	2	30638 (34590)
	3	54207 (61200)
	4	54207 (61200)
	5	49247 (55600)

Alternate Connect. Variables		
	00 & M0	01 & M1
A	1.03	0.875
B	2.06	1.875
C	1.00	0.750

PT6DC/PT6DCM OPERATING CHARACTERISTICS - TYPICAL 115 SUS (24 cSt)

Pressure Port	Series	Volumetric Displacement in ³ /rev (cm ³ /rev)	Flow Q in GPM (l/min) @ 1500 RPM			Input Power HP (KW) @ 1500 RPM			P. Max PSI (Bar)	MAX RPM
			p = 0 PSI (0 Bar)	p = 2000 PSI (140 Bar)	p = 3500 PSI (240 Bar)	p = 100 PSI (7 Bar)	p = 2000 PSI (140 Bar)	p = 3500 PSI (240 Bar)		
P1	B/014	2.90 (47.6)	18.86 (71.4)	16.41 (62.1)	14.77 (55.9)	3.08 (2.3)	24.81 (18.5)	41.04 (30.6)	3500 (240)	2500
	B/017	3.55 (58.2)	23.06 (87.3)	20.61 (78.0)	18.97 (71.8)	3.35 (2.5)	29.77 (22.2)	49.62 (37.0)		
	B/020	4.03 (66.0)	26.15 (99.0)	23.70 (89.7)	22.06 (83.5)	3.75 (2.8)	33.39 (24.9)	55.92 (41.7)		
	B/024	4.85 (79.5)	31.52 (119.3)	29.06 (110.0)	27.42 (103.8)	4.02 (3.0)	39.69 (29.6)	66.78 (49.8)		
	B/028	5.47 (89.7)	35.53 (134.5)	33.07 (125.2)	31.44 (119.0)	4.29 (3.2)	44.52 (33.2)	74.96 (55.9)		
	B/031	6.00 (98.3)	38.97 (147.5)	36.48 (138.1)	34.84 (131.9)	4.43 (3.3)	48.54 (36.2)	81.80 (61.0)		
	B/035	6.77 (111.0)	43.98 (166.5)	41.53 (157.2)	39.89 (151.0)	4.69 (3.5)	54.58 (40.7)	92.13 (68.7)		
	B/038	7.34 (120.3)	47.66 (180.4)	45.20 (171.1)	43.56 (164.9)	4.96 (3.7)	58.87 (43.9)	99.64 (74.3)		
	B/042 ⁽¹⁾	8.30 (136.0)	53.89 (204.0)	51.43 (194.7)	49.80 (188.5)	5.36 (4.0)	66.25 (49.4)	112.24 (83.7)		
B/045 ⁽¹⁾	8.89 (145.7)	57.72 (218.5)	55.26 (209.2)	53.63 (203.0)	5.50 (4.1)	70.81 (52.8)	120.02 (89.5)	2200		
B/050 ⁽¹⁾	9.64 (158.0)	62.61 (237.0)	60.15 (227.7)	59.17 (224.0 (2)	5.90 (4.4)	76.44 (57.0)	113.99 (85.0 (2)	3062 (210)		
P2	B/003	0.66 (10.8)	4.28 (16.2)	2.96 (11.2)	2.03 (7.7)	1.74 (1.3)	7.11 (5.3)	11.26 (8.4)	4010 (275)	2500
	B/005	1.05 (17.2)	6.82 (25.8)	5.49 (20.8)	4.57 (17.3)	1.88 (1.4)	10.06 (7.5)	16.36 (12.2)		
	B/006	1.30 (21.3)	8.43 (31.9)	7.11 (26.9)	6.18 (23.4)	2.01 (1.5)	11.94 (8.9)	19.71 (14.7)		
	B/008	1.61 (26.4)	10.46 (39.6)	9.14 (34.6)	8.22 (31.1)	2.15 (1.6)	14.35 (10.7)	23.74 (17.7)		
	B/010	2.08 (34.1)	13.50 (51.1)	12.18 (46.1)	11.25 (42.6)	2.28 (1.7)	17.97 (13.4)	29.90 (22.3)		
	B/012	2.26 (37.1)	14.69 (55.6)	13.37 (50.6)	12.44 (47.1)	2.28 (1.7)	19.31 (14.4)	32.32 (24.1)		
	B/014	2.81 (46.0)	18.23 (69.0)	16.91 (64.0)	15.98 (60.5)	2.55 (1.9)	23.60 (17.6)	39.56 (29.5)		
	B/017	3.56 (58.3)	23.09 (87.4)	21.77 (82.4)	20.84 (78.9)	2.82 (2.1)	29.37 (21.9)	49.48 (36.9)		
	B/020	3.89 (63.8)	25.28 (95.7)	23.96 (90.7)	23.04 (87.2)	2.95 (2.2)	31.92 (23.8)	53.91 (40.2)		
	B/022	4.29 (70.3)	27.84 (105.4)	26.52 (100.4)	25.60 (96.9)	3.08 (2.3)	35.00 (26.1)	59.14 (44.1)		
	B/025	4.84 (79.3)	31.41 (118.9)	30.09 (113.9)	29.16 (110.4)	3.35 (2.5)	39.16 (29.2)	66.38 (49.5)		
	B/028	5.42 (88.8)	35.19 (133.2)	33.87 (128.2)	33.23 (125.8 (2)	3.75 (2.8)	43.85 (32.7)	65.04 (48.5 (2)		
B/031	6.10 (100.0)	39.63 (150.0)	38.30 (145.0)	37.67 (142.6 (2)	3.75 (2.8)	48.95 (36.5)	72.95 (54.4 (2)			

(1) B/042 - B/045 - B/050 = 2000 RPM max.

(1) B/028 - B/031 - B/050 = 3062 PSI max.

Min Speed : 600 RPM



PT6DDS Ordering Code

PT6DDS/PT6DDSM -038 -022 -1 R 00 -C 1 - 00 *

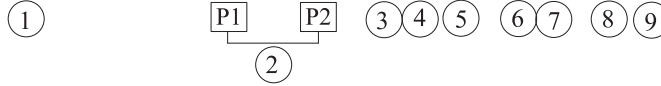

① **Series**
PT6DDS/PT6DDSM - SAE-C 2 & 4 Bolt Mount

② **Cam Ring for "P1" & "P2"**
Volumetric displacement in³/ rev (cm³/rev)

014/B14 = 2.90 (47.6)	035/B35 = 6.77 (111.0)
017/B17 = 3.55 (58.2)	038/B38 = 7.34 (120.3)
020/B20 = 4.03 (66.0)	042/B42 = 8.30 (136.0)
024/B24 = 4.85 (79.5)	045/B45 = 8.89 (145.7)
028/B28 = 5.47 (89.7)	050/B50 = 9.64 (158.0)
031/B31 = 6.00 (98.3)	

③ **Type of Shaft**
1 = Keyed (SAE C)
2 = Keyed (SAE CC)
3 = Splined (SAE C)
4 = Splined (SAE BB)
5 = Keyed (No SAE)

④ **Rotation**
(viewed from shaft end)
R= clockwise
L= counter-clockwise

⑤ **Porting Combination**
00=Standard

⑥ **Design Letter**

⑦ **Seal Class**
1= S1 HNBR (for mineral oil)
4= S4 EPDM (for fire resistant fluids)
5= S5 Viton (for mineral oil and fire resistant fluids)

⑧ **Mounting W/connection variables**

P1 & P2 = 1-1/4" S = 4"		
PT6DDS	Unc	Metric
	00	M0

⑨ **Modifications**

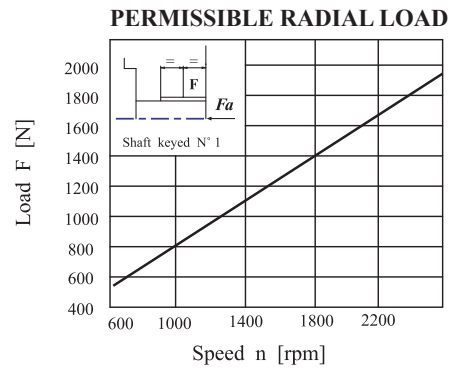
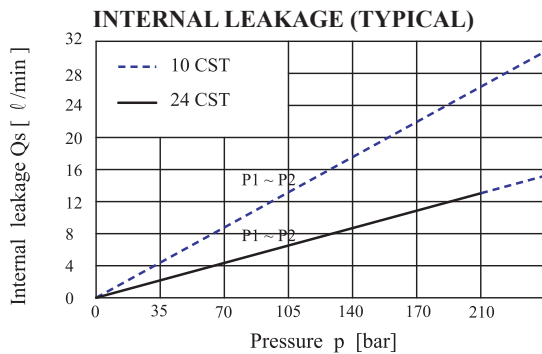

Maximum permissible axial load Fa = 1200 N

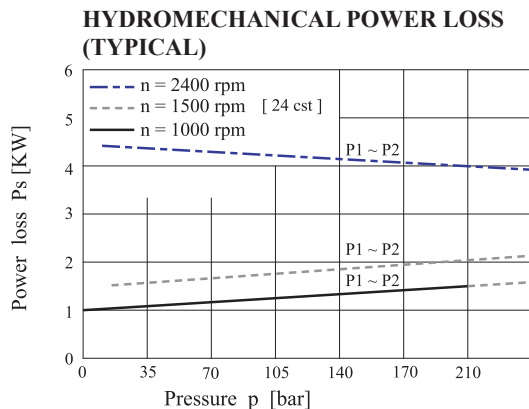

Total hydromechanical power loss is the sum of each sections loss at its operating conditions.

Do not operate pump more than 5 seconds at any speed or viscosity if internal leakage is more than 50% of theoretical flow.

Total leakage is the sum of each section loss at its operating conditions



PT6DDS Dimensional Drawing

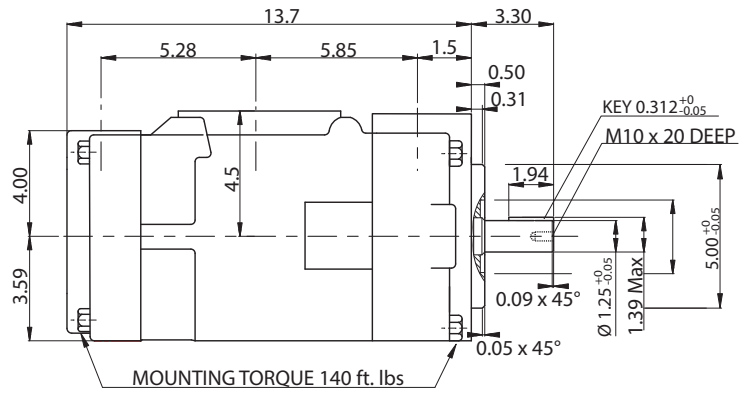
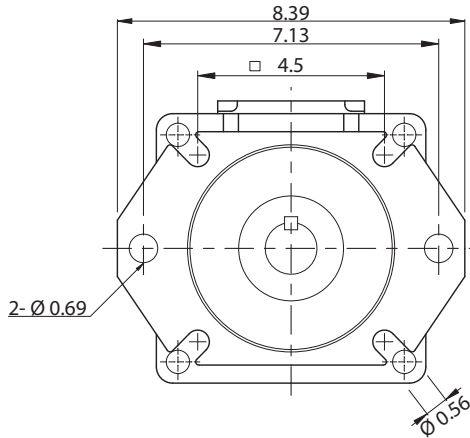

Shaft Code 1
(Keyed SAE C)

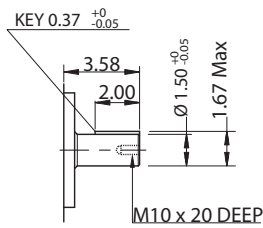

Shaft Code 2
(Keyed SAE CC)

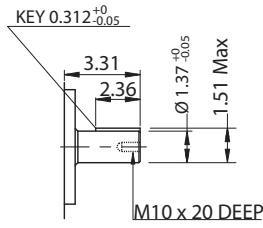

Shaft Code 5
(Keyed no SAE)

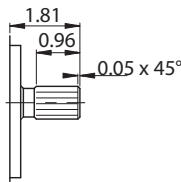

Shaft Code 4
SAE BB Splined Shaft
16/32 dp. - 15 teeth
30° pressure angle
Flat root side fit.

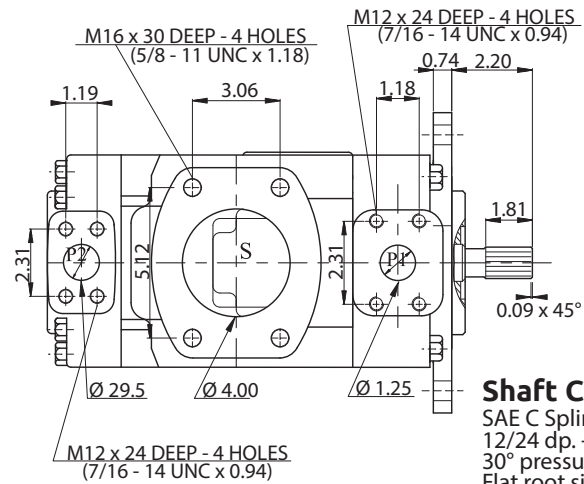

Shaft Code 3
SAE C Splined Shaft
12/24 dp. - 14 teeth
30° pressure angle
Flat root side fit.

Shaft torque limits in ³ /rev x PSI (cm ³ /rev x Bar)		
Pump	Shaft	Vp x p max. P1 + P2
PT6DDS	1	38299 (43240)
	3	54152 (61200)
	4	31780 (35880)
	5	40035 (55600)

PT6DDS/PT6DDSM OPERATING CHARACTERISTICS - TYPICAL 115 SUS (24 cst)

Pressure Port	Series	Volumetric Displacement		Flow Q in GPM (l/min) @ 1500 RPM			Input Power HP (KW) @ 1500 RPM			P. Max PSI (Bar)	MAX RPM						
		in ³ /rev	(cm ³ /rev)	p = 0 PSI (0 Bar)	p = 2000 PSI (140 Bar)	p = 3500 PSI (240 Bar)	p = 100 PSI (7 Bar)	p = 2000 PSI (140 Bar)	p = 3500 PSI (240 Bar)								
P1 & P2	B/014	2.90	(47.6)	18.86	(71.4)	16.41	(62.1)	14.77	(55.9)	3.08	(2.3)	24.81	(18.5)	41.04	(30.6)	3500 (240)	2500
	B/017	3.55	(58.2)	23.06	(87.3)	20.61	(78.0)	18.97	(71.8)	3.35	(2.5)	29.77	(22.2)	49.62	(37.0)		
	B/020	4.03	(66.0)	26.15	(99.0)	23.70	(89.7)	22.06	(83.5)	3.75	(2.8)	33.39	(24.9)	55.92	(41.7)		
	B/024	4.85	(79.5)	31.52	(119.3)	29.06	(110.0)	27.42	(103.8)	4.02	(3.0)	39.69	(29.6)	66.78	(49.8)		
	B/028	5.47	(89.7)	35.53	(134.5)	33.12	(125.2)	31.44	(119.0)	4.29	(3.2)	44.52	(33.2)	74.96	(55.9)		
	B/031	6.00	(98.3)	38.97	(147.5)	36.48	(138.1)	34.84	(131.9)	4.43	(3.3)	48.54	(36.2)	81.80	(61.0)		
	B/035	6.77	(111.0)	43.98	(166.5)	41.53	(157.2)	39.89	(151.0)	4.69	(3.5)	54.58	(40.7)	92.13	(68.7)		
	B/038	7.34	(120.3)	47.66	(180.4)	45.20	(171.1)	43.56	(164.9)	4.96	(3.7)	58.87	(43.9)	99.64	(74.3)		
	B/042 ⁽¹⁾	8.30	(136.0)	53.89	(204.0)	51.43	(194.7)	49.80	(188.5)	5.36	(4.0)	66.25	(49.4)	112.24	(83.7)	3062 (210)	2200
	B/045 ⁽¹⁾	8.89	(145.7)	57.72	(218.5)	55.26	(209.2)	53.63	(203.0)	5.50	(4.1)	70.81	(52.8)	120.02	(89.5)		
	B/050 ⁽¹⁾	9.64	(158.0)	62.61	(237.0)	60.15	(227.7)	59.17	(224.0)	5.90	(4.4)	76.44	(57.0)	113.99	(85.0)	(2)	

(1) B/042 - B/045 - B/050= 2200 RPM max.

(2) B/050 = 3062 PSI max. int.

Min Speed : 600 RPM

PT6EC/PT6ECM - * - 066 - 014 - 1 R 00 - B 1

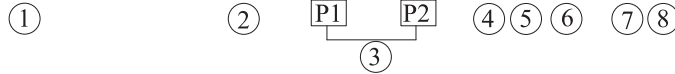

① **Series** PT6EC/PT6ECM - SAE-C 2-Bolt Mount

② **Y-Metric port connection, Omit for UNC**

③ **Cam Ring for "P1" & "P2"**

Volumetric displacement in³/rev (cm³/rev)

042 = 8.07 (132.3)	062 = 12.00 (196.7)
045 = 8.69 (142.4)	066 = 13.02 (213.3)
050 = 9.67 (158.5)	072 = 13.86 (227.1)
052 = 10.06 (164.8)	085 = 16.46 (269.8)

Cam Ring for "P2"

003/B03 = 0.66 (10.8)	017/B17 = 3.56 (58.3)
005/B05 = 1.05 (17.2)	020/B20 = 3.89 (63.8)
006/B06 = 1.30 (21.3)	022/B22 = 4.29 (70.3)
008/B08 = 1.61 (26.4)	025/B25 = 4.84 (79.3)
010/B10 = 2.08 (34.1)	028/B28 = 5.42 (88.8)
012/B12 = 2.26 (37.1)	031/B31 = 6.10 (100.0)
014/B14 = 2.81 (46.0)	

④ **Type of Shaft**

- 1 = Keyed (SAE CC)
- 2 = Keyed (No SAE)
- 3 = Splined (SAE C)
- 4 = Splined (SAE CC)

⑤ **Rotation**

- (viewed from shaft end)
- R = clockwise
- L = counter-clockwise

⑥ **Porting Combination**

- 00 = Standard

⑦ **Design Letter**

- B = Industrial
- C = Mobile

⑧ **Seal Class**

- 1 = S1 HNBR (for mineral oil)
- 4 = S4 EPDM (for fire resistant fluids)
- 5 = S5 Viton (for mineral oil and fire resistant fluids)

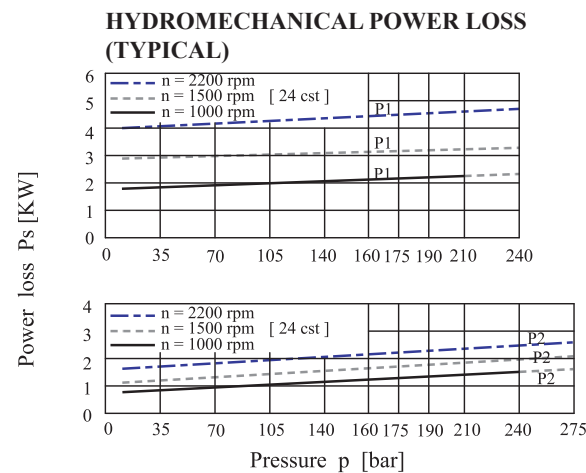
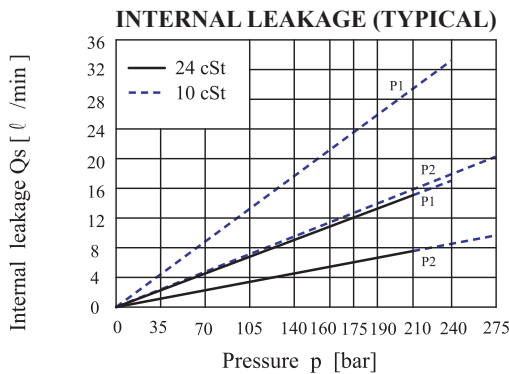

Total hydromechanical power loss is the sum of each sections loss at its operating conditions.

Do not operate pump more than 5 seconds at any speed or viscosity if internal leakage is more than 50% of theoretical flow.

Total leakage is the sum of each section loss at its operating conditions

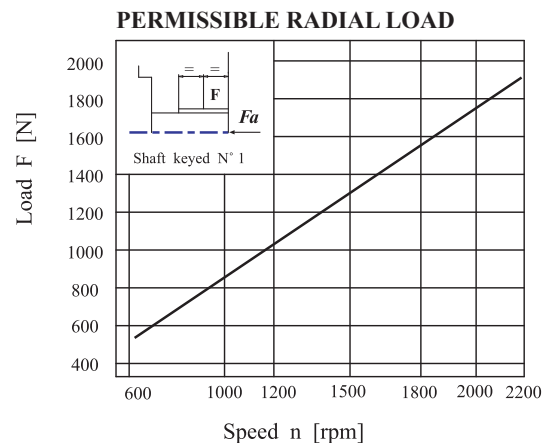

Maximum permissible axial load $F_a = 2000$ N



PT6EC Dimensional Drawing

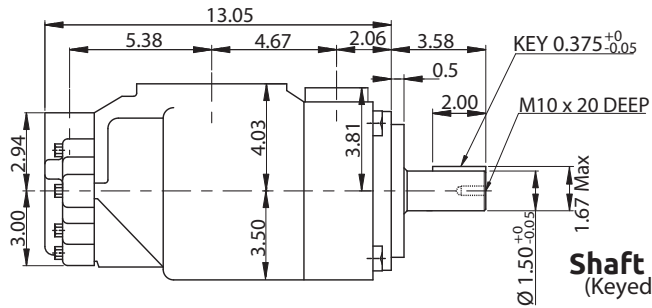
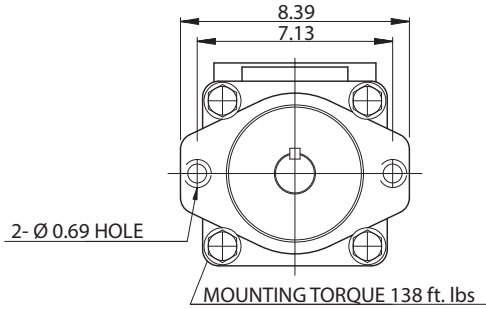

Shaft Code 1
(Keyed SAE CC)

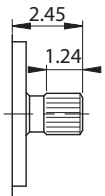

Shaft Code 4
SAE CC Splined Shaft
12/24 dp. - 17 teeth
30° pressure angle
Flat root side fit.

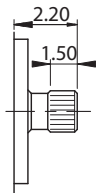

Shaft Code 3
SAE C Splined Shaft
12/24 dp. - 14 teeth
30° pressure angle
Flat root side fit.

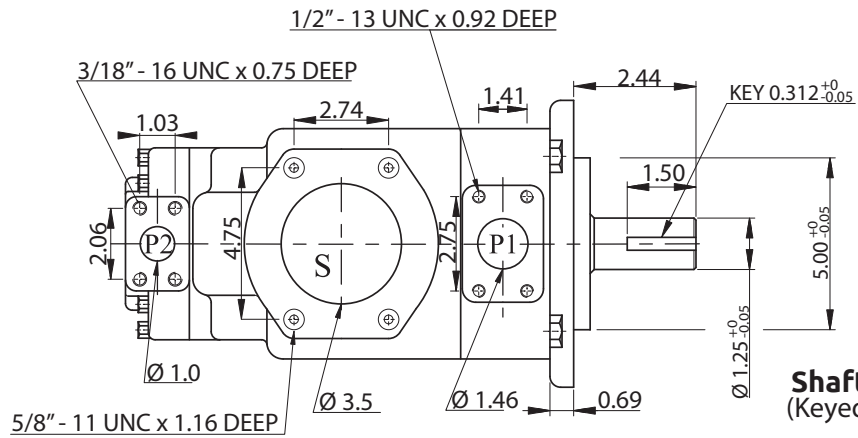

Shaft Code 2
(Keyed no SAE)

Shaft torque limits in ³ /rev x PSI (cm ³ /rev x Bar)		
Pump	Shaft	Vp x p max. P1 + P2
PT6EC	1	64044 (72306)
	2	30638 (34590)
	3	54207 (61200)
	4	67582 (76376)

PT6EC/PT6ECM OPERATING CHARACTERISTICS - TYPICAL 115 SUS (24 cSt)

Pressure Port	Series	Volumetric Displacement in ³ /rev (cm ³ /rev)	Flow Q in GPM (l/min) @ 1500 RPM			Input Power HP (KW) @ 1500 RPM			P. Max PSI (Bar)	MAX RPM
			p = 0 PSI (0 Bar)	p = 2000 PSI (140 Bar)	p = 3500 PSI (240 Bar)	p = 100 PSI (7 Bar)	p = 2000 PSI (140 Bar)	p = 3500 PSI (240 Bar)		
P1	042	8.07 (132.3)	52.44 (198.5)	49.80 (188.5)	47.89 (181.3)	6.97 (5.2)	66.25 (49.4)	110.77 (82.6)	3500 (240)	2200
	045	8.69 (142.4)	56.43 (213.6)	53.79 (203.6)	51.91 (196.5)	7.24 (5.4)	70.94 (52.9)	118.95 (88.7)		
	050	9.67 (158.5)	62.79 (237.7)	60.15 (227.7)	58.28 (220.6)	7.64 (5.7)	78.45 (58.5)	131.82 (98.3)		
	052	10.06 (164.8)	65.30 (247.2)	62.66 (237.2)	60.79 (230.1)	7.78 (5.8)	81.53 (60.8)	136.92 (102.1)		
	062	12.00 (196.7)	77.93 (295.0)	75.29 (285.0)	73.41 (277.9)	8.58 (6.4)	96.42 (71.9)	162.67 (121.3)		
	066	13.02 (213.3)	84.51 (319.9)	81.87 (309.9)	79.99 (302.8)	8.98 (6.7)	104.20 (77.7)	175.94 (131.2)		
	072	13.86 (227.1)	89.98 (340.6)	87.34 (330.6)	85.46 (323.5)	9.25 (6.9)	110.77 (82.6)	187.07 (139.5)		
	085 (1)	16.46 (269.8)	106.91 (404.7)	105.06 (397.7) (2)	()	9.79 (7.3)	87.57 (65.3) (2)	()		
P2	B/003	0.66 (10.8)	4.28 (16.2)	2.96 (11.2)	2.03 (7.7)	1.74 (1.3)	7.11 (5.3)	11.26 (8.4)	4010 (275)	2200
	B/005	1.05 (17.2)	6.82 (25.8)	5.49 (20.8)	4.57 (17.3)	1.88 (1.4)	10.06 (7.5)	16.36 (12.2)		
	B/006	1.30 (21.3)	8.43 (31.9)	7.11 (26.9)	6.18 (23.4)	2.01 (1.5)	11.94 (8.9)	19.71 (14.7)		
	B/008	1.61 (26.4)	10.46 (39.6)	9.14 (34.6)	8.22 (31.1)	2.15 (1.6)	14.35 (10.7)	23.74 (17.7)		
	B/010	2.08 (34.1)	13.50 (51.1)	12.18 (46.1)	11.25 (42.6)	2.28 (1.7)	17.97 (13.4)	29.90 (22.3)		
	B/012	2.26 (37.1)	14.69 (55.6)	13.37 (50.6)	12.44 (47.1)	2.28 (1.7)	19.31 (14.4)	32.32 (24.1)		
	B/014	2.81 (46.0)	18.23 (69.0)	16.91 (64.0)	15.98 (60.5)	2.55 (1.9)	23.60 (17.6)	39.56 (29.5)		
	B/017	3.56 (58.3)	23.09 (87.4)	21.77 (82.4)	20.84 (78.9)	2.82 (2.1)	29.37 (21.9)	49.48 (36.9)		
	B/020	3.89 (63.8)	25.28 (95.7)	23.96 (90.7)	23.04 (87.2)	2.95 (2.2)	31.92 (23.8)	53.91 (40.2)		
	B/022	4.29 (70.3)	27.84 (105.4)	26.52 (100.4)	25.60 (96.9)	3.08 (2.3)	35.00 (26.1)	59.14 (44.1)		
	B/025	4.84 (79.3)	31.41 (118.9)	30.09 (113.9)	29.16 (110.4)	3.35 (2.5)	39.16 (29.2)	66.38 (49.5)		
	B/028	5.42 (88.8)	35.19 (133.2)	33.87 (128.2)	33.23 (125.8) (3)	3.75 (2.8)	43.85 (32.7)	65.04 (48.5) (3)		
B/031	6.10 (100.0)	39.63 (150.0)	38.30 (145.0)	37.67 (142.6) (3)	3.75 (2.8)	48.95 (36.5)	72.95 (54.4) (3)			

(1) 085 = 2000 RPM max.

(1) 085 = 1305 PSI max. int.

(3) B/028 - B/031 = 3062 PSI max. int.

Min Speed : 600 RPM



PT6ED Ordering Code

PT6ED/PT6EDM - * - 066 - 038 - 1 R 00 - B 1 *

① ② P1 P2 ④ ⑤ ⑥ ⑦ ⑧ ⑨

③

- ① **Series** PT6ED/PT6EDM - SAE-C 2-Bolt Mount
- ② **Y-Metric port connection, Omit for UNC**
- ③ **Cam Ring for "P1" & "P2"**

Volumetric displacement in³/ rev (cm³/rev)
 042 = 8.07 (132.3) 062 = 12.00 (196.7)
 045 = 8.69 (142.4) 066 = 13.02 (213.3)
 050 = 9.67 (158.5) 072 = 13.86 (227.1)
 052 = 10.06 (164.8) 085 = 16.46 (269.8)

Cam Ring for "P2"

014/B14 = 2.90 (47.6) 035/B35 = 6.77 (111.0)
 017/B17 = 3.55 (58.2) 038/B38 = 7.34 (120.3)
 020/B20 = 4.03 (66.0) 042/B42 = 8.30 (136.0)
 024/B24 = 4.85 (79.5) 045/B45 = 8.89 (145.7)
 028/B28 = 5.47 (89.7) 050/B50 = 9.64 (158.0)
 031/B31 = 6.00 (98.3)

④ Type of Shaft

- 1 = Keyed (SAE CC)
- 2 = Keyed (No SAE)
- 3 = Splined (SAE C)
- 4 = Splined (SAE CC)

⑤ Rotation

(viewed from shaft end)
R = clockwise
L = counter-clockwise

⑥ Porting Combination

00=Standard

⑦ Design Letter

B = Industrial
 C = Mobile

⑧ Seal Class

- 1= S1 HNBR (for mineral oil)
- 4= S4 EPDM (for fire resistant fluids)
- 5= S5 Viton (for mineral oil and fire resistant fluids)

⑨ Modifications

Do not operate pump more than 5 seconds at any speed or viscosity if internal leakage is more than 50% of theoretical flow.

Total leakage is the sum of each section loss at its operating conditions

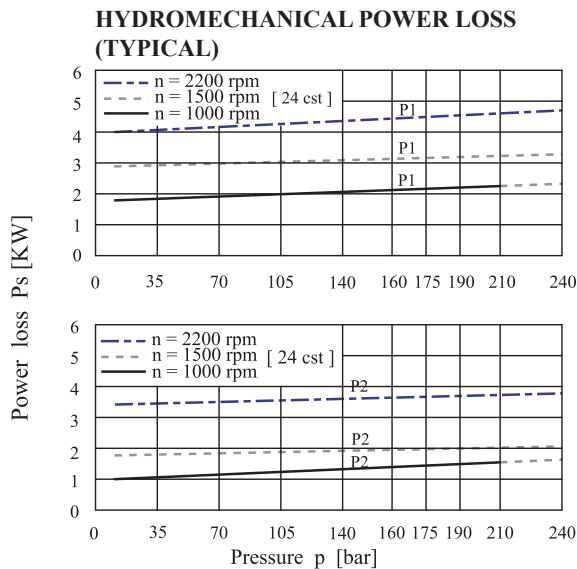
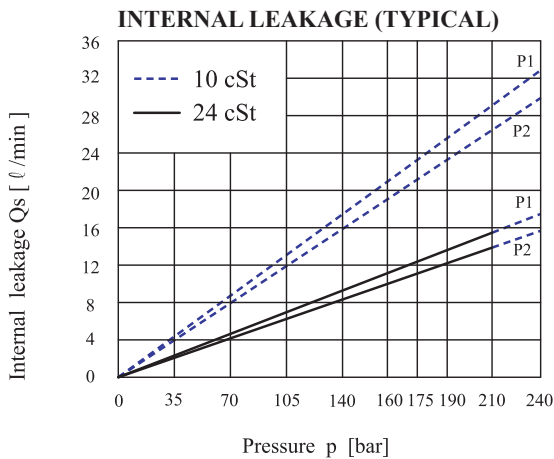

Total hydromechanical power loss is the sum of each sections loss at its operating conditions.

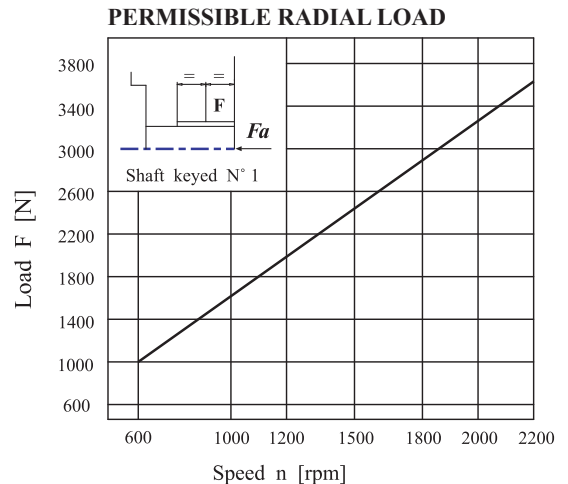

Maximum permissible axial load Fa = 2000 N



PT6ED Dimensional Drawing

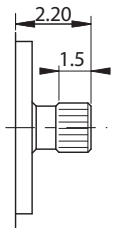
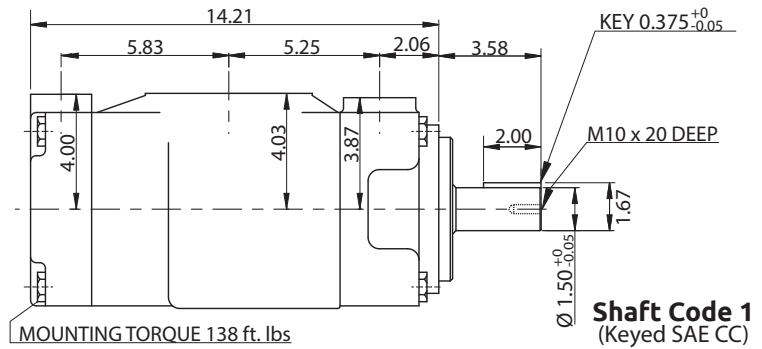
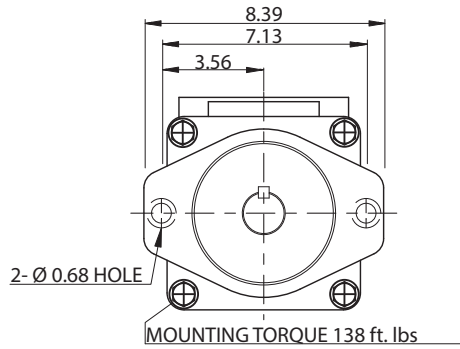

Shaft Code 3
SAE C Splined Shaft
12/24 dp. - 14 teeth
30° pressure angle
Flat root side fit.

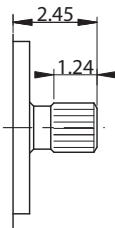

Shaft Code 4
SAE CC Splined Shaft
12/24 dp. - 17 teeth
30° pressure angle
Flat root side fit.

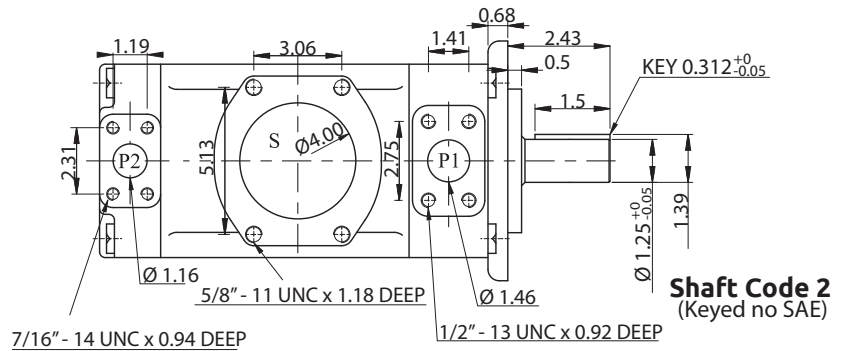

Shaft Code 2
(Keyed no SAE)
KEY 0.312+0.0/-0.05
Ø 1.25+0.0/-0.05
1.39
Ø 1.46
1/2" - 13 UNC x 0.92 DEEP
7/16" - 14 UNC x 0.94 DEEP
5/8" - 11 UNC x 1.18 DEEP

Shaft torque limits in ³ /rev x PSI (cm ³ /rev x Bar)		
Pump	Shaft	Vp x p max. P1 + P2
PT6ED	1	64044 (72306)
	2	30638 (34590)
	3	54207 (61200)
	4	67582 (76376)

PT6ED/PT6EDM OPERATING CHARACTERISTICS - TYPICAL 115 SUS (24 cSt)

Pressure Port	Series	Volumetric Displacement in ³ /rev (cm ³ /rev)	Flow Q in GPM (l/min) @ 1500 RPM			Input Power HP (KW) @ 1500 RPM			P. Max PSI (Bar)	MAX RPM
			p = 0 PSI (0 Bar)	p = 2000 PSI (140 Bar)	p = 3500 PSI (240 Bar)	p = 100 PSI (7 Bar)	p = 2000 PSI (140 Bar)	p = 3500 PSI (240 Bar)		
P1	042	8.07 (132.3)	52.44 (198.5)	49.80 (188.5)	47.89 (181.3)	6.97 (5.2)	66.25 (49.4)	110.77 (82.6)	3500 (240)	2200
	045	8.69 (142.4)	56.43 (213.6)	53.79 (203.6)	51.91 (196.5)	7.24 (5.4)	70.94 (52.9)	118.95 (88.7)		
	050	9.67 (158.5)	62.79 (237.7)	60.15 (227.7)	58.28 (220.6)	7.64 (5.7)	78.45 (58.5)	131.82 (98.3)		
	052	10.06 (164.8)	65.30 (247.2)	62.66 (237.2)	60.79 (230.1)	7.78 (5.8)	81.53 (60.8)	136.92 (102.1)		
	062	12.00 (196.7)	77.93 (295.0)	75.29 (285.0)	73.41 (277.9)	8.58 (6.4)	96.42 (71.9)	162.67 (121.3)		
	066	13.02 (213.3)	84.51 (319.9)	81.87 (309.9)	79.99 (302.8)	8.98 (6.7)	104.20 (77.7)	175.94 (131.2)		
	072	13.86 (227.1)	89.98 (340.6)	87.34 (330.6)	85.46 (323.5)	9.25 (6.9)	110.77 (82.6)	187.07 (139.5)		
	085 (1)	16.46 (269.8)	106.91 (404.7)	105.06 (397.7 (2)	()	9.79 (7.3)	87.57 (65.3 (2)	()		
P2	B/014	2.90 (47.6)	18.86 (71.4)	16.41 (62.1)	14.77 (55.9)	3.08 (2.3)	24.81 (18.5)	41.04 (30.6)	3500 (240)	2200
	B/017	3.55 (58.2)	23.06 (87.3)	20.61 (78.0)	18.97 (71.8)	3.35 (2.5)	29.77 (22.2)	49.62 (37.0)		
	B/020	4.03 (66.0)	26.15 (99.0)	23.70 (89.7)	22.06 (83.5)	3.75 (2.8)	33.39 (24.9)	55.92 (41.7)		
	B/024	4.85 (79.5)	31.52 (119.3)	29.06 (110.0)	27.42 (103.8)	4.02 (3.0)	39.69 (29.6)	66.78 (49.8)		
	B/028	5.47 (89.7)	35.53 (134.5)	33.07 (125.2)	31.44 (119.0)	4.29 (3.2)	44.52 (33.2)	74.96 (55.9)		
	B/031	6.00 (98.3)	38.97 (147.5)	36.48 (138.1)	34.84 (131.9)	4.43 (3.3)	48.54 (36.2)	81.80 (61.0)		
	B/035	6.77 (111.0)	43.98 (166.5)	41.53 (157.2)	39.89 (151.0)	4.69 (3.5)	54.58 (40.7)	92.13 (68.7)		
	B/038	7.34 (120.3)	47.66 (180.4)	45.20 (171.1)	43.56 (164.9)	4.96 (3.7)	58.87 (43.9)	99.64 (74.3)		
	B/042	8.30 (136.0)	53.89 (204.0)	51.43 (194.7)	49.80 (188.5)	5.36 (4.0)	66.25 (49.4)	112.24 (83.7)		
	B/045	8.89 (145.7)	57.72 (218.5)	55.26 (209.2)	53.63 (203.0)	5.50 (4.1)	70.81 (52.8)	120.02 (89.5)		
B/050	9.64 (158.0)	62.61 (237.0)	60.15 (227.7)	59.17 (224.0 (3)	5.90 (4.4)	76.44 (57.0)	113.99 (85.0 (3)			

(1) 085 = 2000 RPM max.

(1) 085 = 1305 PSI max. int.

(3) B/050 = 3062 PSI max. int.

Min Speed : 600 RPM

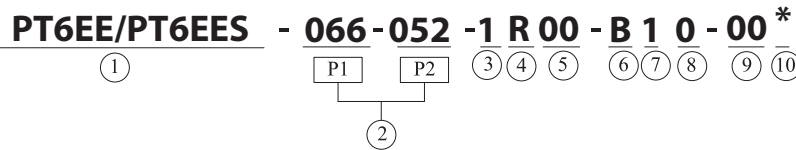

① **Series** PT6EE - ISO 250 B4HW 4 Bolt Mount
3019-2 Flange
PT6EES - SAE-E 4 Bolt Mount
J744c Flange

② **Cam Ring for "P1" & "P2"**
Volumetric displacement in in^3/rev (cm^3/rev)

042 = 8.07 (132.3)	062 = 12.00 (196.7)
045 = 8.69 (142.4)	066 = 13.02 (213.3)
050 = 9.67 (158.5)	072 = 13.86 (227.1)
052 = 10.06 (164.8)	085 = 16.46 (269.8)

③ **Type of Shaft**
1 = Keyed (SAE CC)
2 = Keyed (G45N 3019-2)
3 = Splined (SAE CC)
4 = Splined (SAE D&E)
5 = Keyed (SAE D&E)

④ **Rotation**
(viewed from shaft end)
R = clockwise
L = counter-clockwise

⑤ **Porting Combination**
00=Standard

⑥ **Design Letter**

⑦ **Seal Class**
1= S1 HNBR (for mineral oil)
4= S4 EPDM (for fire resistant fluids)
5= S5 Viton (for mineral oil and fire resistant fluids)

⑧ **Coupling Adapter**
0 = None
2 = SAE B
3 = SAE BB

⑨ **Port Connection Variables**
SAE 4 bolt flange (J518c)

	Unc	Metric
PT6EE		M0
PT6EES	00	M0

⑩ **Modifications**

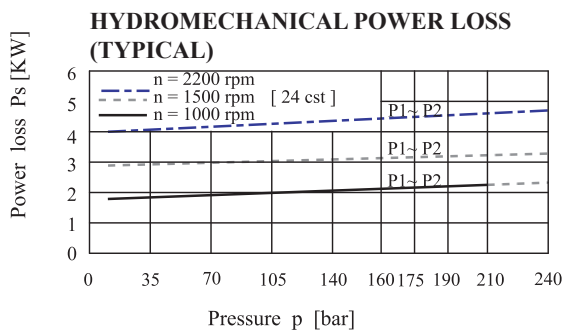
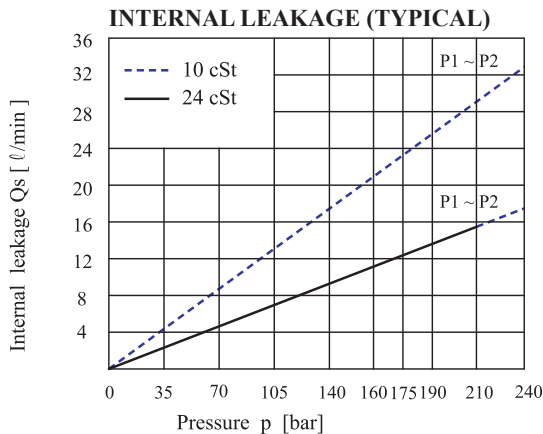

Total hydromechanical power loss is the sum of each sections loss at its operating conditions.

Do not operate pump more than 5 seconds at any speed or viscosity if internal leakage is more than 50% of theoretical flow.

Total leakage is the sum of each section loss at its operating conditions

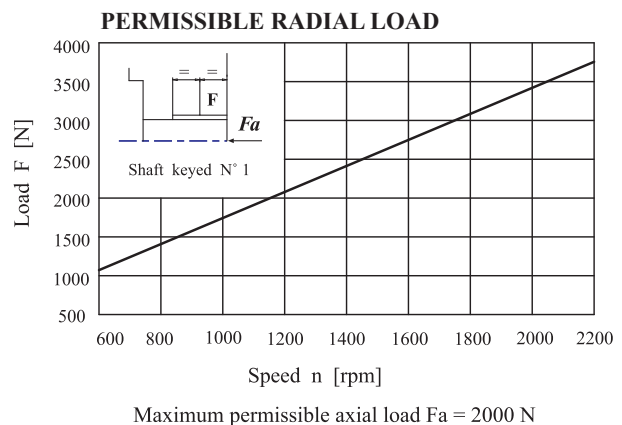



PT6EE/PT6EES Dimensional Drawing

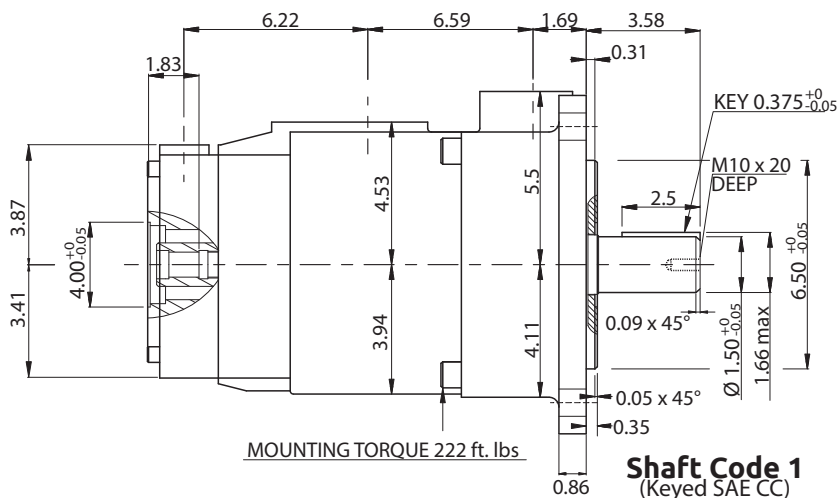
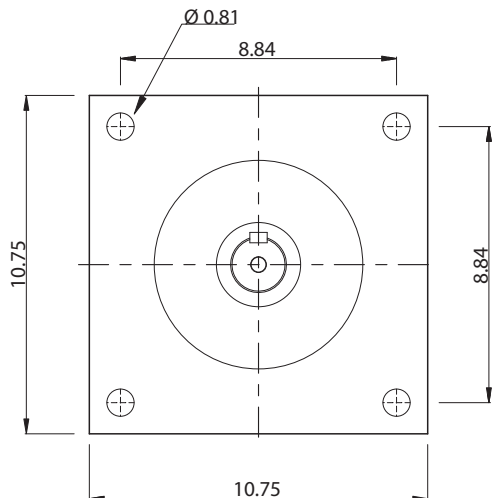

Shaft torque limits in ³ /rev x PSI (cm ³ /rev x Bar)			
Shaft	Vi x p max.	Coupling	Vi x p max.
1	80053 (90380)	SAE-B	18246 (20600)
2	101506 (114600)	SAE-BB	28937 (32670)
3	112312 (126800)		
4	112312 (126800)		
5	104818 (110840)		

Shaft	Coupling Adapter
0	without coupling
2	SAE B - 13 teeth - pitch 16/32 Major dia.(min) 0.875 Minor dia.(min) 0.753
3	SAE BB - 15 teeth - pitch 16/32 Major dia.(min) 1.00 Minor dia.(min) 0.87

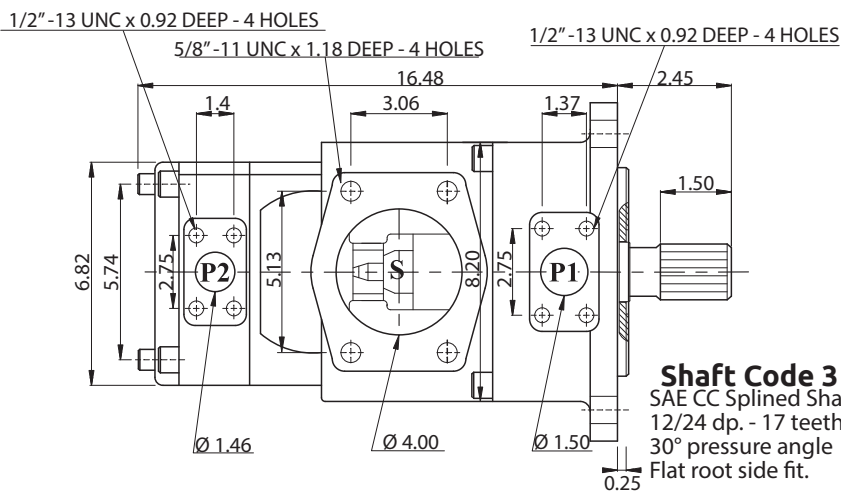

PT6EE

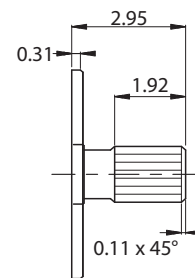
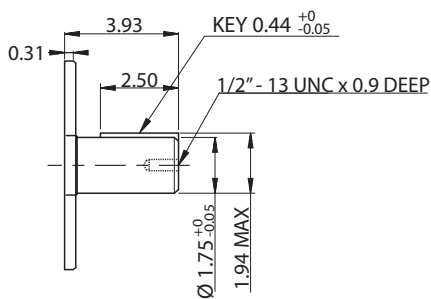
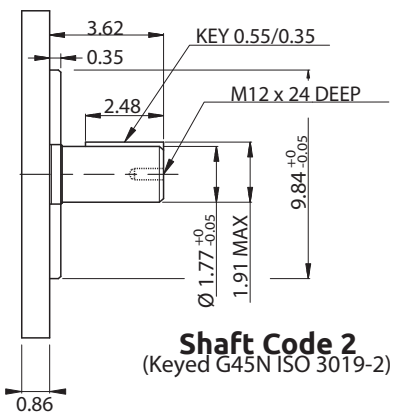

PT6EE OPERATING CHARACTERISTICS - TYPICAL 115 SUS (24 cSt)

Pressure Port	Series	Volumetric Displacement in ³ /rev (cm ³ /rev)	Flow Q IN GPM (l/min) @ 1500 RPM			Input Power HP (KW) @ 1500 RPM			P. Max PSI (Bar)	MAX RPM
			p = 0 PSI (0 Bar)	p = 2000 PSI (140 Bar)	p = 3500 PSI (240 Bar)	p = 100 PSI (7 Bar)	p = 2000 PSI (140 Bar)	p = 3500 PSI (240 Bar)		
P1 & P2	042	8.07 (132.3)	52.44 (198.5)	49.80 (188.5)	47.89 (181.3)	6.97 (5.2)	66.25 (49.4)	110.77 (82.6)	3500 (240)	2200
	045	8.69 (142.4)	56.43 (213.6)	53.79 (203.6)	51.91 (196.5)	7.24 (5.4)	70.94 (52.9)	118.95 (88.7)		
	052	10.06 (164.8)	65.30 (247.2)	62.66 (237.2)	60.79 (230.1)	7.78 (5.8)	81.53 (60.8)	136.92 (102.1)		
	062	12.00 (196.7)	77.93 (295.0)	75.29 (285.0)	73.41 (277.9)	8.58 (6.4)	96.42 (71.9)	162.67 (121.3)		
	066	13.02 (213.3)	84.51 (319.9)	81.87 (309.9)	79.99 (302.8)	8.98 (6.7)	104.20 (77.7)	175.94 (131.2)		
	072	13.86 (227.1)	89.98 (340.6)	87.34 (330.6)	85.46 (323.5)	9.25 (6.9)	110.77 (82.6)	187.07 (139.5)		
	085 ⁽¹⁾	16.46 (269.8)	106.91 (404.7)	105.06 (397.2)	()	9.79 (7.3)	87.57 (65.3)	()	1450 (100)	2000

(1) 085 = 2000 rpm max.

(2) 085 = 1087 PSI max. int. 085 = 1305 PSI max. int.

Min Speed : 600 RPM

PT6GCC - B22 - B08 -6 R 00 - A 1 - 00 *

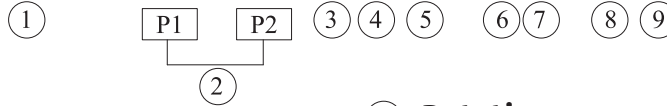

1 Series

2 Cam Ring for "P1" & "P2"

Volumetric displacement in³/rev (cm³/rev)

B03 = 0.66 (10.8)	B17 = 3.56 (58.3)
B05 = 1.05 (17.2)	B20 = 3.89 (63.8)
B06 = 1.30 (21.3)	B22 = 4.29 (70.3)
B08 = 1.61 (26.4)	B25 = 4.84 (79.3)
B10 = 2.08 (34.1)	B28 = 5.42 (88.8)
B12 = 2.26 (37.1)	B31 = 6.10 (100.0)
B14 = 2.81 (46.0)	

Cam Ring for "P2"

B03 = 0.66 (10.8)	B17 = 3.56 (58.3)
B05 = 1.05 (17.2)	B20 = 3.89 (63.8)
B06 = 1.30 (21.3)	B22 = 4.29 (70.3)
B08 = 1.61 (26.4)	B25 = 4.84 (79.3)
B10 = 2.08 (34.1)	B28 = 5.42 (88.8)
B12 = 2.26 (37.1)	B31 = 6.10 (100.0)
B14 = 2.81 (46.0)	

3 Type of Shaft

6 = splined (DIN 5462)

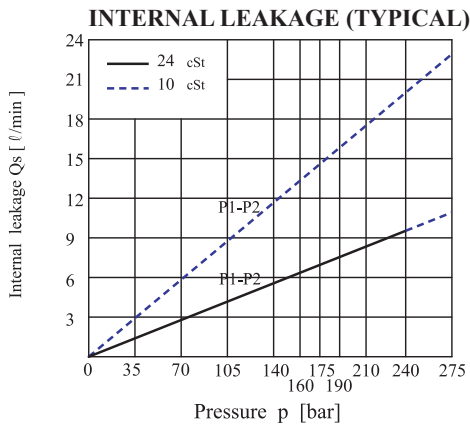

HYDROMECHANICAL POWER LOSS (TYPICAL)

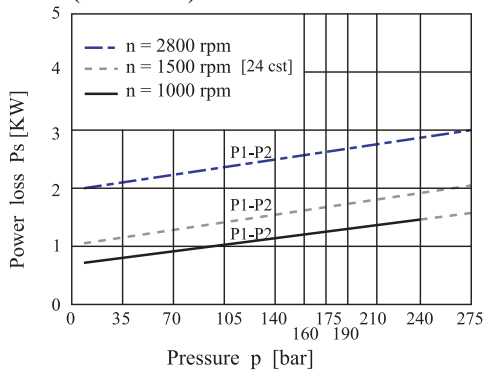

Total hydromechanical power loss is the sum of each sections loss at its operating conditions.

4 Rotation (viewed from shaft end)

R = clockwise
L = counter-clockwise

5 Porting Combination

00 = Standard

6 Design Letter

7 Seal Class

1 = S1 HNBR (for mineral oil)
4 = S4 EPDM (for fire resistant fluids)
5 = S5 Viton (for mineral oil and fire resistant fluids)

8 Mounting W/connection variables

		P1 = 1", S = 3"		P1 = 1", S = 2 1/2" 2)	
P2		1"	3/4" 1)	1"	3/4" 1)
Code	Unc	00	01	10	11
	Metric	0M	M0	1M	M1

1) for 2.80 in³/rev (46 cm³/rev) max.

2) for 7.69 in³/rev (126 cm³/rev) max.

The large cartridge must be always mounted in the front.

9 Modifications

Do not operate pump more than 5 seconds at any speed or viscosity if internal leakage is more than 50% of theoretical flow.

Total leakage is the sum of each section loss at its operating conditions

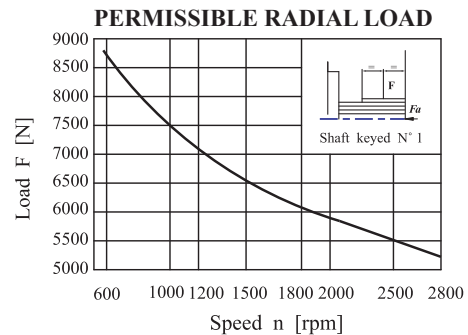

Life time 3000 hours when 70% of the time at 500 N and 30% at max. load



PT6GCC Dimensional Drawing

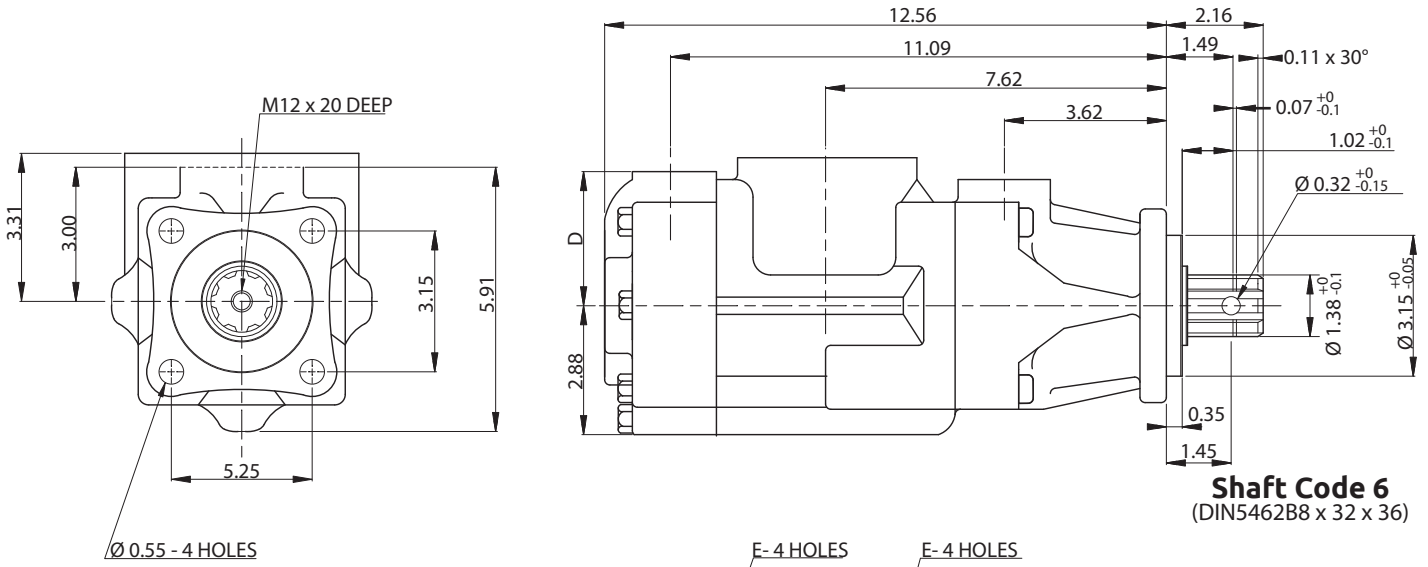

Shaft Code 6
(DIN5462B8 x 32 x 36)

PORT	A	B	C	D	E
S	4.19	2.44	3.00		5/8"-11 UNC x 1.12 (M16 x 28.4 DEEP)
S	3.50	1.97	2.50		1/2"-13 UNC x 0.94 (M12 x 24.0 DEEP)
P2	1.88	0.87	0.74	3.00	3/8"-16 UNC x 0.75 (M10 x 19.0 DEEP)
P2	2.06	1.03	1.00	2.94	

Shaft torque limits in ³ /rev x PSI (cm ³ /rev x Bar)	
Shaft	Vp x p max. P1 + P2
6	36921 (32670)

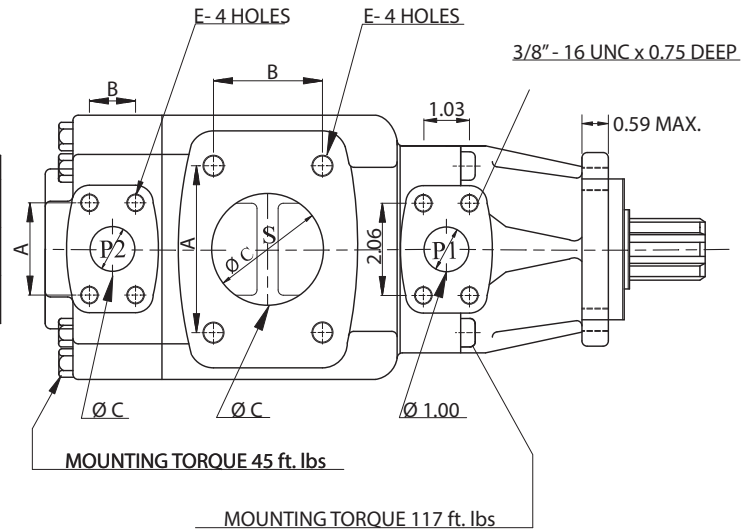

PT6GCC OPERATING CHARACTERISTICS - TYPICAL 115 SUS (24 cst)

Pressure Port	Series	Volumetric Displacement in ³ /rev (cm ³ /rev)	Flow Q in GPM (l/min) @ 1500 RPM			Input Power HP (KW) @ 1500 RPM			P. Max PSI (Bar)	MAX RPM
			p = 0 PSI (0 Bar)	p = 2000 PSI (140 Bar)	p = 3500 PSI (240 Bar)	p = 100 PSI (7 Bar)	p = 2000 PSI (140 Bar)	p = 3500 PSI (240 Bar)		
P1 & P2	B03	0.66 (10.8)	4.28 (16.2)	2.83 (10.7)	(----)	1.74 (1.3)	7.11 (5.3)	(----)	4010 (275)	2800
	B05	1.05 (17.2)	6.82 (25.8)	5.36 (20.3)	4.17 (15.8)	1.88 (1.4)	10.06 (7.5)	16.36 (12.2)		
	B06	1.30 (21.3)	8.43 (31.9)	7.00 (26.5)	5.81 (22.0)	2.01 (1.5)	11.94 (8.9)	19.71 (14.7)		
	B08	1.61 (26.4)	10.46 (39.6)	9.01 (34.1)	7.82 (29.6)	2.15 (1.6)	14.35 (10.7)	23.74 (17.7)		
	B10	2.08 (34.1)	13.50 (51.1)	12.07 (45.7)	10.88 (41.2)	2.28 (1.7)	17.97 (13.4)	29.90 (22.3)		
	B12	2.26 (37.1)	14.69 (55.6)	13.26 (50.2)	12.07 (45.7)	2.28 (1.7)	19.31 (14.4)	32.32 (24.1)		
	B14	2.81 (46.0)	18.23 (69.0)	16.77 (63.5)	15.59 (59.0)	2.55 (1.9)	23.60 (17.6)	39.56 (29.5)		
	B17	3.56 (58.3)	23.09 (87.4)	21.66 (82.0)	20.47 (77.5)	2.82 (2.1)	29.37 (21.9)	49.48 (36.9)		
	B20	3.89 (63.8)	25.28 (95.7)	23.83 (90.2)	22.64 (85.7)	2.95 (2.2)	31.92 (23.8)	53.91 (40.2)		
	B22	4.29 (70.3)	27.84 (105.4)	26.42 (100.0)	25.23 (95.5)	3.08 (2.3)	35.00 (26.1)	59.14 (44.1)		
	B25 ₍₁₎	4.84 (79.3)	31.41 (118.9)	29.98 (113.5)	28.79 (109.0)	3.35 (2.5)	39.16 (29.2)	66.38 (49.5)		
	B28 ₍₁₎	5.42 (88.8)	35.19 (133.2)	33.73 (127.7)	32.89 (124.5 (2)	3.75 (2.8)	43.85 (32.7)	65.04 (48.5 (2)	3062 (210)	2500
B31 ₍₁₎	6.10 (100.0)	39.63 (150.0)	38.17 (144.5)	37.33 (141.3 (2)	3.75 (2.8)	48.95 (36.5)	72.95 (54.4 (2)			

(1) B25 - B28 - B31= 2500 rpm max.

(2) B28 - B31 = 3062 PSI max. int.

Min Speed : 600 RPM

-- Do not use because internal leakage greater than 50% theoretical flow.

PT6QDC - 038 - 022 - 1 R 00 - A 1 - 00 *



① Series PT6QDC-SAE-C 2 & 4 Bolt Mount

② Cam Ring for "P1"

Volumetric displacement in³/ rev (cm³/rev)

014 = 2.90 (47.6)	035 = 6.77 (111.0)
017 = 3.55 (58.2)	038 = 7.34 (120.3)
020 = 4.03 (66.0)	042 = 8.30 (136.0)
024 = 4.85 (79.5)	045 = 8.89 (145.7)
028 = 5.47 (89.7)	050 = 9.64 (158.0)
031 = 6.00 (98.3)	

Cam Ring for "P2"

003 = 0.66 (10.8)	017 = 3.56 (58.2)
005 = 1.00 (16.3)	020 = 4.03 (66.0)
006 = 1.30 (21.3)	022 = 4.29 (70.5)
008 = 1.61 (26.4)	025 = 4.84 (79.3)
010 = 1.92 (31.1)	028 = 5.47 (89.7)
012 = 2.26 (37.1)	031 = 6.00 (98.3)
014 = 2.81 (46.0)	

REPLACEMENT UNITS NOT AVAILABLE PRIOR TO PRINT

④ Rotation (viewed from shaft end)

R = clockwise
L = counter-clockwise

⑤ Porting Combination
00=Standard

⑥ Design Letter

⑦ Seal Class

- 1= S1 HNBR (for mineral oil)
- 4= S4 EPDM (for fire resistant fluids)
- 5= S5 Viton (for mineral oil and fire resistant fluids)

⑧ Mounting W/connection variables

	00	01	M0	M1
P2	1"	3/4"	1"	3/4"

⑨ Modifications

③ Type of Shaft

- 1 = Keyed (SAE C)
- 2 = Keyed (No SAE)
- 3 = Splined (SAE C)
- 4 = Splined (No SAE)

HYDROMECHANICAL POWER LOSS (TYPICAL)

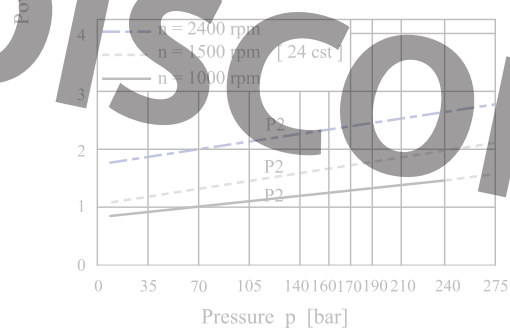

INTERNAL LEAKAGE (TYPICAL)

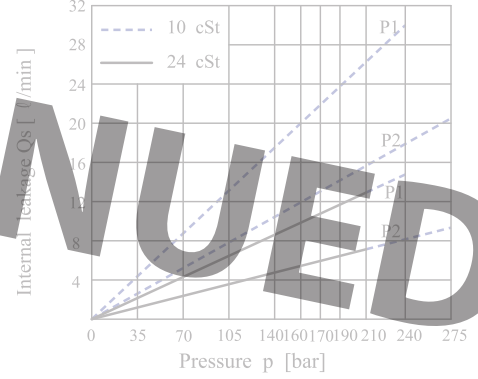

PLEASE CALL CUSTOMER SERVICE FOR REPLACEMENT UNIT

PERMISSIBLE RADIAL LOAD

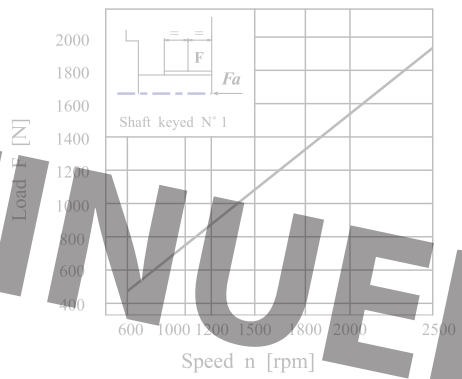

Maximum permissible axial load Fa = 1200 N



PT6QDC Dimensional Drawing

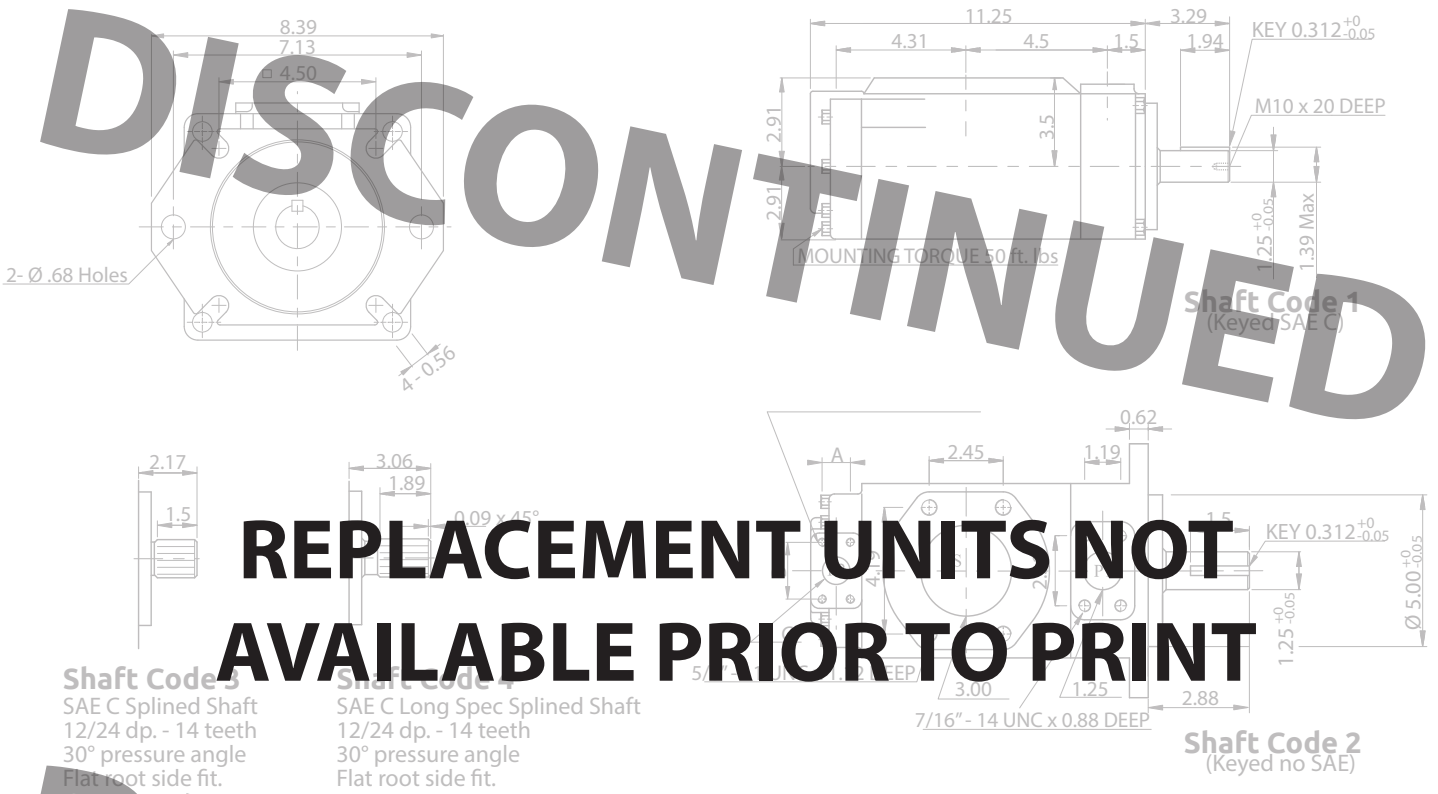

Shaft torque limits in ³ /rev x PSI (cm ³ /rev x Bar)		
Pump	Shaft	Vp x p max. P1 + P2
PT6DC	1	38299 (43240)
	2	30638 (34590)
	3	54207 (61200)
	4	54207 (61200)
	5	49247 (55600)

	Alternate Connect. Variables	
	00 & M0	01 & M1
A	1.03	0.87
B	2.06	1.87
C	1.00	0.75

PT6QDC OPERATING CHARACTERISTICS - TYPICAL 115 SUS (24 cSt)

Pressure Port	Series	Volumetric Displacement in ³ /rev (cm ³ /rev)	Flow Q in GPM (l/min) @ 1500 RPM			Input Power HP (KW) @ 1500 RPM			P. Max PSI (Bar)	MAX RPM
			p = 0 PSI (0 Bar)	p = 2000 PSI (140 Bar)	p = 3500 PSI (240 Bar)	p = 100 PSI (7 Bar)	p = 2000 PSI (140 Bar)	p = 3500 PSI (240 Bar)		
P1	014	2.90 (47.6)	18.86 (71.4)	16.41 (62.1)	14.77 (55.9)	3.08 (2.3)	24.81 (18.5)	41.04 (30.6)	3500 (240)	2500
	017	3.55 (58.2)	23.06 (87.3)	20.61 (78.0)	18.97 (71.8)	3.35 (2.5)	29.77 (22.2)	49.62 (37.0)		
	028	5.47 (89.7)	35.53 (134.5)	33.07 (125.2)	31.44 (119.0)	4.29 (3.2)	44.52 (33.2)	74.96 (55.9)		
	031	6.00 (98.3)	38.97 (147.5)	36.48 (138.1)	34.84 (131.9)	4.43 (3.3)	48.54 (36.2)	81.80 (61.0)		
	035	6.77 (110.0)	43.99 (166.6)	41.50 (156.2)	39.88 (149.8)	4.78 (3.6)	52.58 (39.4)	88.75 (68.7)		
	038	7.34 (120.3)	47.96 (180.5)	45.47 (171.1)	43.45 (163.9)	5.07 (3.8)	56.61 (42.3)	95.74 (74.3)		
	042 (1)	8.30 (136.0)	53.89 (204.0)	51.43 (194.7)	49.80 (188.5)	5.36 (4.0)	66.25 (49.4)	112.24 (83.7)		
	045 (1)	8.89 (145.7)	57.72 (218.5)	55.26 (209.2)	53.63 (203.0)	5.50 (4.1)	70.81 (52.8)	120.02 (89.5)		
	050 (1)	9.64 (158.0)	62.61 (237.0)	60.15 (227.7)	59.17 (224.0 (2))	5.90 (4.4)	76.44 (57.0)	113.99 (85.0 (2))		
	P2	003	0.66 (10.8)	4.28 (16.2)	2.96 (11.2)	2.03 (7.7)	1.74 (1.3)	7.11 (5.3)		
005		1.05 (17.2)	6.82 (25.8)	5.49 (20.8)	4.57 (17.3)	1.88 (1.4)	10.06 (7.5)	16.36 (12.2)		
006		1.30 (21.3)	8.43 (31.9)	7.11 (26.9)	6.18 (23.4)	2.01 (1.5)	11.94 (8.9)	19.71 (14.7)		
008		1.61 (26.4)	10.46 (39.6)	9.14 (34.6)	8.22 (31.1)	2.15 (1.6)	14.35 (10.7)	23.74 (17.7)		
010		2.08 (34.1)	13.50 (51.1)	12.18 (46.1)	11.25 (42.6)	2.28 (1.7)	17.97 (13.4)	29.90 (22.3)		
012		2.26 (37.1)	14.69 (55.6)	13.37 (50.6)	12.44 (47.1)	2.28 (1.7)	19.31 (14.4)	32.32 (24.1)		
014		2.81 (46.0)	18.23 (69.0)	16.91 (64.0)	15.98 (60.5)	2.55 (1.9)	23.60 (17.6)	39.56 (29.5)		
017		3.56 (58.3)	23.09 (87.4)	21.77 (82.4)	20.84 (78.9)	2.82 (2.1)	29.37 (21.9)	49.48 (36.9)		
020		3.89 (63.8)	25.28 (95.7)	23.96 (90.7)	23.04 (87.2)	2.95 (2.2)	31.92 (23.8)	53.91 (40.2)		
022		4.29 (70.3)	27.84 (105.4)	26.52 (100.4)	25.60 (96.9)	3.08 (2.3)	35.00 (26.1)	59.14 (44.1)		
025		4.84 (79.3)	31.41 (118.9)	30.09 (113.9)	29.16 (110.4)	3.35 (2.5)	39.15 (29.2)	66.38 (49.5)		
028		5.42 (88.8)	35.19 (133.2)	33.87 (128.2)	33.23 (125.8 (2))	3.75 (2.8)	43.85 (32.7)	65.04 (48.5 (2))		
031	6.10 (100.0)	39.63 (150.0)	38.30 (145.0)	37.67 (142.6 (2))	3.75 (2.8)	48.95 (36.5)	72.95 (54.4 (2))			

(1) 042-045-050 = 2200 RPM max.

(2) 028-031-050 = 3062 PSI max. int.

Min Speed : 600 RPM

PT67CB **W** - **022** - **B08** - **6** **R** **00** - **A** **1** - **00** *

① ② P1 P2 ④ ⑤ ⑥ ⑦ ⑧ ⑨ ⑩

① **Series** PT67CB - SAE-B 2-Bolt Mount

② **Use for Severe duty shaft only**

③ **Cam Ring for "P1"**

Volumetric displacement in³/ rev (cm³/rev)

003 = 0.66 (10.8)	017 = 3.56 (58.3)
005 = 1.05 (17.2)	020 = 3.89 (63.8)
006 = 1.30 (21.3)	022 = 4.29 (70.3)
008 = 1.61 (26.4)	025 = 4.84 (79.3)
010 = 2.08 (34.1)	028 = 5.42 (88.8)
012 = 2.26 (37.1)	031 = 6.10 (100.0)
014 = 2.81 (46.0)	

Cam Ring for "P2"

B02 = 0.35 (5.7)	B09 = 1.71 (28.0)
B03 = 0.60 (9.8)	B10 = 1.94 (31.8)
B04 = 0.78 (12.8)	B11 = 2.13 (34.9)
B05 = 0.97 (15.9)	B12 = 2.50 (40.9)
B06 = 1.21 (19.8)	B14 = 2.75 (45.1)
B07 = 1.37 (22.5)	B15 = 3.05 (50.0)
B08 = 1.52 (24.9)	

④ **Type of Shaft**

- 1 = Keyed (No SAE)
 - 3 = Splined (SAE BB)
 - 5 = Splined (SAE B)
- W version**
- 2 = Keyed (SAE BB)

HYDROMECHANICAL POWER LOSS (TYPICAL)

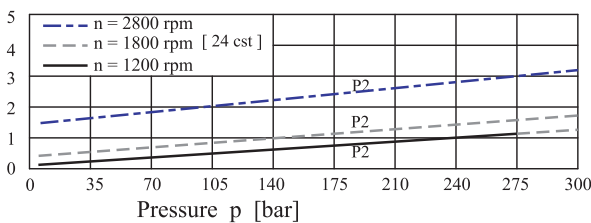
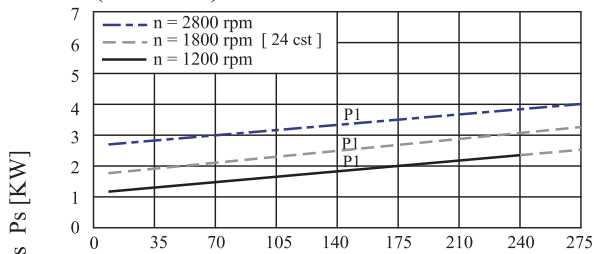

Do not operate pump more than 5 seconds at any speed or viscosity if internal leakage is more than 50% of theoretical flow.

Total leakage is the sum of each section loss at its operating conditions

⑤ **Rotation**
(viewed from shaft end)
R= clockwise
L= counter-clockwise

⑥ **Porting Combination**
00=Standard

⑦ **Design Letter**

⑧ **Seal Class**
1= S1 HNBR (for mineral oil)
4= S4 EPDM (for fire resistant fluids)
5= S5 Viton (for mineral oil and fire resistant fluids)

⑨ **Mounting W/connection variables**

P1 = 1" , P2 = 3/4" , S = 2 1/2"	
Unc	Metric
11	M1

⑩ **Modifications**

INTERNAL LEAKAGE (TYPICAL)

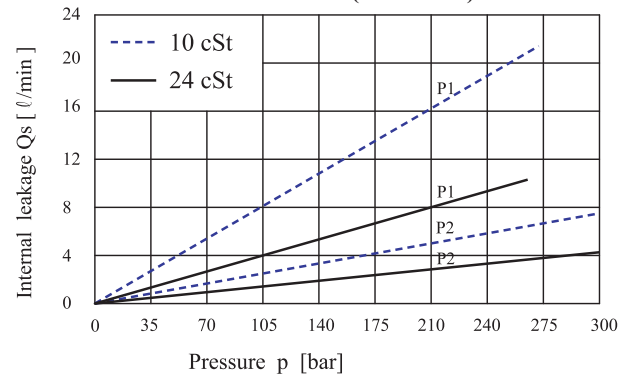

PERMISSIBLE RADIAL LOAD

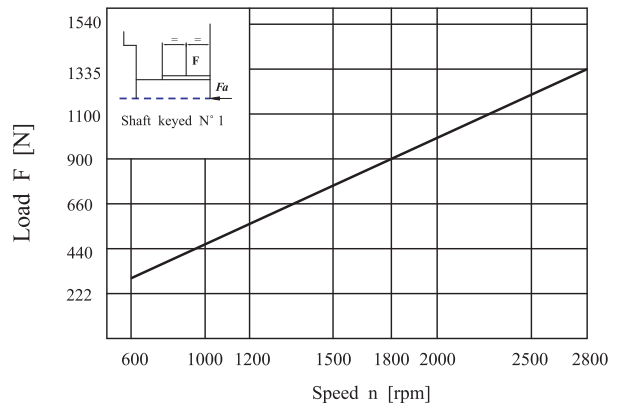

Maximum permissible axial load Fa = 800 N



PT67CB Dimensional Drawing

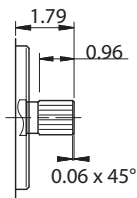
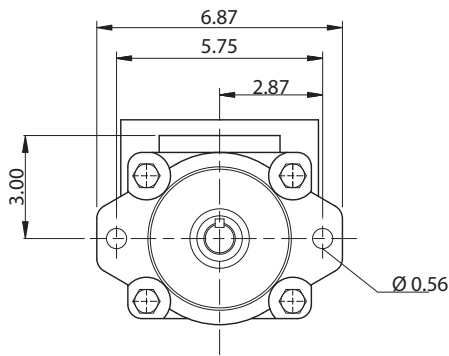

Shaft Code 3
SAE BB Splined Shaft
16/32 dp. - 15 teeth
30° pressure angle
Flat root side fit.

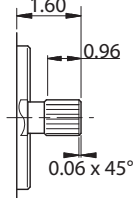

Shaft Code 4
SAE B Splined Shaft
16/32 dp. - 13 teeth
30° pressure angle
Flat root side fit.

Shaft torque limits in ³ /rev x PSI (cm ³ /rev x Bar)		
Pump	Shaft	Vp x p max. P1 + P2
PT6CD	1	12666 (14300)
	2	18972 (21420)
	3	28937 (32670)
	5	18246 (20600)

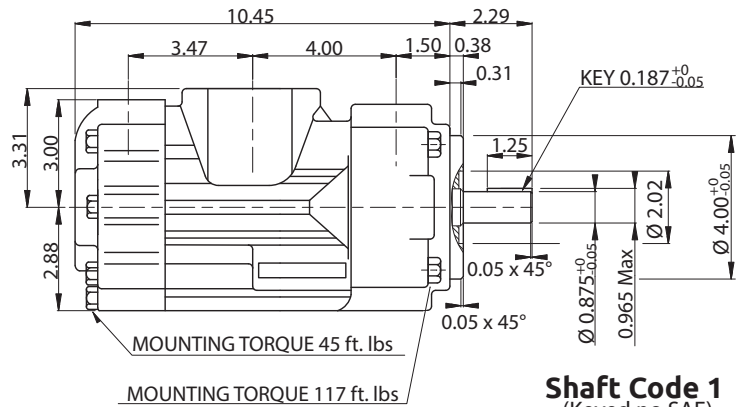

Shaft Code 1
(Keyed no SAE)

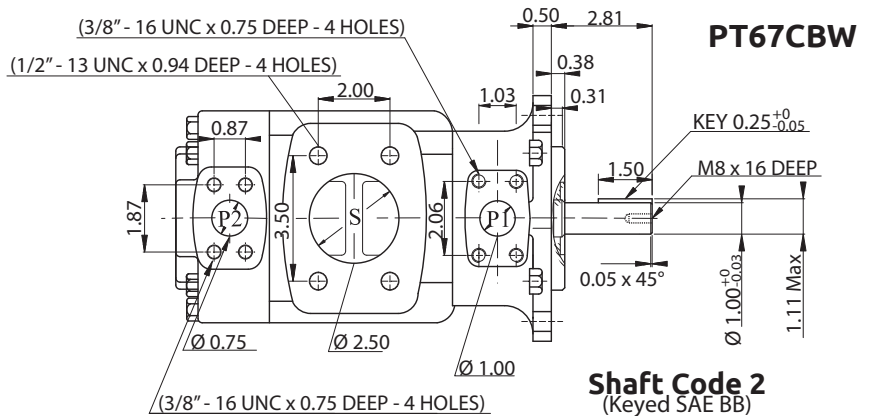

Shaft Code 2
(Keyed SAE BB)

PT67CB OPERATING CHARACTERISTICS - TYPICAL 115 Sus (24 cSt)

Pressure Port	Series	Volumetric Displacement in ³ /rev (cm ³ /rev)	Flow Q in GPM (l/min) @ 1800 RPM			Input Power HP (KW) @ 1800 RPM			P. Max PSI (Bar)	MAX RPM
			p = 0 PSI (0 Bar)	p = 2000 PSI (140 Bar)	p = 4000 PSI (275 Bar)	p = 100 PSI (7 Bar)	p = 2000 PSI (140 Bar)	p = 4000 PSI (275 Bar)		
P1	003	0.66 (10.8)	5.18 (19.6)	3.86 (14.6)	0.00 (--)	2.11 (1.57)	8.45 (6.30)	0.00 (--)	4000 (275)	2800
	005	1.05 (17.2)	8.16 (30.9)	6.87 (26.0)	5.68 (21.5)	2.28 (1.70)	11.99 (8.94)	19.81 (14.77)		
	006	1.30 (21.3)	10.12 (38.3)	8.82 (33.4)	7.61 (28.8)	2.39 (1.78)	14.27 (10.64)	23.79 (17.74)		
	008	1.61 (26.4)	12.52 (47.4)	11.25 (42.6)	10.01 (37.9)	2.53 (1.89)	17.10 (12.75)	28.74 (21.43)		
	010	2.08 (34.1)	16.19 (61.3)	14.90 (56.4)	13.68 (51.8)	2.76 (2.06)	21.38 (15.94)	36.21 (27.00)		
	012	2.26 (37.1)	17.62 (66.7)	16.33 (61.8)	15.11 (57.2)	2.83 (2.11)	23.04 (17.18)	39.13 (29.18)		
	014	2.81 (46.0)	21.85 (82.7)	20.55 (77.8)	19.34 (73.2)	3.08 (2.30)	27.99 (20.87)	47.77 (35.62)		
	017	3.56 (58.3)	27.69 (104.8)	26.39 (99.9)	25.18 (95.3)	3.42 (2.55)	34.80 (25.95)	59.73 (44.54)		
	020	3.89 (63.8)	30.30 (114.7)	29.01 (109.8)	27.79 (105.2)	3.57 (2.66)	37.86 (28.23)	65.07 (48.52)		
	022	4.29 (70.3)	33.39 (126.4)	32.10 (121.5)	30.88 (116.9)	3.75 (2.80)	41.46 (30.92)	71.37 (53.22)		
	025 (1)	4.84 (79.3)	37.64 (142.5)	36.35 (137.6)	35.16 (133.1)	4.01 (2.99)	46.45 (34.64)	80.11 (59.74)		
028 (1)	5.42 (88.8)	42.16 (159.6)	40.87 (154.7)	40.74 (154.2 (2)	4.26 (3.18)	51.74 (38.58)	76.73 (57.22 (2)			
031 (1)	6.10 (100.0)	47.47 (179.7)	46.20 (174.9)	45.57 (172.5 (2)	4.57 (3.41)	57.95 (43.21)	86.05 (64.17 (2)			
P2	Series	in ³ /rev (cm ³ /rev)	p = 0 PSI (0 Bar)	p = 2000 PSI (140 Bar)	p = 4375 PSI (300 Bar)	p = 100 PSI (7 Bar)	p = 2000 PSI (140 Bar)	p = 4375 PSI (300 Bar)	4375 (300)	2800
	B02	0.35 (5.7)	2.75 (10.4)	2.32 (8.8)	1.80 (6.8)	0.74 (0.55)	4.01 (2.99)	8.58 (6.40)		
	B03	0.60 (9.8)	5.18 (17.6)	4.20 (15.9)	3.70 (14.0)	0.84 (0.63)	6.24 (4.65)	13.75 (10.25)		
	B04	0.78 (12.8)	6.08 (23.0)	5.65 (21.4)	5.12 (19.4)	0.94 (0.70)	7.90 (5.89)	17.61 (13.13)		
	B05	0.97 (15.9)	7.56 (28.6)	7.11 (26.9)	6.60 (25.0)	1.02 (0.76)	9.62 (7.17)	21.62 (16.12)		
	B06	1.21 (19.8)	9.40 (35.6)	8.96 (33.9)	8.45 (32.0)	1.13 (0.84)	11.79 (8.79)	26.66 (19.88)		
	B07	1.37 (22.5)	10.67 (40.4)	10.25 (38.8)	9.72 (36.8)	1.19 (0.89)	13.29 (9.91)	30.13 (22.47)		
	B08	1.52 (24.9)	11.81 (44.7)	11.39 (43.1)	10.86 (41.1)	1.26 (0.94)	14.62 (10.90)	33.23 (24.78)		
	B09	1.71 (28.0)	13.29 (50.3)	12.84 (48.6)	12.42 (47.0)	1.35 (1.01)	16.35 (12.19)	37.24 (27.77)		
	B10	1.94 (31.8)	15.11 (57.2)	14.66 (55.5)	14.13 (53.5)	1.49 (1.11)	18.44 (13.75)	42.13 (31.42)		
	B11	2.13 (34.9)	16.62 (62.9)	16.17 (61.2)	15.67 (59.3)	1.54 (1.15)	20.17 (15.04)	43.21 (32.22)		
	B12	2.50 (40.9)	19.47 (73.7)	19.05 (72.1)	18.52 (70.1)	1.72 (1.28)	23.55 (17.56)	50.57 (37.71)		
	B14	2.75 (45.1)	21.35 (80.8)	20.92 (79.2)	20.34 (77.0)	1.82 (1.36)	25.79 (19.23)	55.48 (41.37)		
	B15	3.05 (50.0)	23.72 (89.8)	23.33 (88.3)	22.85 (86.5 (3)	1.97 (1.47)	28.54 (21.28)	57.34 (42.76 (3)		

(1) 025 - 028 - 031 = 2500 RPM max.

(2) 028 - 031 = 3062 PSI max. int.

Min Speed : 600 RPM

(3) B15 = 4083 PSI max. int.

PT67DB - W - 038 - B08 - 1 R 00 - A 1 - M0 *

① ② P1 P2 ④ ⑤ ⑥ ⑦ ⑧ ⑨ ⑩

③

① **Series** PT67DB - SAE-C 2-Bolt Mount

② **Use for Severe duty shaft only**

③ **Cam Ring for "P1"**

Volumetric displacement in³/ rev (cm³/rev)

014 = 2.90 (47.6)	035 = 6.77 (111.0)
017 = 3.55 (58.2)	038 = 7.34 (120.3)
020 = 4.03 (66.0)	042 = 8.30 (136.0)
024 = 4.85 (79.5)	045 = 8.89 (145.7)
028 = 5.47 (89.7)	050 = 9.64 (158.0)
031 = 6.00 (98.3)	

Cam Ring for "P2"

B02 = 0.35 (5.7)	B09 = 1.71 (28.0)
B03 = 0.60 (9.8)	B10 = 1.94 (31.8)
B04 = 0.78 (12.8)	B11 = 2.13 (34.9)
B05 = 0.97 (15.9)	B12 = 2.50 (40.9)
B06 = 1.21 (19.8)	B14 = 2.75 (45.1)
B07 = 1.37 (22.5)	B15 = 3.05 (50.0)
B08 = 1.52 (24.9)	

④ **Type of Shaft**

- | | |
|---------------------|----------------------|
| 1 = Keyed (SAE C) | 2 = Keyed (No SAE) |
| 3 = Splined (SAE C) | 4 = Splined (No SAE) |
| 5 = Keyed (No SAE) | |
- (PT67DBW only)

⑤ **Rotation**
(viewed from shaft end)
R= clockwise
L= counter-clockwise

⑥ **Porting Combination**
00=Standard

⑦ **Design Letter**

⑧ **Seal Class**
1= S1 HNBR (for mineral oil)
4= S4 EPDM (for fire resistant fluids)
5= S5 Viton (for mineral oil and fire resistant fluids)

⑨ **Mounting W/connection variables**

P1 = 1 1/4" , P2 = 3/4" , S = 3"	
Unc	Metric
11	M1

⑩ **Modifications**

HYDROMECHANICAL POWER LOSS (TYPICAL)

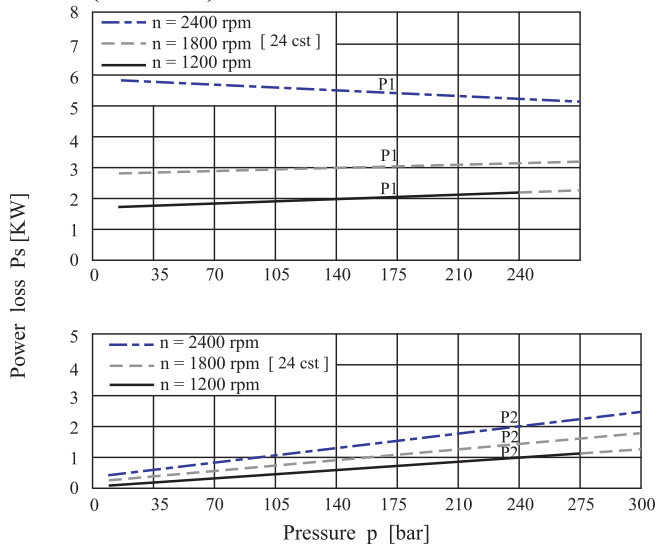

Do not operate pump more than 5 seconds at any speed or viscosity if internal leakage is more than 50% of theoretical flow.

Total leakage is the sum of each section loss at its operating conditions

INTERNAL LEAKAGE (TYPICAL)

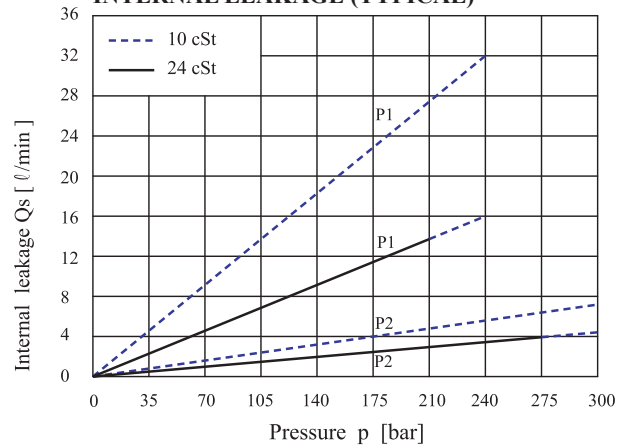

PERMISSIBLE RADIAL LOAD

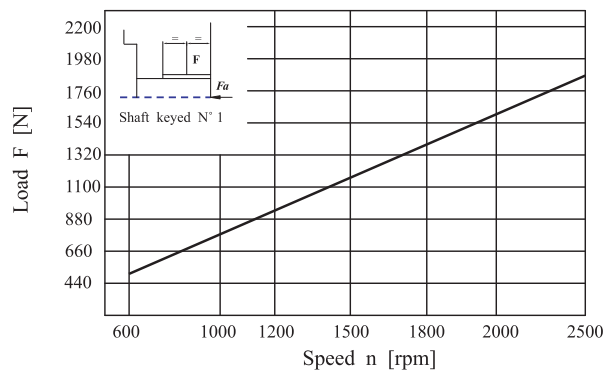



PT67DB Dimensional Drawing

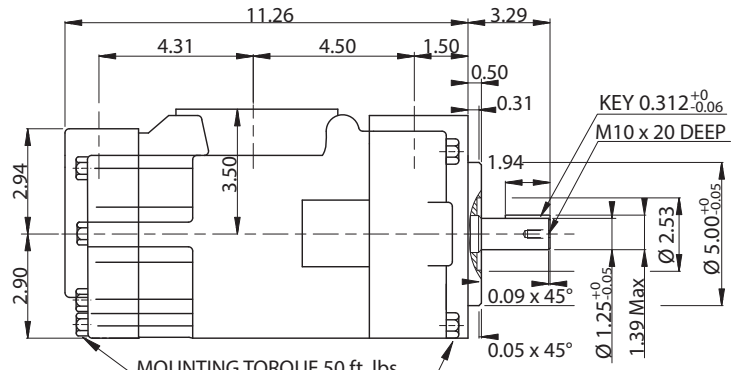
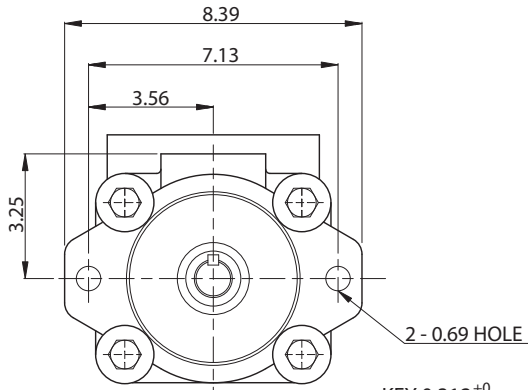

Shaft Code 3
SAE C Splined Shaft
12/24 dp. - 14 teeth
30° pressure angle
Flat root side fit.

Shaft Code 4
No SAE Splined Shaft
12/24 dp. - 14 teeth
30° pressure angle
Flat root side fit.

Shaft Code 5
(Keyed no SAE)

Shaft Code 1
(Keyed SAE C)

Shaft Code 3
SAE C Splined Shaft
12/24 dp. - 14 teeth
30° pressure angle
Flat root side fit.

Shaft Code 4
No SAE Splined Shaft
12/24 dp. - 14 teeth
30° pressure angle
Flat root side fit.

Shaft Code 5
(Keyed no SAE)

Shaft Code 1
(Keyed SAE C)

PT67DBW

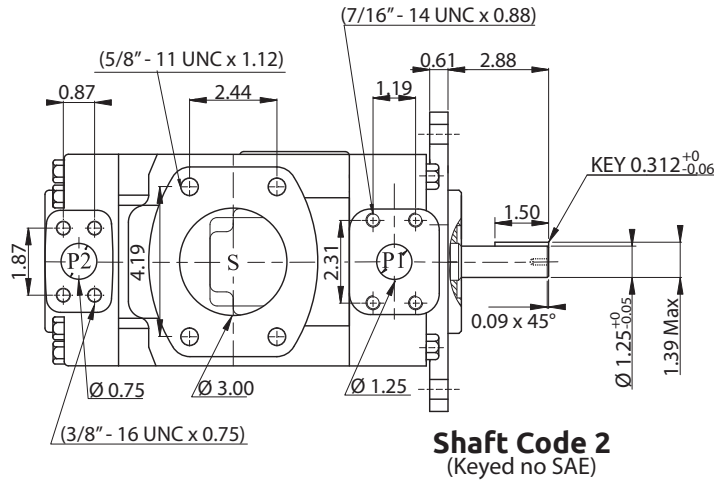

Shaft Code 2
(Keyed no SAE)

Shaft torque limits in ³ /rev x PSI (cm ³ /rev x Bar)		
Pump	Shaft	Vp x p max. P1 + P2
PT6DB	1	38299 (43240)
	2	30638 (34590)
	3	54207 (61200)
	4	54207 (61200)
	5	49247 (55600)

PT67DB OPERATING CHARACTERISTICS - TYPICAL 115 SUS (24 cst)

Pressure Port	Series	Volumetric Displacement in ³ /rev (cm ³ /rev)	Flow Q in GPM (l/min) @ 1800 RPM			Input Power HP (KW) @ 1800 RPM			P. Max PSI (Bar)	MAX RPM	
			p = 0 PSI (0 Bar)	p = 2000 PSI (140 Bar)	p = 3500 PSI (240 Bar)	p = 100 PSI (7 Bar)	p = 2000 PSI (140 Bar)	p = 3500 PSI (240 Bar)			
P1	014	2.90 (47.6)	22.45 (85.0)	20.45 (77.4)	18.78 (71.1)	4.01 (2.99)	28.94 (21.58)	9.72 (36.79)	3500 (240)	2500	
	017	3.55 (58.2)	23.06 (87.3)	20.61 (78.0)	18.97 (71.8)	3.35 (2.50)	29.77 (22.20)	49.62 (37.00)			
	020	4.03 (66.0)	31.33 (118.6)	26.79 (101.4)	27.53 (104.2)	4.53 (3.38)	39.52 (29.47)	13.24 (50.11)			
	024	4.85 (79.5)	37.72 (142.8)	35.56 (134.6)	33.95 (128.5)	4.91 (3.66)	47.02 (35.06)	80.31 (59.89)			
	028	5.47 (89.7)	42.61 (161.3)	40.42 (153.0)	38.78 (146.8)	5.19 (3.87)	52.68 (39.28)	90.22 (67.28)			
	031	6.00 (98.3)	46.68 (176.7)	44.51 (168.5)	42.88 (162.3)	5.48 (4.09)	57.45 (42.84)	98.58 (73.51)			
	035	6.77 (111.0)	52.73 (199.6)	50.54 (191.3)	48.63 (184.1)	5.78 (4.31)	64.49 (48.09)	110.90 (82.70)			
	038	7.34 (120.3)	57.14 (216.3)	54.97 (208.1)	53.31 (201.8)	6.03 (4.50)	69.65 (51.94)	111.94 (83.47)			
	042	8.30 (136.0)	64.59 (244.5)	62.42 (236.3)	60.79 (230.1)	6.48 (4.83)	78.37 (58.44)	135.19 (100.81)			
	045	8.89 (145.7)	69.19 (261.9)	67.02 (253.7)	65.38 (247.5)	6.73 (5.02)	83.75 (62.45)	144.60 (107.83)			
050	9.64 (158.0)	75.05 (284.1)	72.86 (275.8)	71.67 (271.3 (2)	7.07 (5.27)	90.57 (67.54)	134.53 (100.32 (2)	3062(210)	2200		
P2	Series	in ³ /rev (cm ³ /rev)	p = 0 PSI (0 Bar)	p = 2000 PSI (140 Bar)	p = 4375 PSI (300 Bar)	p = 100 PSI (7 Bar)	p = 2000 PSI (140 Bar)	p = 4375 PSI (300 Bar)	4375 (300)	2500	
	B02	0.35 (5.8)	2.75 (10.4)	2.32 (8.8)	1.80 (6.8)	0.74 (0.55)	4.01 (2.99)	8.58 (6.40)			
	B03	0.60 (9.8)	4.65 (17.6)	4.20 (15.9)	3.70 (14.0)	0.84 (0.63)	6.24 (4.65)	13.75 (10.25)			
	B04	0.78 (12.8)	6.08 (23.0)	5.65 (21.4)	5.12 (19.4)	0.94 (0.70)	7.90 (5.89)	17.61 (13.13)			
	B05	0.97 (15.9)	7.56 (28.6)	7.11 (26.9)	6.60 (25.0)	1.02 (0.76)	9.62 (7.17)	21.62 (16.12)			
	B06	1.21 (19.8)	9.40 (35.6)	8.96 (33.9)	8.45 (32.0)	1.13 (0.84)	11.79 (8.79)	26.66 (19.88)			
	B07	1.37 (22.5)	10.67 (40.4)	10.25 (38.8)	9.72 (36.8)	1.19 (0.89)	13.29 (9.91)	30.13 (22.47)			
	B08	1.52 (24.9)	11.81 (44.7)	11.39 (43.1)	10.86 (41.1)	1.26 (0.94)	14.62 (10.90)	33.23 (24.78)			
	B09	1.71 (28.0)	13.29 (50.3)	12.84 (48.6)	12.42 (47.0)	1.35 (1.01)	16.35 (12.19)	37.24 (27.77)			
	B10	1.94 (31.8)	15.11 (57.2)	14.66 (55.5)	14.13 (53.5)	1.49 (1.11)	18.44 (13.75)	42.13 (31.42)			
	B11	2.13 (34.9)	16.62 (62.9)	16.17 (61.2)	15.67 (59.3)	1.54 (1.15)	20.17 (15.04)	43.21 (32.22)			
	B12	2.50 (40.9)	19.47 (73.7)	19.05 (72.1)	18.52 (70.1)	1.72 (1.28)	23.55 (17.56)	50.57 (37.71)			
	B14	2.75 (45.1)	21.35 (80.8)	20.92 (79.2)	20.34 (77.0)	1.82 (1.36)	25.79 (19.23)	55.48 (41.37)			
	B15	3.05 (50.0)	23.72 (89.8)	23.33 (88.3)	22.85 (86.5 (3)	1.97 (1.47)	28.54 (21.28)	57.34 (42.76 (3)			4083 (280)

(1) 042 - 045 - 050 = 2200 RPM max.

(2) 050 = 3000 PSI max. int.

(3) B15 = 4083 PSI max. int.

Min Speed : 600 RPM

PT67QDC*P2Z - 038 - 022 - 1 R 00 - A 1 - 00 *

1
P1
P2
3
4
5
6
7
8
9

②

① **Series** PT67QDCP2Z/ PT67QDCMP2Z
SAE-C 2 & 4 Bolt Mount

② **Cam Ring for "P1"**

Volumetric displacement in³/ rev (cm³/rev)

014 = 2.90 (47.6)	035 = 6.77 (111.0)
017 = 3.55 (58.2)	038 = 7.34 (120.3)
020 = 4.03 (66.0)	042 = 8.30 (136.0)
024 = 4.85 (79.5)	045 = 8.89 (145.7)
028 = 5.47 (89.7)	050 = 9.64 (158.0)
031 = 6.00 (98.3)	

Cam Ring for "P2"

003 = 0.66 (10.8)	017 = 3.56 (58.3)
005 = 1.05 (17.2)	020 = 3.89 (63.8)
006 = 1.30 (21.3)	022 = 4.29 (70.3)
008 = 1.61 (26.4)	025 = 4.84 (79.3)
010 = 2.08 (34.1)	028 = 5.42 (88.8)
012 = 2.26 (37.1)	031 = 6.10 (100.0)
014 = 2.81 (46.0)	

③ **Type of Shaft**

- 1 = Keyed (SAE C)
- 2 = Keyed (SAE CC)
- 3 = Splined (SAE C)

HYDROMECHANICAL POWER LOSS (TYPICAL)

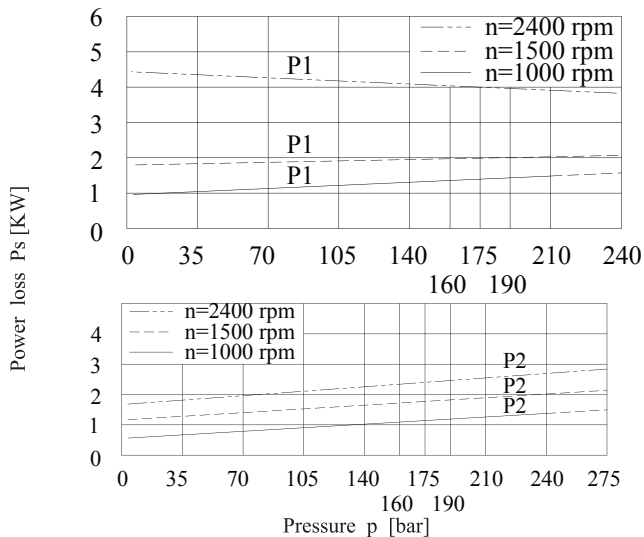

Do not operate pump more than 5 seconds at any speed or viscosity if internal leakage is more than 50% of theoretical flow.

Total leakage is the sum of each section loss at its operating conditions

⑤ **Rotation**
(viewed from shaft end)
R= clockwise
L= counter-clockwise

④

⑥ **Porting Combination**
00=Standard

⑦ **Design Letter**

⑧ **Seal Class**

- 1= S1 HNBR (for mineral oil)
- 4= S4 EPDM (for fire resistant fluids)
- 5= S5 Viton (for mineral oil and fire resistant fluids)

⑨ **Mounting W/connection variables**

P1 = 1 1/4" , P2 = 3/4" , S = 3"	
Unc	Metric
11	M1

⑩ **Modifications**

INTERNAL LEAKAGE (TYPICAL)

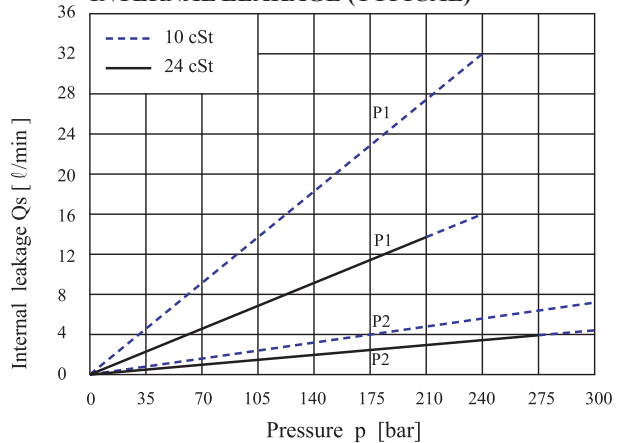

PERMISSIBLE RADIAL LOAD

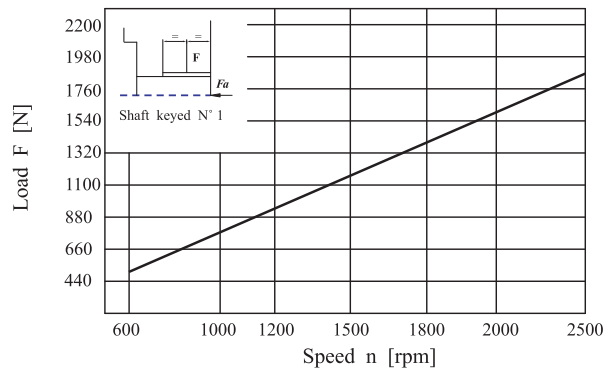

Maximum permissible axial load Fa = 1200 N



PT67QDCP2Z Dimensional Drawing

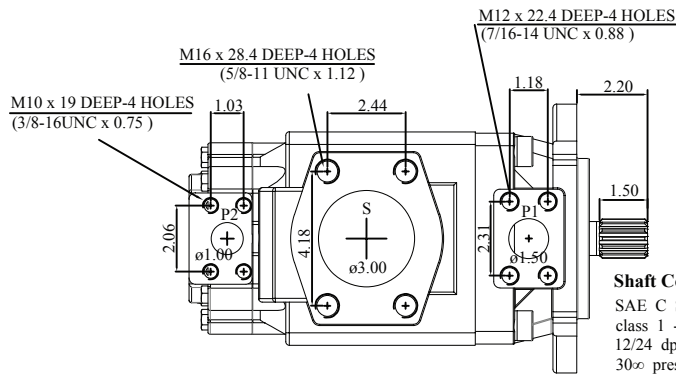
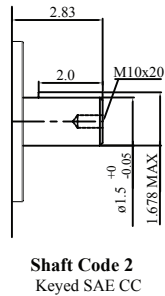
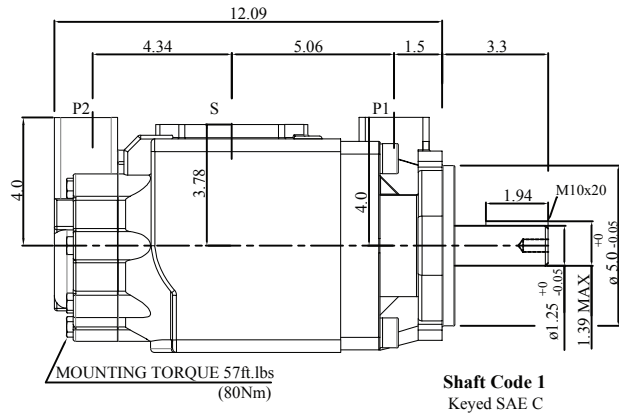
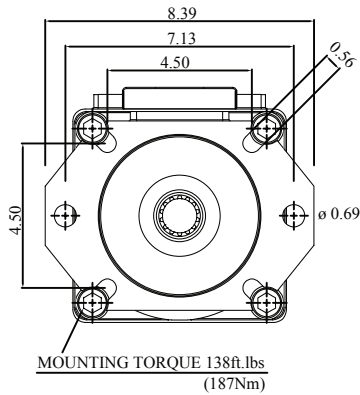

Shaft torque limits (ml/rev x bar)		
Pump	Shaft	Vp x p max.P1+P2
PT67QDCP2Z	1	43240
	2	61200
	3	35880

PT67QDCP2Z OPERATING CHARACTERISTICS - TYPICAL 115 SUS (24 cSt)

Pressure Port	Series	Volumetric Displacement in ³ /rev (cm ³ /rev)	Flow Q in GPM (l/min) @ 1800 RPM			Input Power HP (KW) @ 1800 RPM			P. Max PSI (Bar)	MAX RPM
			p = 0 PSI (0 Bar)	p = 2000 PSI (140 Bar)	p = 3500 PSI (240 Bar)	p = 100 PSI (7 Bar)	p = 2000 PSI (140 Bar)	p = 3500 PSI (240 Bar)		
P1	B14	2.68 (43.9)	22.45 (79.1)	19.15 (72.5)	17.78 (67.3)	3.49 (2.60)	27.76 (20.7)	46.94 (35.0)	3500 (250)	2500
	B17	3.36 (55.0)	23.06 (98.8)	24.38 (92.3)	22.98 (87.0)	3.75 (2.80)	33.93 (25.3)	57.66 (43.0)		
	B20	4.03 (66.0)	31.33 (118.6)	29.59 (112.0)	28.21 (106.8)	4.02 (3.00)	39.96 (29.8)	68.26 (50.9)		
	B24	4.95 (81.1)	37.72 (145.8)	36.77 (139.2)	35.40 (134.0)	4.56 (3.40)	48.41 (36.1)	83.00 (61.9)		
	B28	5.49 (89.9)	42.61 (161.3)	41.00 (155.2)	39.63 (150.0)	4.69 (3.50)	53.24 (39.7)	91.59 (68.3)		
	B31	6.05 (99.1)	46.68 (176.7)	45.36 (171.7)	43.98 (166.5)	4.96 (3.70)	58.47 (43.6)	100.58 (75.0)		
	B35	6.92 (113.4)	52.73 (199.6)	52.09 (197.2)	50.72 (192.0)	5.36 (4.00)	66.25 (49.4)	114.39 (85.3)		
	B38	7.36 (120.6)	57.14 (216.3)	55.53 (210.2)	54.13 (204.9)	5.63 (4.20)	70.27 (52.4)	121.36 (90.5)		
	B42	8.39 (137.5)	64.59 (244.5)	63.56 (240.6)	62.19 (235.4)	6.03 (4.50)	79.66 (59.4)	137.72 (102.7)		
	B45	8.89 (145.7)	69.19 (261.9)	66.99 (253.6)	65.20 (246.8)	6.71 (5.00)	83.68 (62.4)	145.77 (108.7)		
	B50	9.64 (157.9)	75.05 (284.1)	72.86 (275.8)	71.67 (271.3 (1)	7.11 (5.30)	90.52 (67.5)	134.53 (100.3 (1)	3062(210)	2200
P2	Series	in ³ /rev (cm ³ /rev)	p = 0 PSI (0 Bar)	p = 2000 PSI (140 Bar)	p = 4375 PSI (300 Bar)	p = 100 PSI (7 Bar)	p = 2000 PSI (140 Bar)	p = 4375 PSI (300 Bar)	4375 (300)	2500
	003	0.66 (10.8)	5.18 (19.6)	3.86 (14.6)		2.11 (1.57)	8.45 (6.30)			
	005	1.05 (17.2)	8.16 (30.9)	6.87 (26.0)	4.34 (16.44)	2.28 (1.70)	11.99 (8.94)	23.98 (17.88)		
	006	1.30 (21.3)	10.12 (38.3)	8.82 (33.4)	5.71 (21.60)	2.39 (1.78)	14.27 (10.64)	28.97 (21.60)		
	008	1.61 (26.4)	12.52 (47.4)	11.25 (42.6)	8.12 (30.72)	2.53 (1.89)	17.10 (12.75)	35.08 (26.16)		
	010	2.08 (34.1)	16.19 (61.3)	14.90 (56.4)	11.79 (44.64)	2.76 (2.06)	21.38 (15.94)	44.25 (33.00)		
	012	2.26 (37.1)	17.62 (66.7)	16.33 (61.8)	13.22 (50.04)	2.83 (2.11)	23.04 (17.18)	47.47 (35.40)		
	014	2.81 (46.0)	21.85 (82.7)	20.55 (77.8)	17.44 (66.00)	3.08 (2.30)	27.97 (20.87)	58.74 (43.80)		
	017	3.56 (58.3)	27.69 (104.8)	26.39 (99.9)	23.30 (88.20)	3.42 (2.55)	34.80 (25.95)	73.54 (54.84)		
	020	3.89 (63.8)	30.30 (114.7)	29.01 (109.8)	25.90 (98.04)	3.57 (2.66)	37.86 (28.23)	80.14 (59.76)		
	022	4.29 (70.3)	33.39 (126.4)	32.10 (121.5)	29.01 (109.8)	3.75 (2.80)	41.46 (30.92)	80.94 (60.36 (2)		
	025 (3)	4.84 (79.3)	37.64 (142.5)	36.35 (137.6)		4.01 (2.99)	46.45 (34.64)			
	028 (4)	5.42 (88.8)	42.16 (159.6)	40.87 (154.7)		4.26 (3.18)	51.74 (38.58)			
	031 (4)	6.10 (100.00)	47.47 (179.7)	46.20 (174.9)		4.57 (3.41)	57.95 (43.21)			

(1) B50 = 3062 PSI max. int.

(2) 022 = 4000 PSI max. int.

(3) 025 = 3500 PSI max. int.

(4) 028 - 031 = 3062 PSI max. int.

Min Speed : 600 RPM



PT67EB Ordering Code

PT67EB - 038 - B08 - 1 R 00 - A 1 - M1 *
 (1) [P1] [P2] (3) (4) (5) (6) (7) (8) (9)

① **Series** PT67EB - SAE-C 2-Bolt Mount

② **Cam Ring for "P1"**

Volumetric displacement in³/ rev (cm³/rev)

042 = 8.07 (132.3) 062 = 12.00 (196.7)
 045 = 8.69 (142.4) 066 = 13.02 (213.3)
 050 = 9.67 (158.5) 072 = 13.86 (227.1)
 052 = 10.06 (164.8) 085 = 16.46 (269.8)

Cam Ring for "P2"

B02 = 0.35 (5.7) B09 = 1.71 (28.0)
 B03 = 0.60 (9.8) B10 = 1.94 (31.8)
 B04 = 0.78 (12.8) B11 = 2.13 (34.9)
 B05 = 0.97 (15.9) B12 = 2.50 (40.9)
 B06 = 1.21 (19.8) B14 = 2.75 (45.1)
 B07 = 1.37 (22.5) B15 = 3.05 (50.0)
 B08 = 1.52 (24.9)

③ **Type of Shaft**

- 1 = Keyed (SAE CC)
- 2 = Keyed (No SAE)
- 3 = Splined (SAE C)
- 4 = Splined (SAE CC)

④ **Rotation**
(viewed from shaft end)

- R= clockwise
- L= counter-clockwise

⑤ **Porting Combination**
00=Standard

⑥ **Design Letter**

⑦ **Seal Class**

- 1= S1 HNBR (for mineral oil)
- 4= S4 EPDM (for fire resistant fluids)
- 5= S5 Viton (for mineral oil and fire resistant fluids)

⑧ **Mounting W/connection variables**

P1 = 1-1/2", P2 = 3/4", S = 3-1/2"	
Unc	Metric
01	M1

⑨ **Modifications**

HYDROMECHANICAL POWER LOSS (TYPICAL)

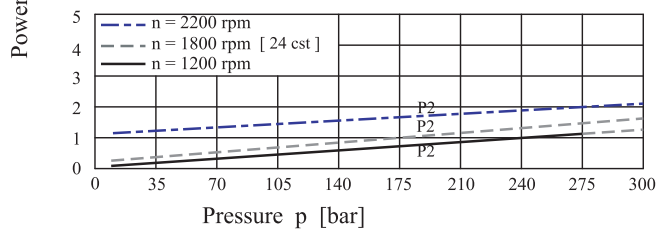
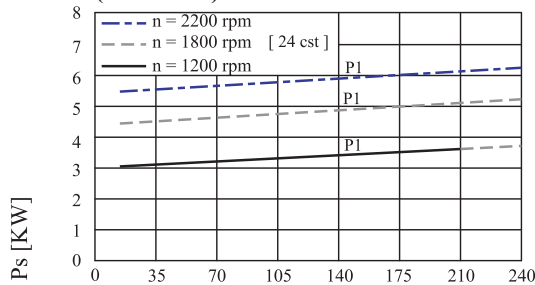

Do not operate pump more than 5 seconds at any speed or viscosity if internal leakage is more than 50% of theoretical flow.

Total leakage is the sum of each section loss at its operating conditions

INTERNAL LEAKAGE (TYPICAL)

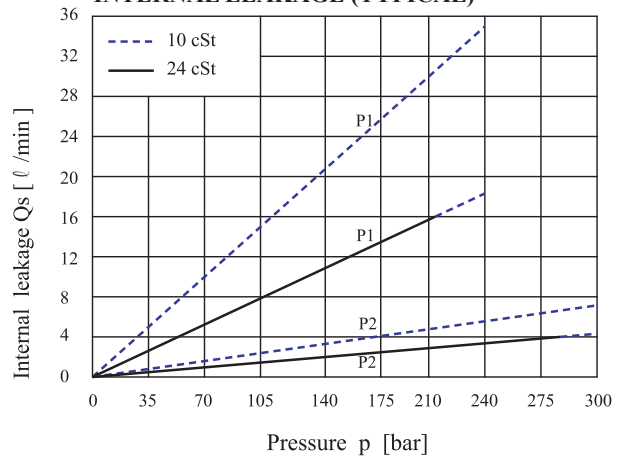

PERMISSIBLE RADIAL LOAD

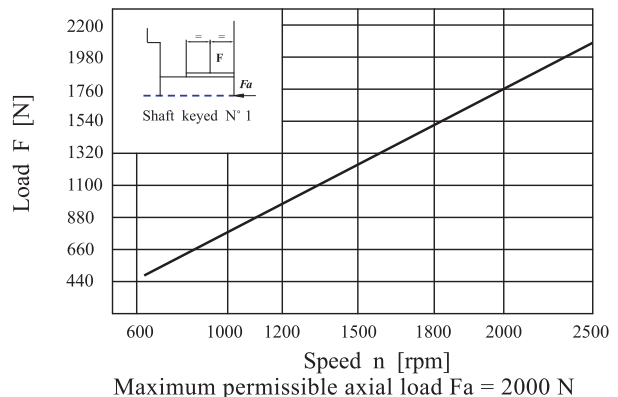



PT67EB Dimensional Drawing

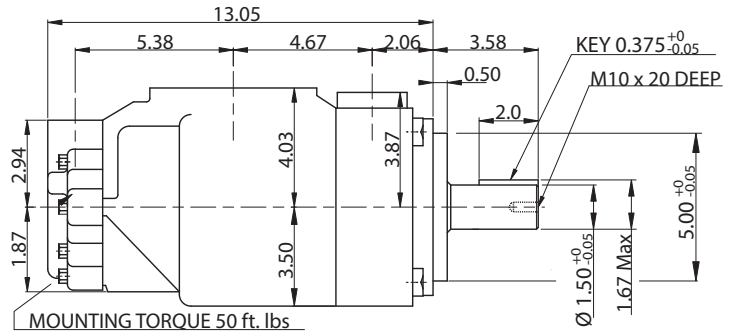
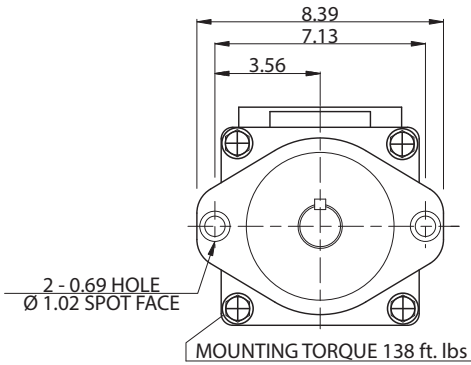

Shaft Code 1
(Keyed SAE CC)

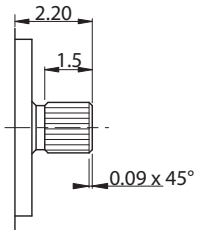

Shaft Code 3
SAE C Splined Shaft
12/24 dp. - 14 teeth
30° pressure angle
Flat root side fit.

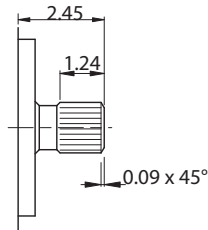

Shaft Code 4
SAE CC Splined Shaft
12/24 dp. - 17 teeth
30° pressure angle
Flat root side fit.

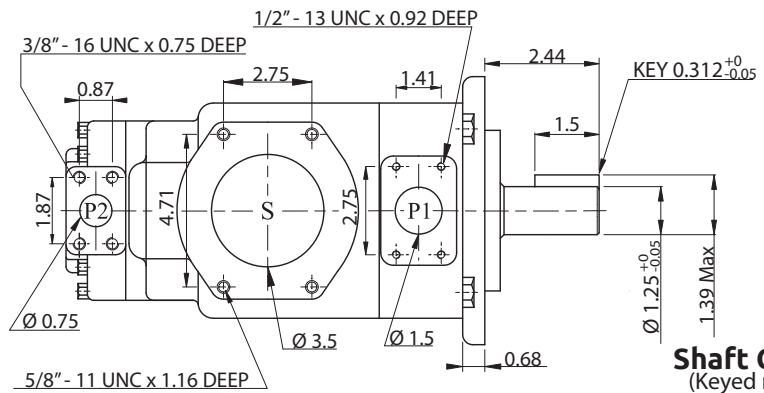

Shaft Code 2
(Keyed no SAE)

Shaft torque limits in ³ /rev x PSI (cm ³ /rev x Bar)		
Pump	Shaft	Vp x p max. P1 + P2
PT67EB	1	64044 (72306)
	2	30638 (34590)
	3	54207 (61200)
	4	67582 (76376)

PT67EB OPERATING CHARACTERISTICS - TYPICAL 115 SUS (24 cSt)

Pressure Port	Series	Volumetric Displacement in ³ /rev (cm ³ /rev)	Flow Q in GPM (l/min) @ 1800 RPM			Input Power HP (KW) @ 1800 RPM			P. Max PSI (Bar)	MAX RPM
			p = 0 PSI (0 Bar)	p = 2000 PSI (140 Bar)	p = 3500 PSI (240 Bar)	p = 100 PSI (7 Bar)	p = 2000 PSI (140 Bar)	p = 3500 PSI (240 Bar)		
P1	042	8.07 (132.3)	62.82 (237.8)	60.28 (228.2)	58.43 (221.2)	8.09 (6.03)	78.44 (58.49)	26.36 (99.78)	3500 (240)	2200
	045	8.69 (142.4)	67.63 (256.0)	65.07 (246.3)	63.24 (239.4)	8.37 (6.24)	84.04 (62.67)	143.60 (107.08)		
	050	9.67 (158.5)	75.29 (285.0)	72.73 (275.3)	70.88 (268.3)	8.82 (6.58)	92.93 (69.30)	31.36 (118.70)		
	052	10.06 (164.8)	78.25 (296.2)	75.63 (286.3)	73.86 (279.6)	8.98 (6.70)	96.47 (71.94)	162.68 (121.31)		
	062	12.00 (196.7)	93.41 (353.6)	90.88 (344.0)	89.03 (337.0)	9.87 (7.36)	112.65 (84.00)	196.34 (146.41)		
	066	13.02 (213.3)	101.28 (383.4)	98.75 (373.8)	96.90 (366.8)	10.34 (7.71)	123.39 (92.01)	212.46 (158.43)		
	072	13.86 (227.1)	107.84 (408.2)	105.67 (400.0)	103.45 (391.6)	10.73 (8.00)	131.04 (97.72)	225.85 (168.42)		
085 (1)	16.40 (268.7)	127.60 (483.0)	125.93 (476.7 (2)	()	11.67 (8.70)	87.57 (65.30 (2)	()	1450(100)	2000	
P2	Series	in ³ /rev (cm ³ /rev)	p = 0 PSI (0 Bar)	p = 2000 PSI (140 Bar)	p = 4375 PSI (300 Bar)	p = 100 PSI (7 Bar)	p = 2000 PSI (140 Bar)	p = 4375 PSI (300 Bar)	4375 (300)	2200
	B02	0.35 (5.7)	2.75 (10.4)	2.32 (8.8)	1.80 (6.8)	0.74 (0.55)	4.01 (2.99)	8.58 (6.40)		
	B03	0.60 (9.8)	4.65 (17.6)	4.20 (15.9)	3.70 (14.0)	0.84 (0.63)	6.24 (4.65)	13.75 (10.25)		
	B04	0.78 (12.8)	6.08 (23.0)	5.65 (21.4)	5.12 (19.4)	0.94 (0.70)	7.90 (5.89)	17.61 (13.13)		
	B05	0.97 (15.9)	7.56 (28.6)	7.11 (26.9)	6.60 (25.0)	1.02 (0.76)	9.62 (7.17)	21.62 (16.12)		
	B06	1.21 (19.8)	9.40 (35.6)	8.96 (33.9)	8.45 (32.0)	1.13 (0.84)	11.79 (8.79)	26.66 (19.88)		
	B07	1.37 (22.5)	10.67 (40.4)	10.25 (38.8)	9.72 (36.8)	1.19 (0.89)	13.29 (9.91)	30.13 (22.47)		
	B08	1.52 (24.9)	11.81 (44.7)	11.39 (43.1)	10.86 (41.1)	1.26 (0.94)	14.62 (10.90)	33.23 (24.78)		
	B09	1.71 (28.0)	13.29 (50.3)	12.84 (48.6)	12.42 (47.0)	1.35 (1.01)	16.35 (12.19)	37.24 (27.77)		
	B10	1.94 (31.8)	15.11 (57.2)	14.66 (55.5)	14.13 (53.5)	1.49 (1.11)	18.44 (13.75)	42.13 (31.42)		
	B11	2.13 (34.9)	16.62 (62.9)	16.17 (61.2)	15.67 (59.3)	1.54 (1.15)	20.17 (15.04)	43.21 (32.22)		
	B12	2.50 (40.9)	19.47 (73.7)	19.05 (72.1)	18.52 (70.1)	1.72 (1.28)	23.55 (17.56)	50.57 (37.71)		
	B14	2.75 (45.1)	21.35 (80.8)	20.92 (79.2)	20.34 (77.0)	1.82 (1.36)	25.79 (19.23)	55.48 (41.37)		
B15	3.05 (50.0)	23.72 (89.8)	23.33 (88.3)	22.85 (86.5 (3)	1.97 (1.47)	28.54 (21.28)	57.34 (42.76 (3)	4083 (280)		

(1) 085 = 2200 RPM max.

(2) 085 = 1087 PSI max. int.
085 = 1305 PSI max. int.

(3) B15 = 4083 PSI max. int.

Min Speed : 600 RPM



PT6DCC Ordering Code

PT6DCC/PT6DCCM - 038 -022 -008 -1 R 00 - A 1 - 00 *

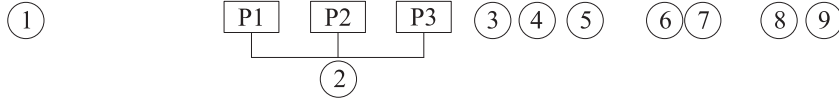

① **Series** PT6DCC/PT6DCCM - SAE-C 2-Bolt Mount

② **Cam Ring for "P1"**
Volumetric displacement in³/ rev (cm³/rev)

014/B14 = 2.90 (47.6)	035/B35 = 6.77 (111.0)
017/B17 = 3.55 (58.2)	038/B38 = 7.34 (120.3)
020/B20 = 4.03 (66.0)	042/B42 = 8.30 (136.0)
024/B24 = 4.85 (79.5)	045/B45 = 8.89 (145.7)
028/B28 = 5.47 (89.7)	050/B50 = 9.64 (158.0)
031/B31 = 6.00 (98.3)	

Cam Ring for "P2" & "P3"

003/B03 = 0.66 (10.8)	017/B17 = 3.56 (58.3)
005/B05 = 1.05 (17.2)	020/B20 = 3.89 (63.8)
006/B06 = 1.30 (21.3)	022/B22 = 4.29 (70.3)
008/B08 = 1.61 (26.4)	025/B25 = 4.84 (79.3)
010/B10 = 2.08 (34.1)	028/B28 = 5.42 (88.8)
012/B12 = 2.26 (37.1)	031/B31 = 6.10 (100.0)
014/B14 = 2.81 (46.0)	

③ **Type of Shaft**

- 1 = Keyed (No SAE)
- 2 = Keyed (SAE CC)
- 3 = Splined (SAE C)
- 4 = Splined (SAE CC)

④ **Rotation**
(viewed from shaft end)

- R= clockwise
- L= counter-clockwise

⑤ **Porting Combination**
00=Standard

⑥ **Design Letter**

- A = Industrial
- B = Mobile

⑦ **Seal Class**

- 1= S1 HNBR (for mineral oil)
- 4= S4 EPDM (for fire resistant fluids)
- 5= S5 Viton (for mineral oil and fire resistant fluids)

⑧ **Mounting W/connection variables**

	Unc		Metric	
	00	01	M0	M1
P3	1"	3/4"	1"	3/4"

⑨ **Modifications**

HYDROMECHANICAL POWER LOSS (TYPICAL)

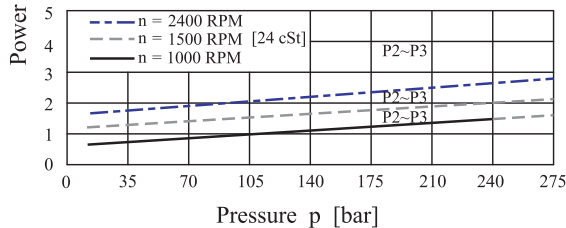
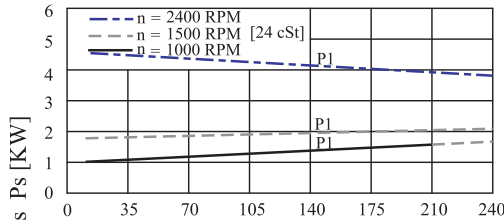

Do not operate pump more than 5 seconds at any speed or viscosity if internal leakage is more than 50% of theoretical flow.

Total leakage is the sum of each section loss at its operating conditions

INTERNAL LEAKAGE (TYPICAL)

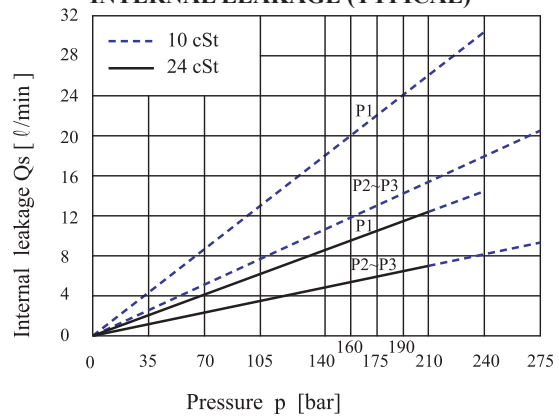

PERMISSIBLE RADIAL LOAD

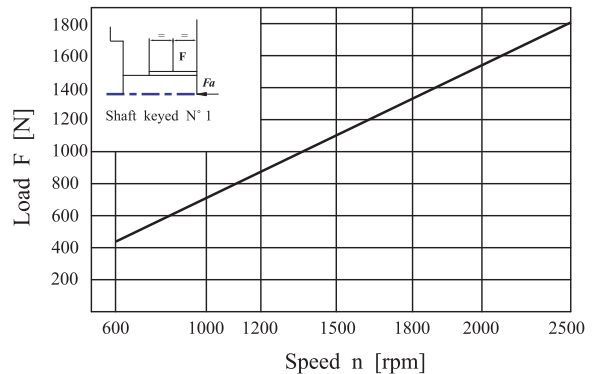

Maximum permissible axial load Fa = 1200 N



PT6DCC Dimensional Drawing

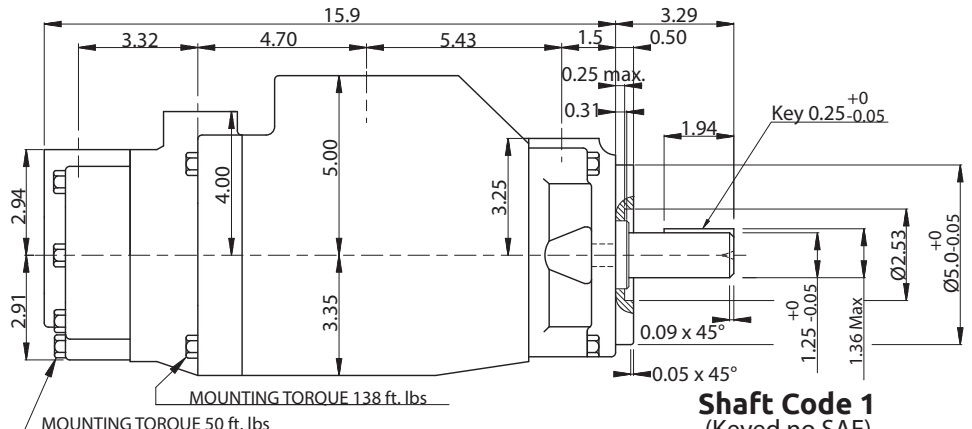
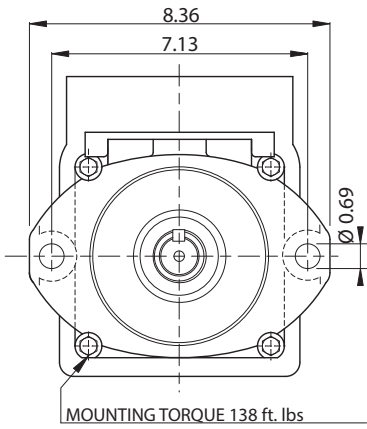

Shaft Code 1
(Keyed no SAE)

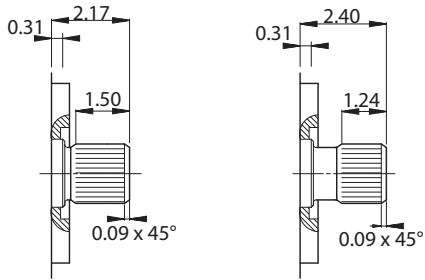

Shaft Code 3
SAE C Splined Shaft
12/24 dp. 14 teeth
30° pressure angle
Flat root side fit

Shaft Code 4
SAE CC Splined Shaft
12/24 dp. 17 teeth
30° pressure angle
Flat root side fit

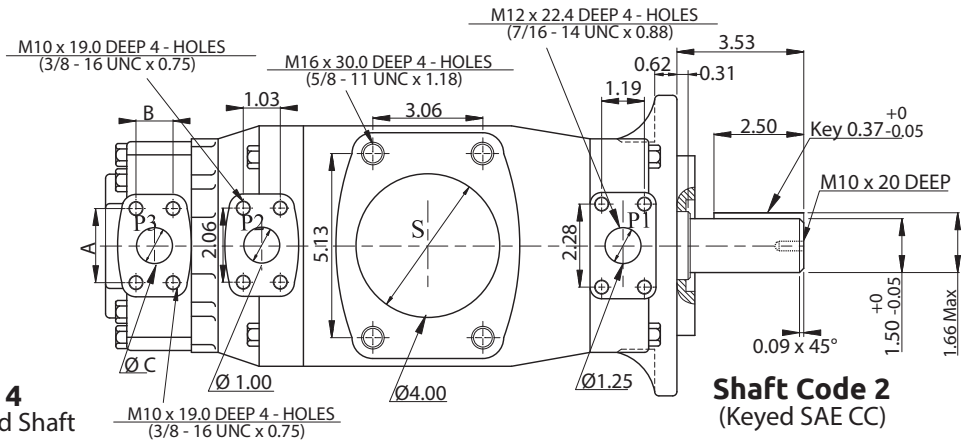

Shaft Code 2
(Keyed SAE CC)

Shaft torque limits in ³ /rev x PSI (cm ³ /rev x Bar)	
Shaft	Vp x p max. (P1 + P2 + P3)
1	38299 (43240)
2	58901 (66500)
3	54027 (61200)
5	58901 (66500)

PORT	CODE	A	B	C
P3	00 & M0	2.06	1.03	1.00
	01 & M1	1.874	0.874	0.75

PT6DCC/PT6DCCM OPERATING CHARACTERISTICS - TYPICAL 115 SUS (24 cSt)

Pressure Port	Series	Volumetric Displacement in ³ /rev (cm ³ /rev)	Flow Q in GPM (l/min) @ 1500 RPM			Input Power HP (KW) @ 1500 RPM			P. Max PSI (Bar)	MAX RPM
			p = 0 PSI (0 Bar)	p = 2000 PSI (140 Bar)	p = 3500 PSI (240 Bar)	p = 100 PSI (7 Bar)	p = 2000 PSI (140 Bar)	p = 3500 PSI (240 Bar)		
P1	B/014	2.90 (47.6)	18.86 (71.4)	16.41 (62.1)	14.77 (55.9)	3.08 (2.3)	24.81 (18.5)	41.04 (30.6)	3500 (240)	2500
	B/017	3.55 (58.2)	23.06 (87.3)	20.61 (78.0)	18.97 (71.8)	3.35 (2.5)	29.77 (22.2)	49.62 (37.0)		
	B/020	4.03 (66.0)	26.15 (99.0)	23.70 (89.7)	22.06 (83.5)	3.75 (2.8)	33.39 (24.9)	55.92 (41.7)		
	B/024	4.85 (79.5)	31.52 (119.3)	29.06 (110.0)	27.42 (103.8)	4.02 (3.0)	39.69 (29.6)	66.78 (49.8)		
	B/028	5.47 (89.7)	35.53 (134.5)	33.07 (125.2)	31.44 (119.0)	4.29 (3.2)	44.52 (33.2)	74.96 (55.9)		
	B/031	6.00 (98.3)	38.97 (147.5)	36.48 (138.1)	34.84 (131.9)	4.43 (3.3)	48.54 (36.2)	81.80 (61.0)		
	B/035	6.77 (111.0)	43.98 (166.5)	41.53 (157.2)	39.89 (151.0)	4.69 (3.5)	54.58 (40.7)	92.13 (68.7)		
	B/038	7.34 (120.3)	47.66 (180.4)	45.20 (171.1)	43.56 (164.9)	4.96 (3.7)	58.87 (43.9)	99.64 (74.3)		
	B/042 (1)	8.30 (136.0)	53.89 (204.0)	51.43 (194.7)	49.80 (188.5)	5.36 (4.0)	66.25 (49.4)	112.24 (83.7)		
	B/045 (1)	8.89 (145.7)	57.72 (218.5)	55.26 (209.2)	53.63 (203.0)	5.50 (4.1)	70.81 (52.8)	120.02 (89.5)		
B/050 (1)	9.64 (158.0)	62.61 (237.0)	60.15 (227.7)	59.17 (224.0 (2)	5.90 (4.4)	76.44 (57.0)	113.99 (85.0 (2)	3062 (210)	2200	
P2&P3	B/003	0.66 (10.8)	4.28 (16.2)	2.96 (11.2)	2.03 (7.7)	1.74 (1.3)	7.11 (5.3)	11.26 (8.4)	4010 (275)	2500
	B/005	1.05 (17.2)	6.82 (25.8)	5.49 (20.8)	4.57 (17.3)	1.88 (1.4)	10.06 (7.5)	16.36 (12.2)		
	B/006	1.30 (21.3)	8.43 (31.9)	7.11 (26.9)	6.18 (23.4)	2.01 (1.5)	11.94 (8.9)	19.71 (14.7)		
	B/008	1.61 (26.4)	10.46 (39.6)	9.14 (34.6)	8.22 (31.1)	2.15 (1.6)	14.35 (10.7)	23.74 (17.7)		
	B/010	2.08 (34.1)	13.50 (51.1)	12.18 (46.1)	11.25 (42.6)	2.28 (1.7)	17.97 (13.4)	29.90 (22.3)		
	B/012	2.26 (37.1)	14.69 (55.6)	13.37 (50.6)	12.44 (47.1)	2.28 (1.7)	19.31 (14.4)	32.32 (24.1)		
	B/014	2.81 (46.0)	18.23 (69.0)	16.91 (64.0)	15.98 (60.5)	2.55 (1.9)	23.60 (17.6)	39.56 (29.5)		
	B/017	3.56 (58.3)	23.09 (87.4)	21.77 (82.4)	20.84 (78.9)	2.82 (2.1)	29.37 (21.9)	49.48 (36.9)		
	B/020	3.89 (63.8)	25.28 (95.7)	23.96 (90.7)	23.04 (87.2)	2.95 (2.2)	31.92 (23.8)	53.91 (40.2)		
	B/022	4.29 (70.3)	27.84 (105.4)	26.52 (100.4)	25.60 (96.9)	3.08 (2.3)	35.00 (26.1)	59.14 (44.1)		
	B/025	4.84 (79.3)	31.41 (118.9)	30.09 (113.9)	29.16 (110.4)	3.35 (2.5)	39.16 (29.2)	66.38 (49.5)		
	B/028	5.42 (88.8)	35.19 (133.2)	33.87 (128.2)	33.23 (125.8 (3)	3.75 (2.8)	43.85 (32.7)	65.04 (48.5 (3)		
B/031	6.10 (100.0)	39.63 (150.0)	38.30 (145.0)	37.67 (142.6 (3)	3.75 (2.8)	48.95 (36.5)	72.95 (54.4 (3)			

(1) 042 - 045 - 050 = 2200 RPM max.

(2) 050 = 3000 PSI max. int.

(3) B15 = 4083 PSI max. int.

Min Speed : 600 RPM



PT6DDCS Ordering Code

PT6DDCS/PT6DDCSM - 038 - 022 - 008 - 1 R 00 - A 1 - 00 *

1
P1
P2
P3
3
4
5
6
7
8
9

②

① **Series** PT6DDCS/PT6DDCSM - SAE-C 2 & 4 Bolt Mount

② **Cam Ring for "P1" & "P2"**
 Volumetric displacement in³/rev (cm³/rev)

014/B14 = 2.90 (47.6)	035/B35 = 6.77 (111.0)
017/B17 = 3.55 (58.2)	038/B38 = 7.34 (120.3)
020/B20 = 4.03 (66.0)	042/B42 = 8.30 (136.0)
024/B24 = 4.85 (79.5)	045/B45 = 8.89 (145.7)
028/B28 = 5.47 (89.7)	050/B50 = 9.64 (158.0)
031/B31 = 6.00 (98.3)	

Cam Ring for "P3"

003/B03 = 0.66 (10.8)	017/B17 = 3.56 (58.3)
005/B05 = 1.05 (17.2)	020/B20 = 3.89 (63.8)
006/B06 = 1.30 (21.3)	022/B22 = 4.29 (70.3)
008/B08 = 1.61 (26.4)	025/B25 = 4.84 (79.3)
010/B10 = 2.08 (34.1)	028/B28 = 5.42 (88.8)
012/B12 = 2.26 (37.1)	031/B31 = 6.10 (100.0)
014/B14 = 2.81 (46.0)	

③ **Type of Shaft**

- 1 = Keyed (SAE C)
- 2 = Keyed (SAE CC)
- 3 = Splined (SAE C)
- 4 = Splined (SAE CC)
- 5 = Keyed (No SAE)

④ **Rotation**
 (viewed from shaft end)
 R = clockwise
 L = counter-clockwise

⑤ **Porting Combination**
 00 = Standard

⑥ **Design Letter**

⑦ **Seal Class**

- 1 = S1 HNBR (for mineral oil)
- 4 = S4 EPDM (for fire resistant fluids)
- 5 = S5 Viton (for mineral oil and fire resistant fluids)

⑧ **Port Connection Variables**
 SAE 4 bolt flange (J518c)

P1 & P2 = 1-1/4" S = 4"				
	Unc		Metric	
CODE	00	01	M0	M1
P3	1"	3/4"	1"	3/4"

⑨ **Modifications**

HYDROMECHANICAL POWER LOSS (TYPICAL)

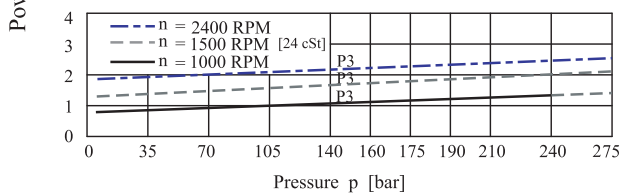
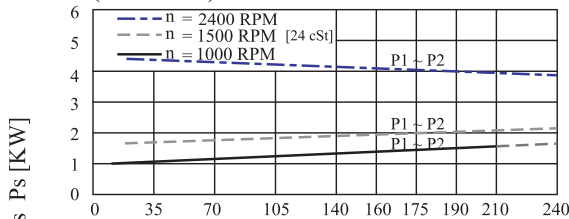

Do not operate pump more than 5 seconds at any speed or viscosity if internal leakage is more than 50% of theoretical flow.

Total leakage is the sum of each section loss at its operating conditions

INTERNAL LEAKAGE (TYPICAL)

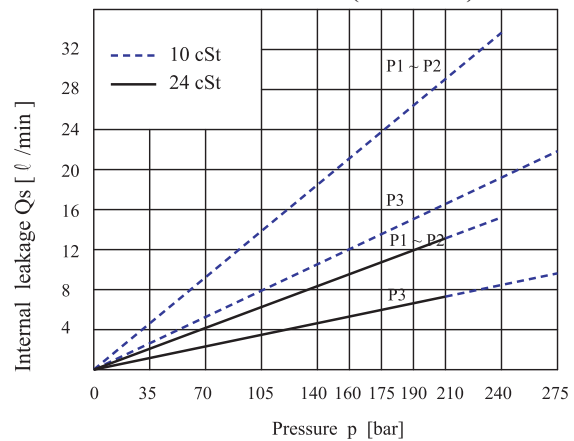

PERMISSIBLE RADIAL LOAD

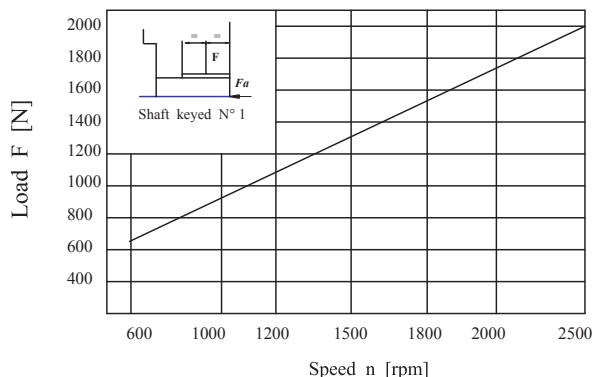



PT6DDCS Dimensional Drawing

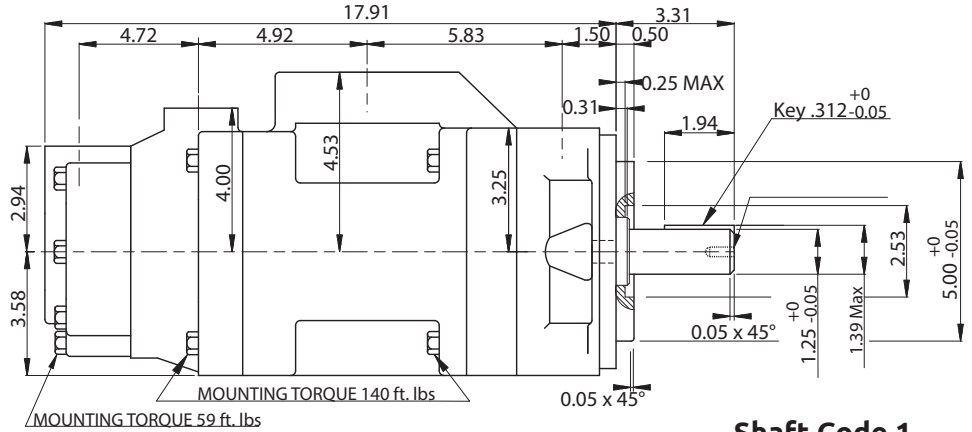
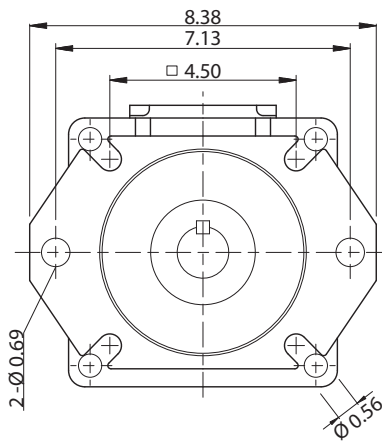

Shaft Code 1
(Keyed SAE C)

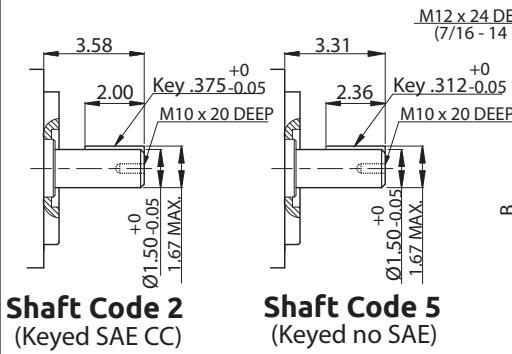

Shaft Code 2
(Keyed SAE CC)

Shaft Code 5
(Keyed no SAE)

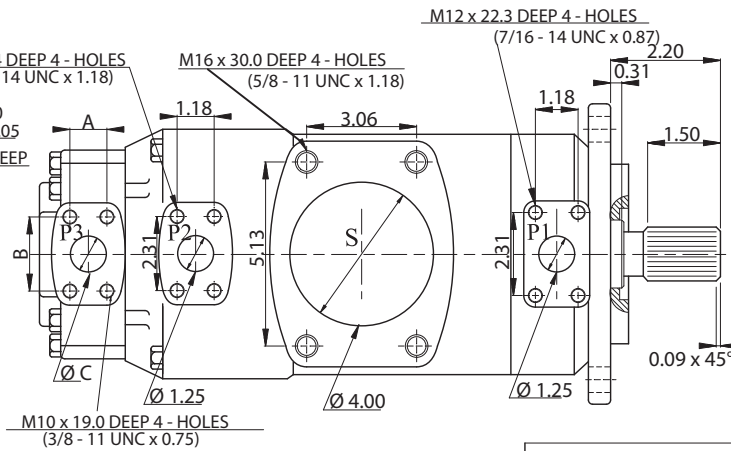

Shaft Code 3
SAE C Splined Shaft
12/24 dp. 14 teeth
30° pressure angle
Flat root side fit

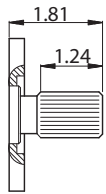

Shaft Code 5
SAE CC Splined Shaft
12/24 dp. 17 teeth
30° pressure angle
Flat root side fit

Alternate Connect Variables		
	00 & M0	01 & M1
A	1.03	0.874
B	2.06	1.874
C	1.0	0.75

Shaft torque limits in ³ /rev x PSI (cm ³ /rev x Bar)	
Shaft	Vp x p max. (P1 + P2 + P3)
1	38299 (43240)
2	63979 (72306)
3	54207 (61200)
5	49197 (55600)

PT6DDCS/PT6DDCSM OPERATING CHARACTERISTICS - TYPICAL 115 SUS (24 cSt)

Pressure Port	Series	Volumetric Displacement in ³ /rev (cm ³ /rev)	Flow qve gpm (l/min) @ 1500 RPM			Input Power HP (KW) @ 1500 RPM			P. Max PSI (Bar)	MAX RPM	
			p = 0 PSI (0 Bar)	p = 2000 PSI (140 Bar)	p = 3500 PSI (240 Bar)	p = 100 PSI (7 Bar)	p = 2000 PSI (140 Bar)	p = 3500 PSI (240 Bar)			
P1&P2	B/014	2.90 (47.6)	18.86 (71.4)	16.41 (62.1)	14.77 (55.9)	3.08 (2.3)	24.81 (18.5)	41.04 (30.6)	3500 (240)	2500	
	B/017	3.55 (58.2)	23.06 (87.3)	20.61 (78.0)	18.97 (71.8)	3.35 (2.5)	29.77 (22.2)	49.62 (37.0)			
	B/020	4.03 (66.0)	26.15 (99.0)	23.70 (89.7)	22.06 (83.5)	3.75 (2.8)	33.39 (24.9)	55.92 (41.7)			
	B/024	4.85 (79.5)	31.52 (119.3)	29.06 (110.0)	27.42 (103.8)	4.02 (3.0)	39.69 (29.6)	66.78 (49.8)			
	B/028	5.47 (89.7)	35.53 (134.5)	33.07 (125.2)	31.44 (119.0)	4.29 (3.2)	44.52 (33.2)	74.96 (55.9)			
	B/031	6.00 (98.3)	38.97 (147.5)	36.48 (138.1)	34.84 (131.9)	4.43 (3.3)	48.54 (36.2)	81.80 (61.0)			
	B/035	6.77 (111.0)	43.98 (166.5)	41.53 (157.2)	39.89 (151.0)	4.69 (3.5)	54.58 (40.7)	92.13 (68.7)			
	B/038	7.34 (120.3)	47.66 (180.4)	45.20 (171.1)	43.56 (164.9)	4.96 (3.7)	58.87 (43.9)	99.64 (74.3)			
	B/042(1)	8.30 (136.0)	53.89 (204.0)	51.43 (194.7)	49.80 (188.5)	5.36 (4.0)	66.25 (49.4)	112.24 (83.7)			
	B/045(1)	8.89 (145.7)	57.72 (218.5)	55.26 (209.2)	53.63 (203.0)	5.50 (4.1)	70.81 (52.8)	120.02 (89.5)			
B/050(1)	9.64 (158.0)	62.61 (237.0)	60.15 (227.7)	59.17 (224.0 (2)	5.90 (4.4)	76.44 (57.0)	113.99 (85.0 (2)	3062 (210)	2200		
P3	B/003	0.66 (10.8)	4.28 (16.2)	2.96 (11.2)	2.03 (7.7)	1.74 (1.3)	7.11 (5.3)	11.26 (8.4)	4010 (275)	2500	
	B/005	1.05 (17.2)	6.82 (25.8)	5.49 (20.8)	4.57 (17.3)	1.88 (1.4)	10.06 (7.5)	16.36 (12.2)			
	B/006	1.30 (21.3)	8.43 (31.9)	7.11 (26.9)	6.18 (23.4)	2.01 (1.5)	11.94 (8.9)	19.71 (14.7)			
	B/008	1.61 (26.4)	10.46 (39.6)	9.14 (34.6)	8.22 (31.1)	2.15 (1.6)	14.35 (10.7)	23.74 (17.7)			
	B/010	2.08 (34.1)	13.50 (51.1)	12.18 (46.1)	11.25 (42.6)	2.28 (1.7)	17.97 (13.4)	29.90 (22.3)			
	B/012	2.26 (37.1)	14.69 (55.6)	13.37 (50.6)	12.44 (47.1)	2.28 (1.7)	19.31 (14.4)	32.32 (24.1)			
	B/014	2.81 (46.0)	18.23 (69.0)	16.91 (64.0)	15.98 (60.5)	2.55 (1.9)	23.60 (17.6)	39.56 (29.5)			
	B/017	3.56 (58.3)	23.09 (87.4)	21.77 (82.4)	20.84 (78.9)	2.82 (2.1)	29.37 (21.9)	49.48 (36.9)			
	B/020	3.89 (63.8)	25.28 (95.7)	23.96 (90.7)	23.04 (87.2)	2.95 (2.2)	31.92 (23.8)	53.91 (40.2)			
	B/022	4.29 (70.3)	27.84 (105.4)	26.52 (100.4)	25.60 (96.9)	3.08 (2.3)	35.00 (26.1)	59.14 (44.1)			
	B/025	4.84 (79.3)	31.41 (118.9)	30.09 (113.9)	29.16 (110.4)	3.35 (2.5)	39.16 (29.2)	66.38 (49.5)			
	B/028	5.42 (88.8)	35.19 (133.2)	33.87 (128.2)	33.23 (125.8 (3)	3.75 (2.8)	43.85 (32.7)	65.04 (48.5 (3)			3062 (210)
	B/031	6.10 (100.0)	39.63 (150.0)	38.30 (145.0)	37.67 (142.6 (3)	3.75 (2.8)	48.95 (36.5)	72.95 (54.4 (3)			

(1) 042 - 045 - 050 = 2200 RPM max.

(2) 050 = 3062 PSI max. int.

(2) 028 - 031 = 3062 PSI max. int.

Min Speed : 600 RPM

PT6EDC - 066 - 038 - 008 - 1 R 00 - C 1 - P - 0 - *



① **Series** PT6EDC - ISO 250 B4 HW 4 Bolt Mount 3019-2 Flange

② **Cam Ring for "P1"**
 Volumetric displacement in³/ rev (cm³/rev)
 042 = 8.07 (132.3) 066 = 13.02 (213.3)
 045 = 8.69 (142.4) 072 = 13.86 (227.1)
 052 = 10.06 (164.8) 085 = 16.46 (269.8)
 062 = 12.00 (196.7)

Cam Ring for "P2"
 014 = 2.90 (47.6) 035 = 6.77 (111.0)
 017 = 3.55 (58.2) 038 = 7.34 (120.3)
 020 = 4.03 (66.0) 042 = 8.30 (136.0)
 024 = 4.85 (79.5) 045 = 8.89 (145.7)
 028 = 5.47 (89.7) 050 = 9.64 (158.0)
 031 = 6.00 (98.3)

Cam Ring for "P3"
 003 = 0.66 (10.8) 017 = 3.56 (58.3)
 005 = 1.05 (17.2) 020 = 3.89 (63.8)
 006 = 1.30 (21.3) 022 = 4.29 (70.3)
 008 = 1.61 (26.4) 025 = 4.84 (79.3)
 010 = 2.08 (34.1) 028 = 5.42 (88.8)
 012 = 2.26 (37.1) 031 = 6.10 (100.0)
 014 = 2.81 (46.0)

③ **Type of Shaft**
 1 = Keyed (G45N-ISO 3019-2)

④ **Rotation**
 (viewed from shaft end)
 R = clockwise
 L = counter-clockwise

⑤ **Porting Combination**
 00 = Standard

⑥ **Design Letter**
 C = Industrial
 D = Mobile

⑦ **Seal Class**
 1 = S1 HNBR (for mineral oil)
 4 = S4 EPDM (for fire resistant fluids)
 5 = S5 Viton (for mineral oil and fire resistant fluids)

⑧ **Mounting (pump)**
 P = Pedestal mounting
 F = Face mounting

⑨ **Mounting W/connection Variables**
 0 = P3 = 1" SAE
 1 = P3 = 3/4" SAE

⑩ **Modifications**

HYDROMECHANICAL POWER LOSS (TYPICAL)

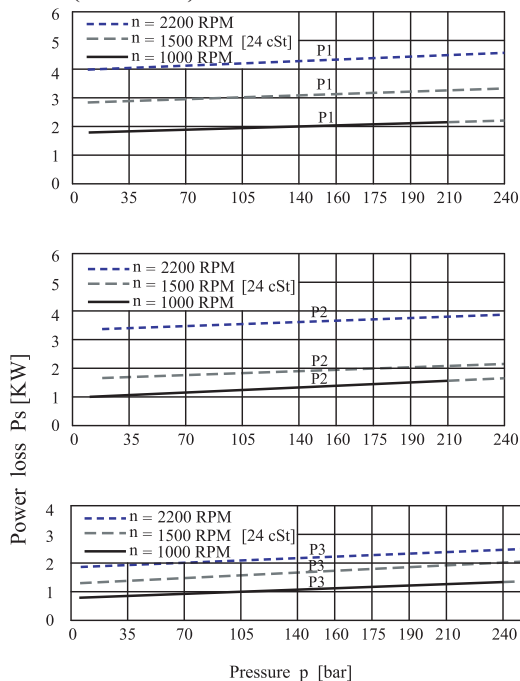

Do not operate pump more than 5 seconds at any speed or viscosity if internal leakage is more than 50% of theoretical flow.

Total leakage is the sum of each section loss at its operating conditions

INTERNAL LEAKAGE (TYPICAL)

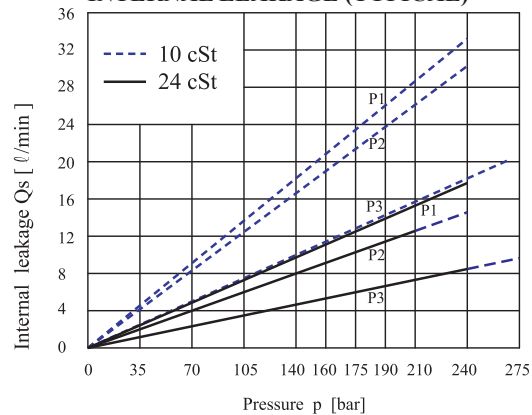

PERMISSIBLE RADIAL LOAD

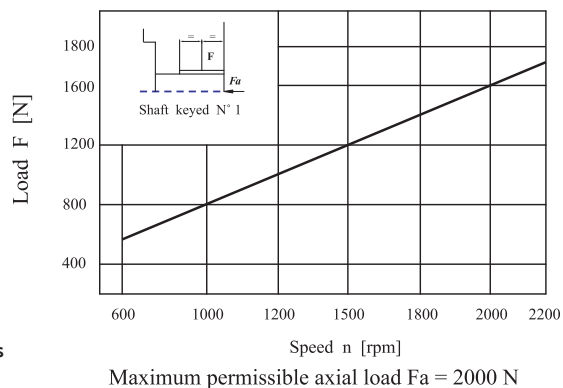



PT6EDC Dimensional Drawing

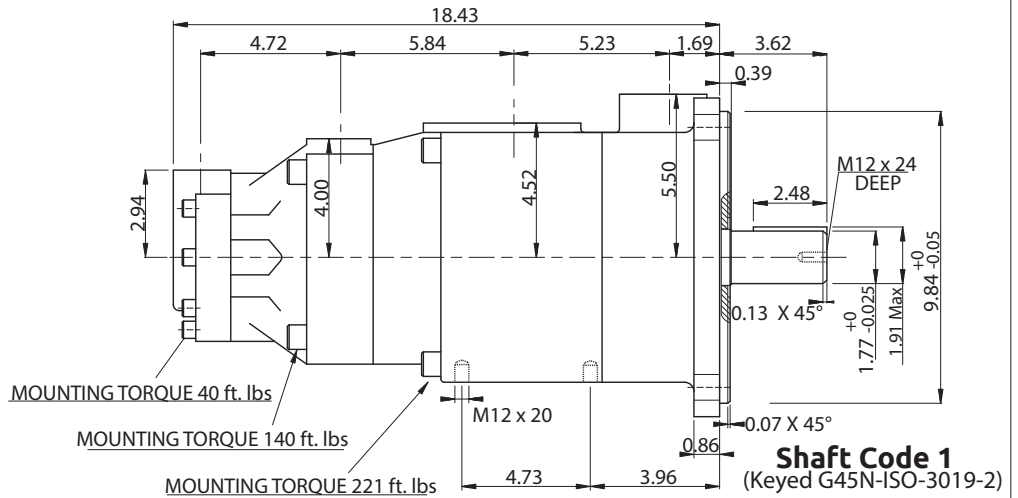
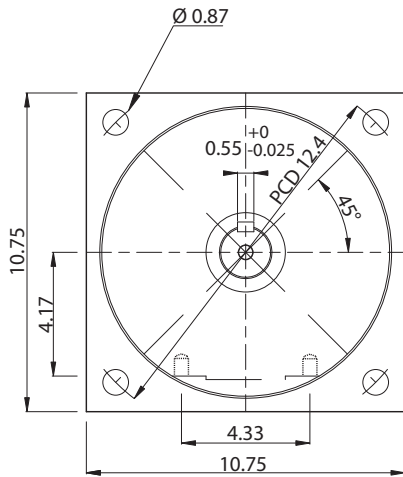

PORT	CODE	A	B	C
P3	0	2.06	1.03	1.00
	1	1.874	0.874	0.75

Shaft torque limits in ³ /rev x PSI (cm ³ /rev x Bar)	
Shaft	Vp x p max. (P1+P2+P3)
1	101506 (114715)

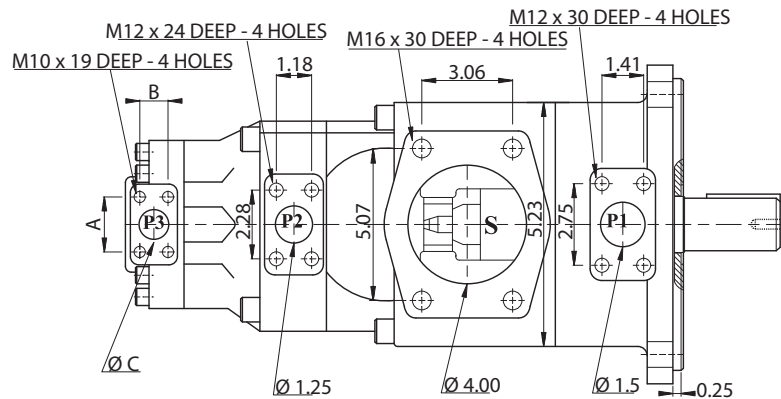

PT6EDC OPERATING CHARACTERISTICS - TYPICAL 115 SUS (24 cSt)

Pressure Port	Series	Volumetric Displacement in ³ /rev (cm ³ /rev)	Flow Q in GPM (l/min) @ 1500 RPM			Input Power HP (KW) @ 1500 RPM			P. Max PSI (Bar)	MAX RPM
			p = 0 PSI (0 Bar)	p = 2000 PSI (140 Bar)	p = 3500 PSI (240 Bar)	p = 100 PSI (7 Bar)	p = 2000 PSI (140 Bar)	p = 3500 PSI (240 Bar)		
P1	042	8.07 (132.3)	52.44 (198.5)	49.80 (188.5)	47.89 (181.3)	1.37 (5.2)	13.05 (49.4)	21.82 (82.6)	3500 (240)	2200
	045	8.69 (142.4)	56.43 (213.6)	53.79 (203.6)	51.91 (196.5)	1.43 (5.4)	13.97 (52.9)	23.43 (88.7)		
	052	10.06 (164.8)	65.30 (247.2)	62.66 (237.2)	60.79 (230.1)	1.53 (5.8)	16.06 (60.8)	26.97 (102.1)		
	062	12.00 (196.7)	77.93 (295.0)	75.29 (285.0)	73.41 (277.9)	1.69 (6.4)	18.99 (71.9)	32.04 (121.3)		
	066	13.02 (213.3)	84.51 (319.9)	81.87 (309.9)	79.99 (302.8)	1.77 (6.7)	20.53 (77.7)	34.66 (131.2)		
	072	13.86 (227.1)	89.98 (340.6)	87.34 (330.6)	85.46 (323.5)	1.82 (6.9)	21.82 (82.6)	36.85 (139.5)		
	085(1)	16.46 (269.8)	106.91 (404.7)	105.06 (397.7 (2))	()	1.93 (7.3)	17.25 (65.3 (2))	()	1450 (100)	2000
P2	014	2.90 (47.6)	18.86 (71.4)	16.41 (62.1)	14.77 (55.9)	3.08 (2.3)	24.81 (18.5)	41.04 (30.6)	3500 (240)	2200
	017	3.55 (58.2)	23.06 (87.3)	20.61 (78.0)	18.97 (71.8)	3.35 (2.5)	29.77 (22.2)	49.62 (37.0)		
	020	4.03 (66.0)	26.15 (99.0)	23.70 (89.7)	22.06 (83.5)	3.75 (2.8)	33.39 (24.9)	55.92 (41.7)		
	024	4.85 (79.5)	31.52 (119.3)	29.06 (110.0)	27.42 (103.8)	4.02 (3.0)	39.69 (29.6)	66.78 (49.8)		
	028	5.47 (89.7)	35.53 (134.5)	33.07 (125.2)	31.44 (119.0)	4.29 (3.2)	44.52 (33.2)	74.96 (55.9)		
	031	6.00 (98.3)	38.97 (147.5)	36.48 (138.1)	34.84 (131.9)	4.43 (3.3)	48.54 (36.2)	81.80 (61.0)		
	035	6.77 (111.0)	43.98 (166.5)	41.53 (157.2)	39.89 (151.0)	4.69 (3.5)	54.58 (40.7)	92.13 (68.7)		
	038	7.34 (120.3)	47.66 (180.4)	45.20 (171.1)	43.56 (164.9)	4.96 (3.7)	58.87 (43.9)	99.64 (74.3)		
	042(3)	8.30 (136.0)	53.89 (204.0)	51.43 (194.7)	49.80 (188.5)	5.36 (4.0)	66.25 (49.4)	112.24 (83.7)		
	045(3)	8.89 (145.7)	57.72 (218.5)	55.26 (209.2)	53.63 (203.0)	5.50 (4.1)	70.81 (52.8)	120.02 (89.5)		
	050(3)	9.64 (158.0)	62.61 (237.0)	60.15 (227.7)	59.17 (224.0 (4))	5.90 (4.4)	76.44 (57.0)	113.99 (85.0 (4))	3062 (210)	2200
P3	003	0.66 (10.8)	4.28 (16.2)	2.96 (11.2)	2.04 (7.7)	1.74 (1.3)	7.11 (5.3)	11.22 (8.4)	4010 (275)	2200
	005	1.05 (17.2)	6.82 (25.8)	5.49 (20.8)	4.57 (17.3)	1.88 (1.4)	10.06 (7.5)	16.36 (12.2)		
	006	1.30 (21.3)	8.43 (31.9)	7.11 (26.9)	6.18 (23.4)	2.01 (1.5)	11.94 (8.9)	19.71 (14.7)		
	008	1.61 (26.4)	10.46 (39.6)	9.14 (34.6)	8.22 (31.1)	2.15 (1.6)	14.35 (10.7)	23.74 (17.7)		
	010	2.08 (34.1)	13.50 (51.1)	12.18 (46.1)	11.25 (42.6)	2.28 (1.7)	17.97 (13.4)	29.90 (22.3)		
	012	2.26 (37.1)	14.69 (55.6)	13.37 (50.6)	12.44 (47.1)	2.28 (1.7)	19.31 (14.4)	32.32 (24.1)		
	014	2.81 (46.0)	18.23 (69.0)	16.91 (64.0)	15.98 (60.5)	2.55 (1.9)	23.60 (17.6)	39.56 (29.5)		
	017	3.56 (58.3)	23.09 (87.4)	21.77 (82.4)	20.84 (78.9)	2.82 (2.1)	29.37 (21.9)	49.48 (36.9)		
	020	3.89 (63.8)	25.28 (95.7)	23.96 (90.7)	23.04 (87.2)	2.95 (2.2)	31.92 (23.8)	53.91 (40.2)		
	022	4.29 (70.3)	27.84 (105.4)	26.52 (100.4)	25.60 (96.9)	3.08 (2.3)	35.00 (26.1)	59.14 (44.1)		
	025	4.84 (79.3)	31.41 (118.9)	30.09 (113.9)	29.16 (110.4)	3.35 (2.5)	39.16 (29.2)	66.38 (49.5)		
	028	5.42 (88.8)	35.19 (133.2)	33.87 (128.2)	33.23 (125.8 (4))	3.75 (2.8)	43.85 (32.7)	65.04 (48.5 (4))		
	031	6.10 (100.0)	39.63 (150.0)	38.30 (145.0)	37.67 (142.6 (4))	3.75 (2.8)	48.95 (36.5)	72.95 (54.4 (4))		

(1) 085 = 2000 RPM max.
(3) 042 - 045 - 050 = 2200 RPM max.

(2) 085 = 1087 PSI max. 085 = 1305 PSI max. int.
(4) 028 - 031 - 050 = 3062 PSI max.

Min Speed : 600 RPM

PT67DCB - 038 - 022 - B08 - 1 R 00 - A 1 - M *

① P1 P2 P3 ③ ④ ⑤ ⑥ ⑦ ⑧ ⑨

① **Series** PT67DCB - SAE-C 2-Bolt Mount

② **Cam Ring for "P1"**

Volumetric displacement in $\frac{3}{4}$ rev (cm³/rev)

014 = 2.90 (47.6)	035 = 6.77 (111.0)
017 = 3.55 (58.2)	038 = 7.34 (120.3)
020 = 4.03 (66.0)	042 = 8.30 (136.0)
024 = 4.85 (79.5)	045 = 8.89 (145.7)
028 = 5.47 (89.7)	050 = 9.64 (158.0)
031 = 6.00 (98.3)	

Cam Ring for "P2"

003 = 0.66 (10.8)	017 = 3.56 (58.3)
005 = 1.05 (17.2)	020 = 3.89 (63.8)
006 = 1.30 (21.3)	022 = 4.29 (70.3)
008 = 1.61 (26.4)	025 = 4.84 (79.3)
010 = 2.08 (34.1)	028 = 5.42 (88.8)
012 = 2.26 (37.1)	031 = 6.10 (100.0)
014 = 2.81 (46.0)	

Cam Ring for "P3"

B02 = 0.35 (5.7)	B09 = 1.71 (28.0)
B03 = 0.60 (9.8)	B10 = 1.94 (31.8)
B04 = 0.78 (12.8)	B11 = 2.13 (34.9)
B05 = 0.97 (15.9)	B12 = 2.50 (40.9)
B06 = 1.21 (19.8)	B14 = 2.75 (45.1)
B07 = 1.37 (22.5)	B15 = 3.05 (50.0)
B08 = 1.52 (24.9)	

③ **Type of Shaft**
 1 = Keyed (No SAE)
 2 = Keyed (SAE CC)
 3 = Splined (SAE C)
 4 = Splined (SAE CC)

④ **Rotation**
 (viewed from shaft end)
 R= clockwise
 L= counter-clockwise

⑤ **Porting Combination**
 00=Standard

⑥ **Design Letter**

⑦ **Seal Class**
 1= S1 HNBR (for mineral oil)
 4= S4 EPDM (for fire resistant fluids)
 5= S5 Viton (for mineral oil and fire resistant fluids)

⑧ **Mounting W/connection variables**

P1 = 1 1/4" P2 = 1" P3 = 3/4" S = 4"	
Unc	Metric
01	M1

⑨ **Modifications**

HYDROMECHANICAL POWER LOSS (TYPICAL)

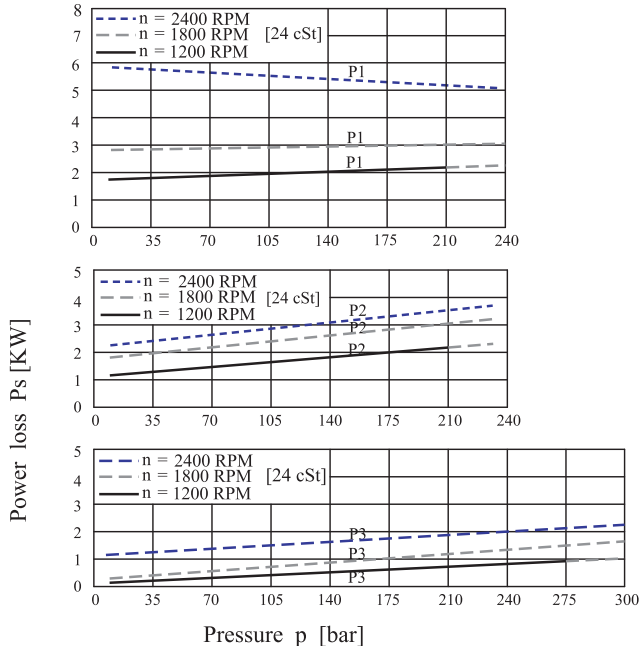

Do not operate pump more than 5 seconds at any speed or viscosity if internal leakage is more than 50% of theoretical flow.

Total leakage is the sum of each section loss at its operating conditions

INTERNAL LEAKAGE (TYPICAL)

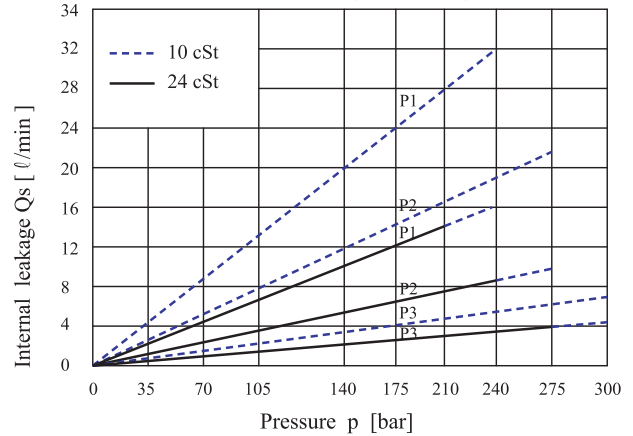

PERMISSIBLE RADIAL LOAD

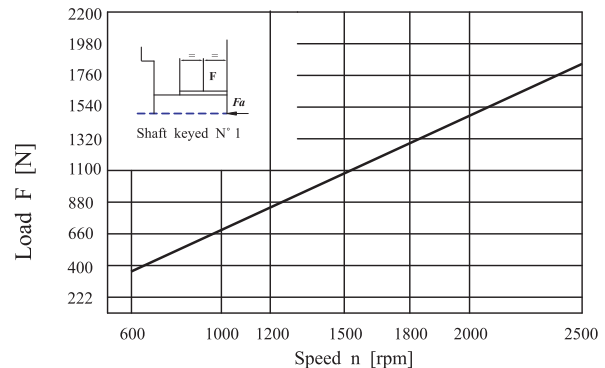

Maximum permissible axial load Fa = 800 N



PT67DCB Dimensional Drawing

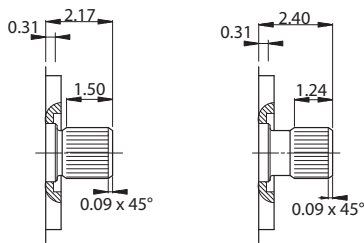
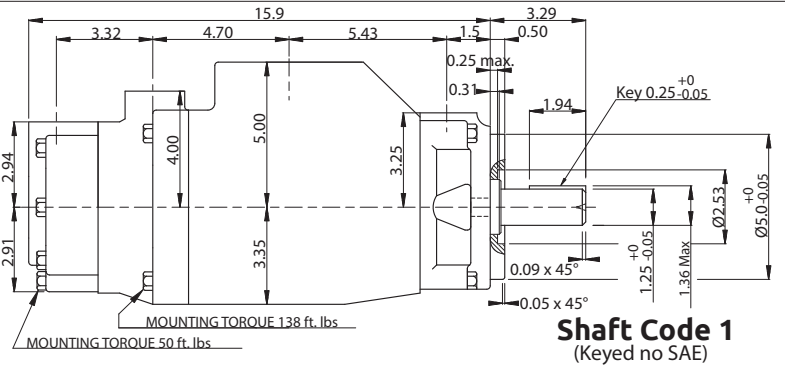
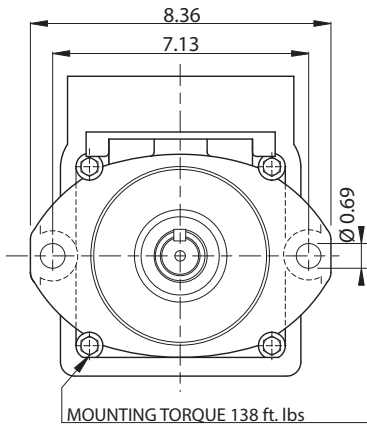

Shaft Code 3
SAE C Splined Shaft
12/24 dp. 14 teeth
30° pressure angle
Flat root side fit

Shaft Code 4
SAE CC Splined Shaft
12/24 dp. 17 teeth
30° pressure angle
Flat root side fit

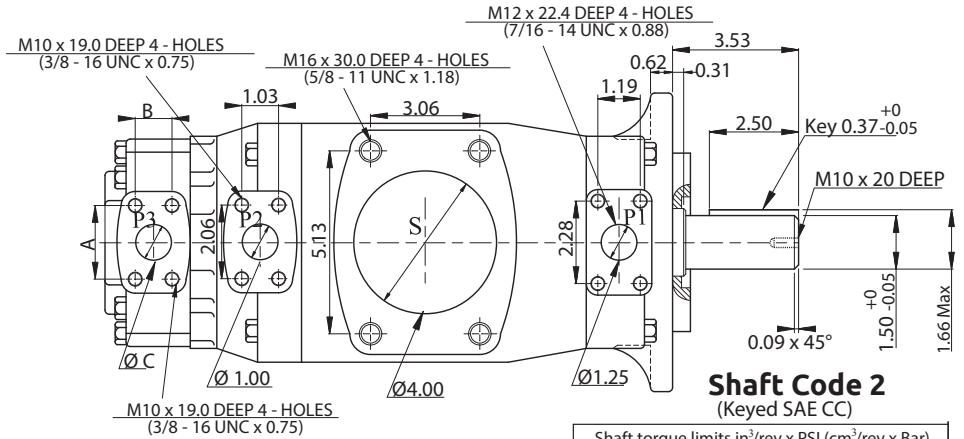

Shaft torque limits in ³ /rev x PSI (cm ³ /rev x Bar)		
Pump	Shaft	Vp x p max
PT67DCB	1	38299 (43240)
	2	58901 (66500)
	3	54027 (61200)
	4	58901 (66500)

PT67DCB OPERATING CHARACTERISTICS - TYPICAL 115 SUS (24 cSt)

Pressure Port	Series	Volumetric Displacement in ³ /rev (cm ³ /rev)	Flow Q in GPM (l/min) @ 1800 RPM				Input Power HP (KW) @ 1800 RPM			P. Max PSI (Bar)	MAX RPM
			p = 0 PSI (0 Bar)	p = 2000 PSI (140 Bar)	p = 3500 PSI (240 Bar)	p = 100 PSI (7 Bar)	p = 2000 PSI (140 Bar)	p = 3500 PSI (240 Bar)			
P1	014	2.90 (47.6)	22.45 (85.0)	20.45 (77.4)	18.78 (71.1)	4.01 (2.99)	28.94 (21.85)	9.72 (36.79)	3500 (240)	2500	
	017	3.55 (58.2)	23.06 (87.3)	20.61 (78.0)	18.97 (71.8)	3.35 (2.50)	29.77 (22.20)	49.62 (37.00)			
	020	4.03 (66.0)	31.33 (118.6)	26.79 (101.4)	27.53 (104.2)	4.53 (3.38)	39.52 (29.47)	13.24 (50.11)			
	024	4.85 (79.5)	37.72 (142.8)	35.56 (134.6)	33.95 (128.5)	4.91 (3.66)	47.02 (35.06)	80.31 (59.89)			
	028	5.47 (89.7)	42.61 (161.3)	40.42 (153.0)	38.78 (146.8)	5.19 (3.87)	52.68 (39.28)	90.22 (67.28)			
	031	6.00 (98.3)	46.68 (176.7)	44.51 (168.5)	42.88 (162.3)	5.48 (4.09)	57.45 (42.84)	98.58 (73.51)			
	035	6.77 (111.0)	52.73 (199.6)	50.54 (191.3)	48.63 (184.1)	5.78 (4.31)	64.49 (48.09)	110.90 (82.70)			
	038	7.34 (120.3)	57.14 (216.3)	54.97 (208.1)	53.31 (201.8)	6.03 (4.50)	69.65 (51.94)	111.94 (83.47)			
	042(1)	8.30 (136.0)	64.59 (244.5)	62.42 (236.3)	60.79 (230.1)	6.48 (4.83)	78.37 (58.44)	135.19 (100.81)			
	045(1)	8.89 (145.7)	69.19 (261.9)	67.02 (253.7)	65.38 (247.5)	6.73 (5.02)	83.75 (62.45)	144.60 (107.83)			
050(1)	9.64 (158.0)	75.05 (284.1)	72.86 (275.8)	71.67 (271.3 (2))	7.07 (5.27)	90.57 (67.54)	134.53 (100.32 (2))				
P2	003	0.66 (10.8)	5.18 (19.6)	3.86 (14.6)	()	2.11 (1.57)	8.45 (6.30)	()	4010 (275)	2500	
	005	1.05 (17.2)	8.16 (30.9)	6.87 (26.0)	5.68 (21.5)	2.28 (1.70)	11.99 (8.94)	19.81 (14.77)			
	006	1.30 (21.3)	10.12 (38.3)	8.82 (33.4)	7.61 (28.8)	2.39 (1.78)	14.27 (10.64)	23.79 (17.74)			
	008	1.61 (26.4)	12.52 (47.4)	11.25 (42.6)	10.01 (37.9)	2.53 (1.89)	17.10 (12.75)	28.74 (21.43)			
	010	2.08 (34.1)	16.19 (61.3)	14.90 (56.4)	13.68 (51.8)	2.76 (2.06)	21.38 (15.94)	36.21 (27.00)			
	012	2.26 (37.1)	17.62 (66.7)	16.33 (61.8)	15.11 (57.2)	2.83 (2.11)	23.04 (17.18)	39.13 (29.18)			
	014	2.81 (46.0)	21.85 (82.7)	20.55 (77.8)	19.34 (73.2)	3.08 (2.30)	27.99 (20.87)	47.77 (35.62)			
	017	3.56 (58.3)	27.69 (104.8)	26.39 (99.9)	25.18 (95.3)	3.42 (2.55)	34.80 (25.95)	59.73 (44.54)			
	020	3.89 (63.8)	30.30 (114.7)	29.01 (109.8)	27.79 (105.2)	3.57 (2.66)	37.86 (28.23)	65.07 (48.52)			
	022	4.29 (70.3)	33.39 (126.4)	32.10 (121.5)	30.88 (116.9)	3.75 (2.80)	41.46 (30.92)	71.37 (53.22)			
P3	025(3)	4.84 (79.3)	37.64 (142.5)	36.35 (137.6)	35.16 (133.1)	4.01 (2.99)	46.45 (34.64)	80.11 (59.74)	4375 (300)	2500	
	028(3)	5.42 (88.8)	42.16 (159.6)	40.87 (154.7)	40.26 (152.4 (4))	4.26 (3.18)	38.33 (38.58)	76.73 (57.22 (4))			
	031(3)	6.10 (100.0)	47.47 (179.7)	46.20 (174.9)	45.57 (172.5 (4))	4.57 (3.41)	57.95 (43.21)	86.05 (64.17 (4))			
	Series	in ³ /rev (cm ³ /rev)	p = 0 PSI (0 Bar)	p = 2000 PSI (140 Bar)	p = 4375 PSI (300 Bar)	p = 100 PSI (7 Bar)	p = 2000 PSI (140 Bar)	p = 4375 PSI (300 Bar)			
B02	0.35 (5.7)	2.75 (10.4)	2.32 (8.8)	1.80 (6.8)	0.74 (0.55)	4.01 (2.99)	8.58 (6.40)				
B03	0.60 (9.8)	4.65 (17.6)	4.20 (15.9)	3.70 (14.0)	0.84 (0.63)	6.24 (4.65)	13.75 (10.25)				
B04	0.78 (12.8)	6.08 (23.0)	5.65 (21.4)	5.12 (19.4)	0.94 (0.70)	7.90 (5.89)	17.61 (13.13)				
B05	0.97 (15.9)	7.56 (28.6)	7.11 (26.9)	6.60 (25.0)	1.02 (0.76)	9.62 (7.17)	21.62 (16.12)				
B06	1.21 (19.8)	9.40 (35.6)	8.96 (33.9)	8.45 (32.0)	1.13 (0.84)	11.79 (8.79)	26.66 (19.88)				
B07	1.37 (22.5)	10.67 (40.4)	10.25 (38.8)	9.72 (36.8)	1.19 (0.89)	13.29 (9.91)	30.13 (22.47)				
B08	1.52 (24.9)	11.81 (44.7)	11.39 (43.1)	10.86 (41.1)	1.26 (0.94)	14.62 (10.90)	33.23 (24.78)				
B09	1.71 (28.0)	13.29 (50.3)	12.84 (48.6)	12.42 (47.0)	1.35 (1.01)	16.35 (12.19)	37.24 (27.77)				
B10	1.94 (31.8)	15.11 (57.2)	14.66 (55.5)	14.13 (53.5)	1.49 (1.11)	18.44 (13.75)	42.13 (31.42)				
B11	2.13 (34.9)	16.62 (62.9)	16.17 (61.2)	15.67 (59.3)	1.54 (1.15)	20.17 (15.04)	43.21 (32.22)				
B12	2.50 (40.9)	19.47 (73.7)	19.05 (72.1)	18.52 (70.1)	1.72 (1.28)	23.55 (17.56)	50.57 (37.71)				
B14	2.75 (45.1)	21.35 (80.8)	20.92 (79.2)	20.34 (77.0)	1.82 (1.36)	25.79 (19.23)	55.48 (41.37)				
B15	3.05 (50.0)	23.72 (89.8)	23.33 (88.3)	22.85 (86.5 (5))	1.97 (1.47)	28.54 (21.28)	57.34 (42.76 (5))				

(1) 042 - 045 - 050 = 2200 RPM max.

(2) 050 = 3062 PSI max. int.

(4) 028 - 031 = 3062 PSI max. int.

(3) 025 - 028 - 031 = 2500 RPM max.

(5) B15 = 4083 PSI max. int.

Min Speed : 600 RPM

PT6CR/PT6CRM * - **025 -1 R 00 - A 10 - A 1..**

① ② ③ ④ ⑤ ⑥ ⑦ ⑧ ⑨ ⑩ ⑪ ⑫

① **Series** PT6CR/PT6CRM - SAE-B 2-Bolt Mount

② **Y-Metric port connection, Omit for UNC**

③ **Cam Ring**

Volumetric displacement in ³/rev (cm³/rev)

003/B03 = 0.66 (10.8)	017/B17 = 3.56 (58.3)
005/B05 = 1.05 (17.2)	020/B20 = 3.89 (63.8)
006/B06 = 1.30 (21.3)	022/B22 = 4.29 (70.3)
008/B08 = 1.61 (26.4)	025/B25 = 4.84 (79.3)
010/B10 = 2.08 (34.1)	028/B28 = 5.42 (88.8)
012/B12 = 2.26 (37.1)	031/B31 = 6.10 (100.0)
014/B14 = 2.81 (46.0)	

④ **Type of Shaft**

1 = Keyed (SAE BB)	2 = Keyed (No SAE)
3 = Splined (SAE B)	4 = Splined (SAE BB)
5 = Keyed (No SAE)	

⑤ **Rotation**

(viewed from shaft end)

R= clockwise

L= counter-clockwise

⑥ **Porting Combination**

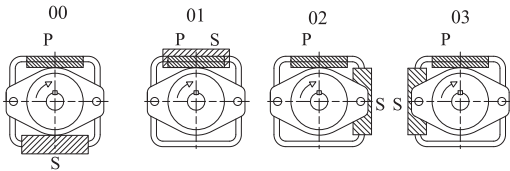

⑦ **Adapter**

0 = None B = SAE B
A = SAE A C = SAE C

⑧ **Coupling**

1 = SAE A 4 = SAE C
2 = SAE B 5 = SAE J498b
3 = SAE BB 16/32- 11 tooth

⑨ **Porting Adapter**

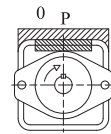

SAE A
SAE B
SAE C

⑩ **Design Letter**

⑪ **Seal Class**

1= S1 HNBR (for mineral oil)
4= S4 EPDM (for fire resistant fluids)
5= S5 Viton (for mineral oil and fire resistant fluids)

⑫ **Modifications**

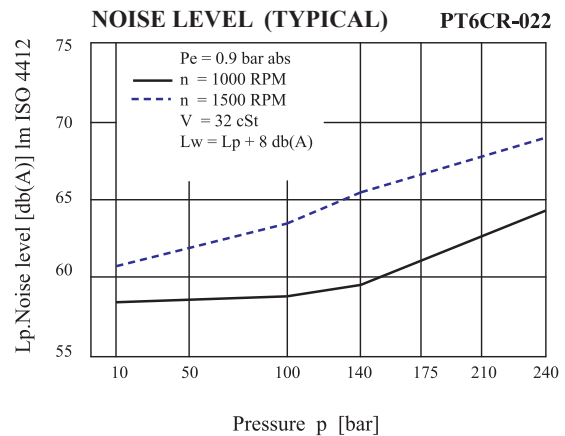
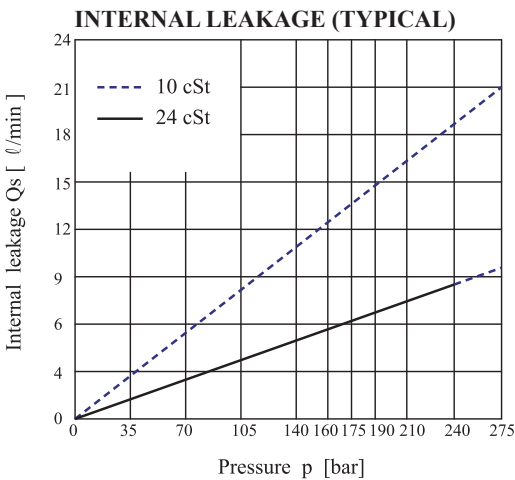

Do not operate pump more than 5 seconds at any speed or viscosity if internal leakage is more than 50% of theoretical flow.

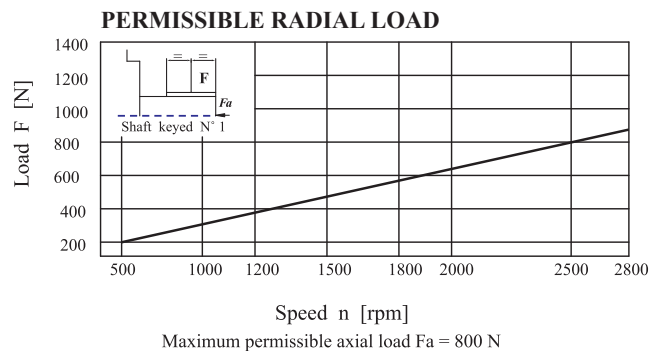
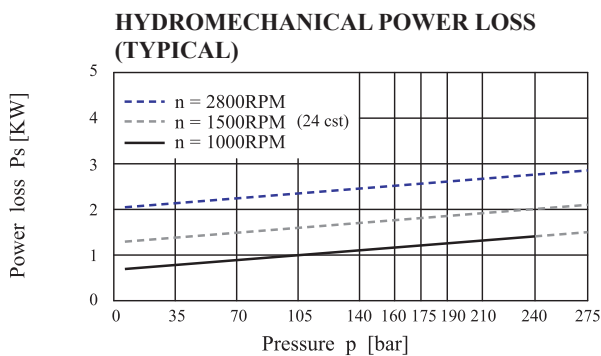



PT6CR Dimensional Drawing

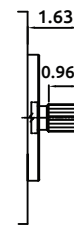
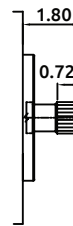
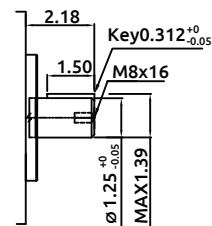
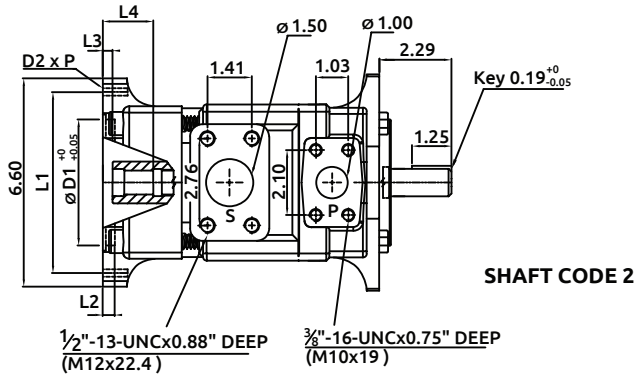
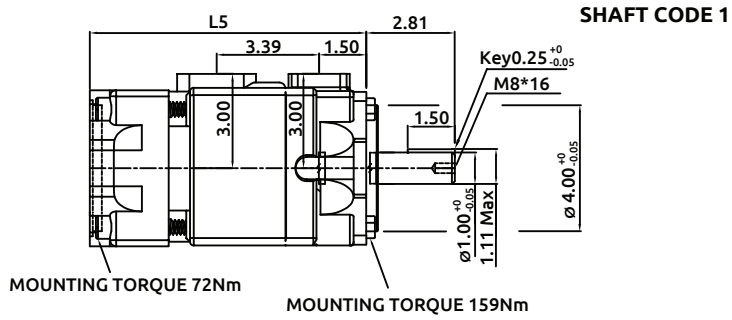
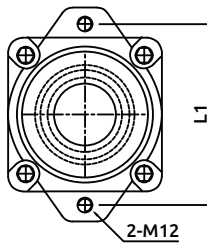
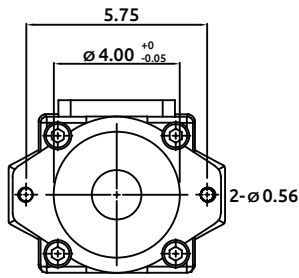

Shaft torque limits(ml/rev x bar)				
Pump	Shaft	Vp x p max	Coupling drive	Vp x p max
PT6CR	1	21420	SAE A	11000
	2	14300	SAE B	20600
	3	20600	SAE BB	22050
	4	32670	SAE C	22050
	5	34180	SAE 11 teeth	15850

Adapter	SAE A			SAE B	
	SAE A	SAE 11 teeth	SAE B	SAE B	SAE BB
Coupling drive	9	11	13	13	15
Number of teeth	16/32	16/32	16/32	16/32	16/32
Pitch	30°	30°	30°	30°	30°
Pressure angle	0.625	0.75	0.875	0.875	1.00
Major dia.(min)	0.500	0.63	0.875	0.875	0.877
Minor dia.(min)					

Adapter	D1	D2	P	L1	L2	L3	L4	L5
SAE A	3.25	M10	0.95	4.19	0.28	0.31	1.26	8.23
SAE B	4.00	M12	1.10	5.75	0.38	0.31	1.81	8.78

SHAFT CODE 5

SHAFT CODE 4
SAE BB splined shaft
Class 1-J498b 16/32 d.p.
-15 teeth
30° pressure angle flat
root side fit

SHAFT CODE 3
SAE B splined shaft
Class 1-J498b 16/32 d.p.
-13 teeth
30° pressure angle flat
root side fit

PT6CR/PT6CRM OPERATING CHARACTERISTICS - TYPICAL 115 Sus (24 cSt)

Pressure Port	Series	Volumetric Displacement Vp in ³ /rev (cm ³ /rev)	Flow qve gpm (l/min) @ 1500 rpm			Input Power HP (KW) @ 1500 rpm			P. Max psi (bar)	MAX RPM		
			p = 0 psi (0 bar)	p = 2000 psi (140 bar)	p = 3500 psi (240 bar)	p = 100 psi (7 bar)	p = 2000 psi (140 bar)	p = 3500 psi (240 bar)				
P1	B/003	0.66 (10.8)	4.28 (16.2)	2.96 (11.2)	2.03 (7.7)	1.74 (1.3)	7.11 (5.3)	11.26 (8.4)	4010 (275)	2800		
	B/005	1.05 (17.2)	6.82 (25.8)	5.49 (20.8)	4.57 (17.3)	1.88 (1.4)	10.06 (7.5)	16.36 (12.2)				
	B/006	1.30 (21.3)	8.43 (31.9)	7.11 (26.9)	6.18 (23.4)	2.01 (1.5)	11.94 (8.9)	19.71 (14.7)				
	B/008	1.61 (26.4)	10.46 (39.6)	9.14 (34.6)	8.22 (31.1)	2.15 (1.6)	14.35 (10.7)	23.74 (17.7)				
	B/010	2.08 (34.1)	13.50 (51.1)	12.18 (46.1)	11.25 (42.6)	2.28 (1.7)	17.97 (13.4)	29.90 (22.3)				
	B/012	2.26 (37.1)	14.69 (55.6)	13.37 (50.6)	12.44 (47.1)	2.28 (1.7)	19.31 (14.4)	32.32 (24.1)				
	B/014	2.81 (46.0)	18.23 (69.0)	16.91 (64.0)	15.98 (60.5)	2.55 (1.9)	23.60 (17.6)	39.56 (29.5)				
	B/017	3.56 (58.3)	23.09 (87.4)	21.77 (82.4)	20.84 (78.9)	2.82 (2.1)	29.37 (21.9)	49.48 (36.9)				
	B/020	3.89 (63.8)	25.28 (95.7)	23.96 (90.7)	23.04 (87.2)	2.95 (2.2)	31.92 (23.8)	53.91 (40.2)				
	B/022	4.29 (70.3)	27.84 (105.4)	26.52 (100.4)	25.60 (96.9)	3.08 (2.3)	35.00 (26.1)	59.14 (44.1)				
	B/025 ⁽¹⁾	4.84 (79.3)	31.41 (118.9)	30.09 (113.9)	29.16 (110.4)	3.35 (2.5)	39.16 (29.2)	66.38 (49.5)			3062 (210)	2500
	B/028 ⁽¹⁾	5.42 (88.8)	35.19 (133.2)	33.87 (128.2)	33.23 (125.8)	3.75 (2.8)	43.85 (32.7)	65.04 (48.5)				
	B/031 ⁽¹⁾	6.10 (100.0)	39.63 (150.0)	38.30 (145.0)	37.67 (142.6)	3.75 (2.8)	48.95 (36.5)	72.95 (54.4)				

(1) 025 - 028 - 031 = 2500 R.P.M. max.

(2) 028 - 031 = 210 bar max. int.

Min Speed : 600 rpm



PT6DR Ordering Code

PT6DR/PT6DRM * - 045 - 1 R 00 - A 1 0 - A 1 ..

① ② ③ ④ ⑤ ⑥ ⑦ ⑧ ⑨ ⑩ ⑪ ⑫

① **Series** PT6DR/PT6DRM - SAE-C 2-Bolt Mount

② **Y-Metric port connection, Omit for UNC**

③ **Cam Ring**

Volumetric displacement in³/ rev (cm³/rev)

014/B14 = 2.90 (47.6) 035/B35 = 6.77 (111.0)

017/B17 = 3.55 (58.2) 038/B38 = 7.34 (120.3)

020/B20 = 4.03 (66.0) 042/B42 = 8.30 (136.0)

024/B24 = 4.85 (79.5) 045/B45 = 8.89 (145.7)

028/B28 = 5.47 (89.7) 050/B50 = 9.64 (158.0)

031/B31 = 6.00 (98.3)

④ **Type of Shaft**

1 = Keyed (SAE C)

2 = Keyed (SAE CC)

3 = Splined (SAE C)

5 = Keyed (No SAE)

⑤ **Rotation**

(viewed from shaft end)

R = clockwise

L = counter-clockwise

⑥ **Porting Combination**

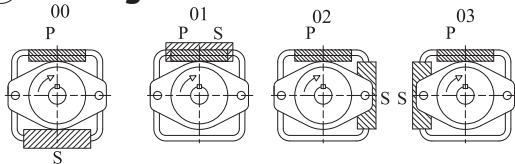

⑦ **Adapter**

0 = None

B = SAE B

A = SAE A

C = SAE C

⑧ **Coupling**

1 = SAE A

4 = SAE C

2 = SAE B

5 = SAE J498b

3 = SAE BB

16/32- 11 tooth

⑨ **Porting Adapter**

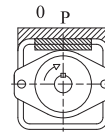

SAE A

SAE B

SAE C

⑩ **Design Letter**

⑪ **Seal Class**

1 = S1 HNBR (for mineral oil)

4 = S4 EPDM (for fire resistant fluids)

5 = S5 Viton (for mineral oil and fire resistant fluids)

⑫ **Modifications**

INTERNAL LEAKAGE (TYPICAL)

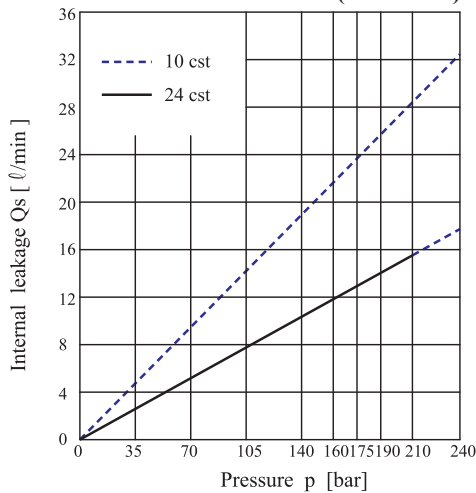

Do not operate pump more than 5 seconds at any speed or viscosity if internal leakage is more than 50% of theoretical flow.

HYDROMECHANICAL POWER LOSS (TYPICAL)

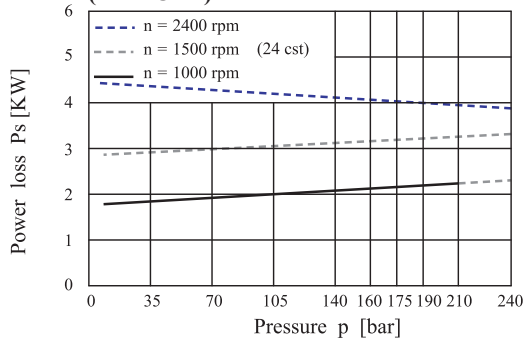

NOISE LEVEL (TYPICAL) PT6DR-038

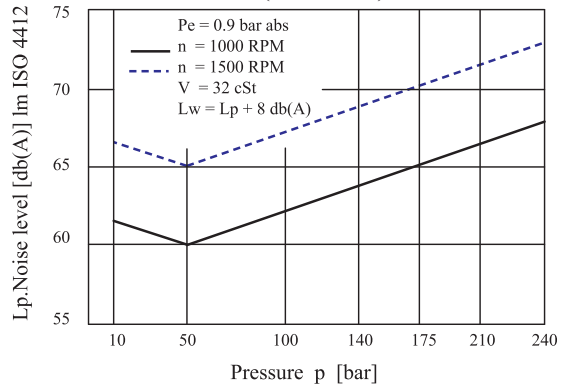

PERMISSIBLE RADIAL LOAD

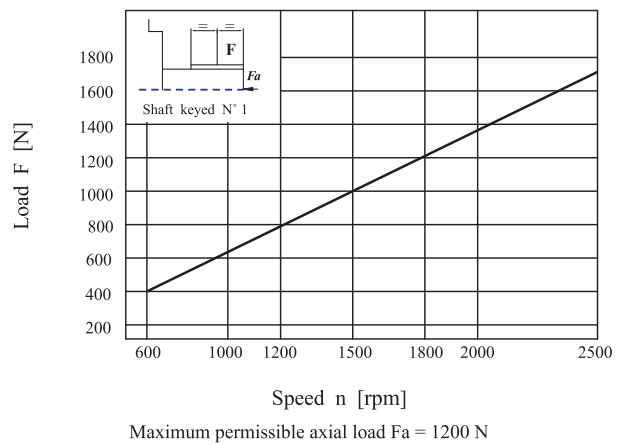

Maximum permissible axial load Fa = 1200 N



PT6DR Dimensional Drawing

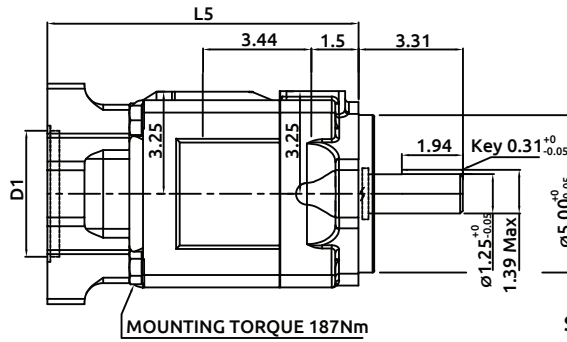
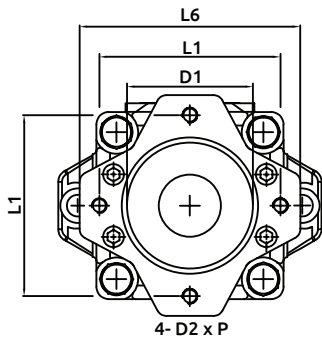
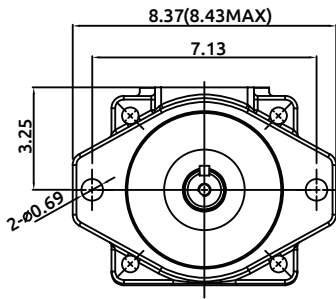

SHAFT CODE 1

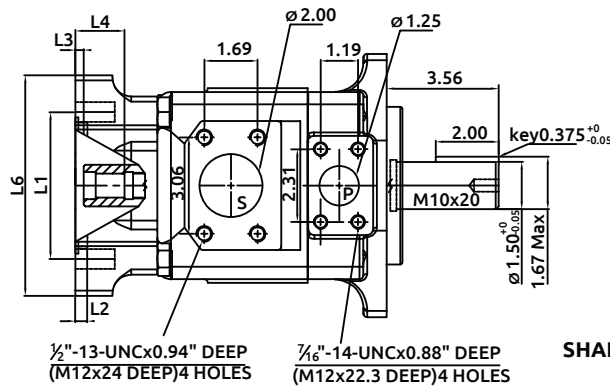

SHAFT CODE 2

Shaft torque limits (ml/rev x bar)			
Shaft	V x p max.	Coupling drive	V x p max.
1	43240	SAE A	11000
2	66036	SAE B	20600
3	61200	SAE BB	32670
5	55600	SAE C	37390
		SAE -11 teeth	15850

Adapter	SAE A			SAE B		SAE C
	SAE A	SAE 11 teeth	SAE B	SAE B	SAE BB	SAE C
Coupling drive	SAE A	SAE 11 teeth	SAE B	SAE B	SAE BB	SAE C
Number of teeth	9	11	13	13	15	14
Pitch	16/32	16/32	16/32	16/32	16/32	12/24
Pressure angle	30°	30°	30°	30°	30°	30°
Major dia.(min)	.625	.750	0.875	0.875	1.00	1.25
Minor dia.(min)	.500	.630	0.753	0.753	0.88	1.09

Adaptor	D1	D2	P	L1	L2	L3	L4	L5	L6
SAE A	3.25	M10	.94	4.19	.28	.315	1.26	9.33	7.00
SAE B	4.00	M12	1.1	5.75	.38	.315	1.81	9.88	7.00
SAE C	5.00	M16	-	7.13	.50	.315	2.20	10.28	8.50

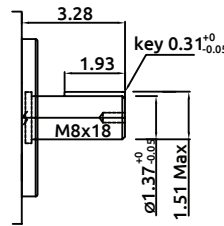

SHAFT CODE 5

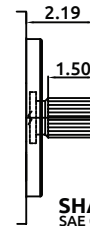

SHAFT CODE 3
SAE C splined shaft
Class 1-J498b 12/24
d.p. -14 teeth 30°
pressure angle flat root
side fit

PT6DR/PT6DRM OPERATING CHARACTERISTICS - TYPICAL 115 Sus (24 cst)

Series	Volumetric Displacement Vp in ³ /rev (cm ³ /rev)	Flow qve gpm (l/min) @ 1500 rpm			Input Power HP (KW) @ 1500 rpm			P. Max psi (bar)	MAX RPM
		p = 0 psi (0 bar)	p = 2000 psi (140 bar)	p = 3500 psi (240 bar)	p = 100 psi (7 bar)	p = 2000 psi (140 bar)	p = 3500 psi (240 bar)		
B/014	2.90 (47.6)	18.86 (71.4)	16.41 (62.1)	14.77 (55.9)	3.08 (2.3)	24.81 (18.5)	41.04 (30.6)	3500 (240)	2500
B/017	3.55 (58.2)	23.06 (87.3)	20.61 (78.0)	18.97 (71.8)	3.35 (2.5)	29.77 (22.2)	49.62 (37.0)		
B/020	4.03 (66.0)	26.15 (99.0)	23.70 (89.7)	22.06 (83.5)	3.75 (2.8)	33.39 (24.9)	55.92 (41.7)		
B/024	4.85 (79.5)	31.52 (119.3)	29.06 (110.0)	27.42 (103.8)	4.02 (3.0)	39.69 (29.6)	66.78 (49.8)		
B/028	5.47 (89.7)	35.53 (134.5)	33.07 (125.2)	31.44 (119.0)	4.29 (3.2)	44.52 (33.2)	74.96 (55.9)		
B/031	6.00 (98.3)	38.94 (147.5)	36.48 (138.1)	34.84 (131.9)	4.43 (3.3)	48.54 (36.2)	81.80 (61.0)		
B/035	6.77 (111.0)	43.98 (166.5)	41.53 (157.2)	39.89 (151.0)	4.69 (3.5)	54.58 (40.7)	92.13 (68.7)		
B/038	7.34 (120.3)	47.66 (180.4)	45.20 (171.1)	43.56 (164.9)	4.96 (3.7)	58.87 (43.9)	99.64 (74.3)		
B/042 (1)	8.30 (136.0)	53.89 (204.0)	51.43 (194.7)	49.80 (188.5)	5.36 (4.0)	66.25 (49.4)	112.24 (83.7)		
B/045 (1)	8.89 (145.7)	57.72 (218.5)	55.26 (209.2)	53.63 (203.0)	5.50 (4.1)	70.81 (52.8)	120.02 (89.5)		
B/050 (1)	9.64 (158.0)	62.61 (237.0)	60.15 (227.7)	59.17 (224.0 (2)	5.90 (4.4)	76.44 (57.0)	113.99 (85.0 (2)	3063 (210)	2200

(1) 042 - 045 -050 = 2200 R.P.M. max.

(2) 050 = 210 bar max. int.

Min Speed : 600 rpm



PT6ER Ordering Code

PT6ER/PT6ERM * - **066** - **1** **R** **00** - **A** **10** - **A** **1** ..

① ② ③ ④ ⑤ ⑥ ⑦ ⑧ ⑨ ⑩ ⑪ ⑫

- ① **Series** PT6ER/PT6ERM - SAE-C 2-Bolt Mount
- ② **Y- Metric port connection, Omit for UNC**
- ③ **Cam Ring**
Volumetric displacement in ³/ rev (cm³/rev)
042 = 8.07 (132.3) 062 = 12.00 (196.7)
045 = 8.69 (142.4) 066 = 13.02 (213.3)
050 = 9.67 (158.5) 072 = 13.86 (227.1)
052 = 10.06 (164.8) 085 = 16.46 (269.8)
- ④ **Type of Shaft**
1 = Keyed (SAE CC)
3 = Splined (SAE C)
4 = Splined (SAE CC)
- ⑤ **Rotation**
(viewed from shaft end)
R= clockwise
L= counter-clockwise
- ⑥ **Porting Combination**

- ⑦ **Adapter**
0 = None B = SAE B
A = SAE A C = SAE C
- ⑧ **Coupling**
1 = SAE A 4 = SAE C
2 = SAE B 5 = SAE J498b
3 = SAE BB 16/32- 11 tooth

- ⑨ **Porting Adapter**

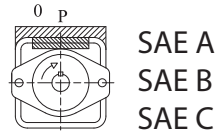

- ⑩ **Design Letter**
- ⑪ **Seal Class**
1= S1 HNBR (for mineral oil)
4= S4 EPDM (for fire resistant fluids)
5= S5 Viton (for mineral oil and fire resistant fluids)
- ⑫ **Modifications**

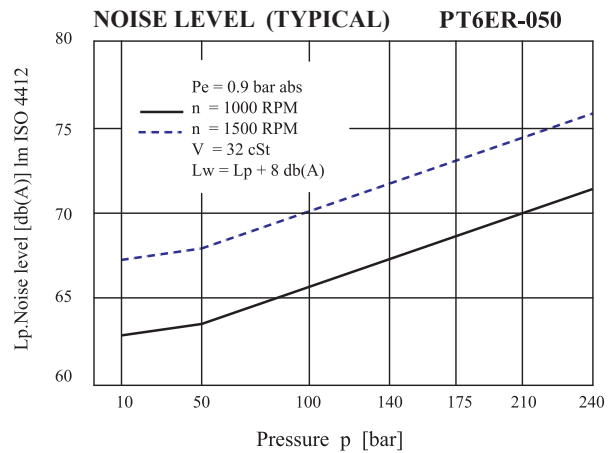
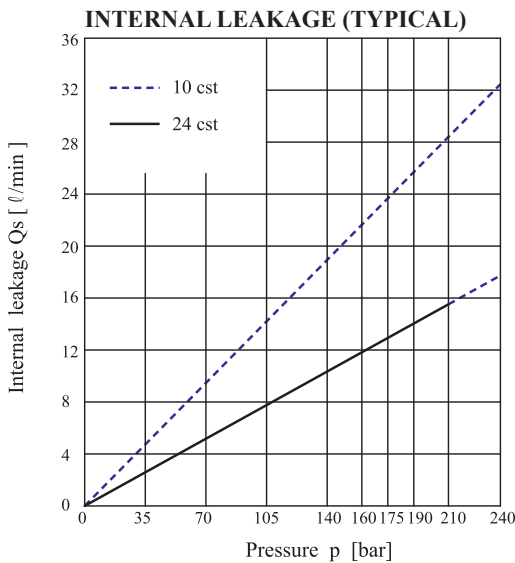
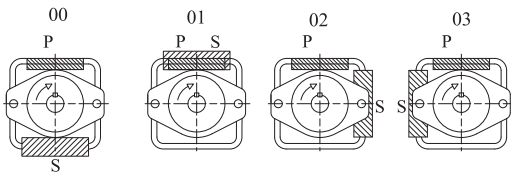

Do not operate pump more than 5 seconds at any speed or viscosity if internal leakage is more than 50% of theoretical flow.

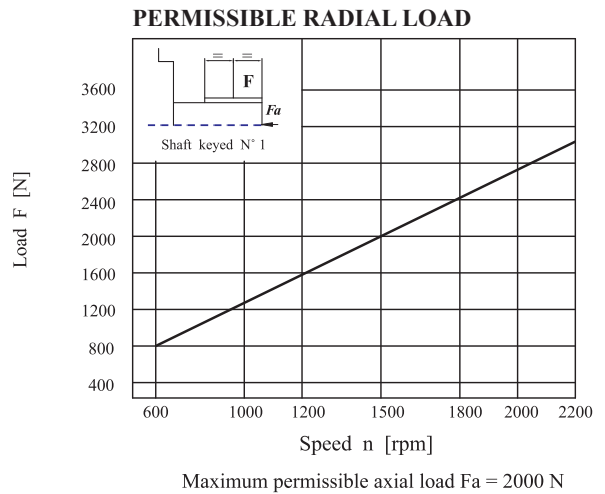
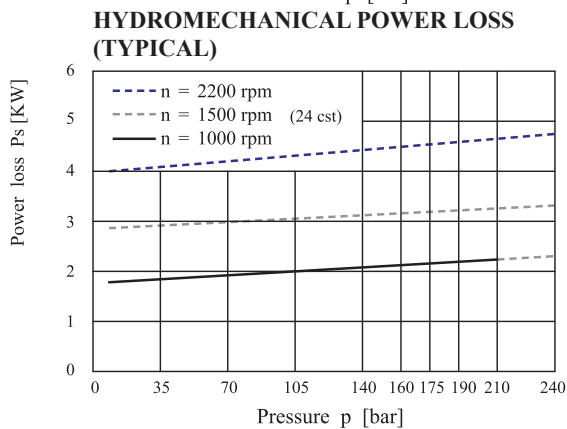



PT6ER Dimensional Drawing

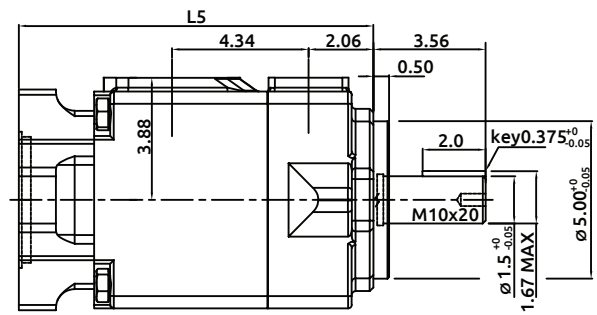
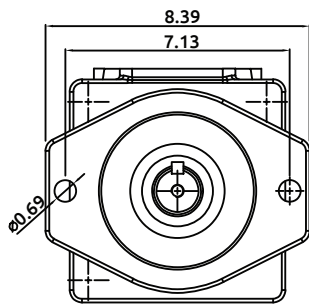

SHAFT CODE 1

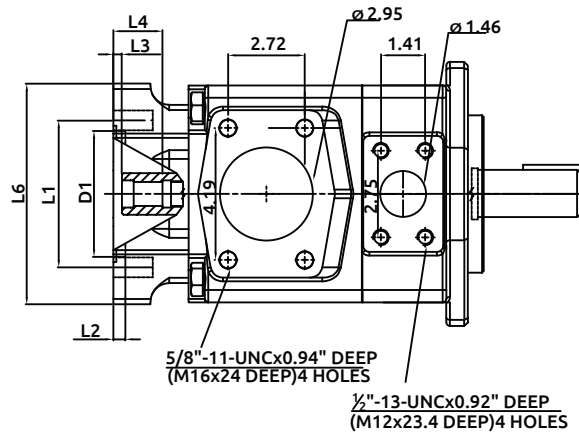
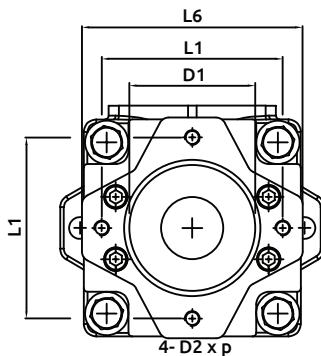

Shaft torque limits (m/rev x bar)			
Shaft	V x p max.	Coupling drive	V x p max.
1	43240	SAE A	11000
2	66036	SAE B	20600
3	61200	SAE BB	32670
5	55600	SAE C	37390
		SAE -11 teeth	15850

Adapter	SAE A			SAE B		SAE C
Coupling drive	SAE A	SAE 11 teeth	SAE B	SAE B	SAE BB	SAE C
Number of teeth	9	11	13	13	15	14
Pitch	16/32	16/32	16/32	16/32	16/32	12/24
Pressure angle	30°	30°	30°	30°	30°	30°
Major dia.(min)	.625	0.75	0.875	0.875	1.00	1.25
Minor dia.(min)	.500	0.63	0.875	0.753	0.88	1.09

Adaptor	D1	D2	P	L1	L2	L3	L4	L5	L6
SAE A	3.25	M10	0.94	4.19	0.28	.315	1.26	9.33	7.0
SAE B	4.00	M12	1.10	5.75	0.38	.315	1.81	9.88	7.0
SAE C	5.00	M16	-	7.13	0.50	.315	2.20	10.28	8.5

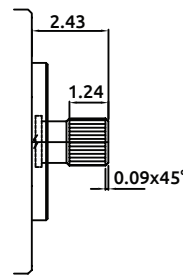

SHAFT CODE 4
SAE CC splined shaft
Class 1-J498b 12/24 d.p.
-17 teeth
30° pressure angle flat
root side fit

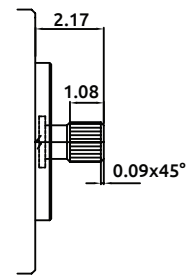

SHAFT CODE 3
SAE C splined shaft
Class 1-J498b 12/24 d.p.
-14 teeth
30° pressure angle flat
root side fit

PT6ER/PT6ERM OPERATING CHARACTERISTICS - TYPICAL 115 Sus (24 cSt)

Series	Volumetric Displacement Vp in ³ /rev (cm ³ /rev)	Flow qve gpm (l/min) @ 1500 rpm			Input Power HP (KW) @ 1500 rpm			P. Max psi (bar)	MAX RPM
		p = 0 psi (0 bar)	p = 2000 psi (140 bar)	p = 3500 psi (240 bar)	p = 100 psi (7 bar)	p = 2000 psi (140 bar)	p = 3500 psi (240 bar)		
B/042	8.07 (132.3)	52.44 (198.5)	49.80 (188.5)	47.89 (181.3)	6.97 (5.2)	66.25 (49.4)	110.77 (82.6)	3500 (240)	2200
B/045	8.69 (142.4)	56.43 (213.6)	53.79 (203.6)	51.91 (196.5)	7.24 (5.4)	70.94 (52.9)	118.95 (88.7)		
B/050	9.67 (158.5)	62.79 (237.7)	60.15 (227.7)	58.28 (220.6)	7.64 (5.7)	78.45 (58.5)	131.82 (98.3)		
B/052	10.06 (164.8)	65.30 (247.2)	62.66 (237.2)	60.79 (230.1)	7.78 (5.8)	81.53 (60.8)	136.92 (102.1)		
B/062	12.00 (196.7)	77.93 (295.0)	75.29 (285.0)	73.41 (277.9)	8.58 (6.4)	96.42 (71.9)	162.67 (121.3)		
B/066	13.02 (213.3)	84.51 (319.9)	81.87 (309.9)	79.99 (302.8)	8.98 (6.7)	104.20 (77.7)	175.94 (131.2)		
B/072	13.86 (227.1)	89.98 (340.6)	87.34 (330.6)	85.46 (323.5)	9.25 (6.9)	110.77 (82.6)	187.07 (139.5)		
B/085 (1)(2)	16.46 (269.8)	106.91 (404.7)	105.06 (397.7)	()	9.79 (7.3)	87.57 (65.3)	()	1450 (100)	2000

(1) 085 = 2000 rpm max.

(2) 085 = 75 bar cont. 085 = 90 bar max.int

Min Speed : 600 rpm



PT6DRS Ordering Code

PT6DRS/PT6DRSM - 045 - 1 R 00 - A 1 0 - A 1 ..
 ① ② ③ ④ ⑤ ⑥ ⑦ ⑧ ⑨ ⑩ ⑪

① **Series** PT6DRS/PT6DRSM - SAE-C 2 & 4 Bolt Mount

② **Cam Ring**
 Volumetric displacement in³/rev (cm³/rev)
 014/B14 = 2.90 (47.6) 035/B35 = 6.77 (111.0)
 017/B17 = 3.55 (58.2) 038/B38 = 7.34 (120.3)
 020/B20 = 4.03 (66.0) 042/B42 = 8.30 (136.0)
 024/B24 = 4.85 (79.5) 045/B45 = 8.89 (145.7)
 028/B28 = 5.47 (89.7) 050/B50 = 9.64 (158.0)
 031/B31 = 6.00 (98.3)

③ **Type of Shaft**
 1 = Keyed (SAE C)
 2 = Keyed (SAE CC)
 3 = Splined (SAE C)
 5 = Keyed (No SAE)

④ **Rotation**
 (viewed from shaft end)
 R = clockwise
 L = counter-clockwise

⑤ **Porting Combination**

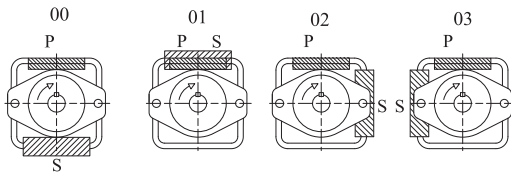

⑥ **Adapter**
 0 = None B = SAE B
 A = SAE A C = SAE C

⑦ **Coupling**
 1 = SAE A 4 = SAE C
 2 = SAE B 5 = SAE J498b
 3 = SAE BB 16/32- 11 teeth

⑧ **Porting Adapter**

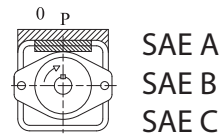

⑨ **Design Letter**

⑩ **Seal Class**
 1 = S1 (for mineral oil)
 4 = S4 (for fire resistant fluids)
 3 = S5 (for mineral oil and fire resistant fluids)

⑪ **Modification**

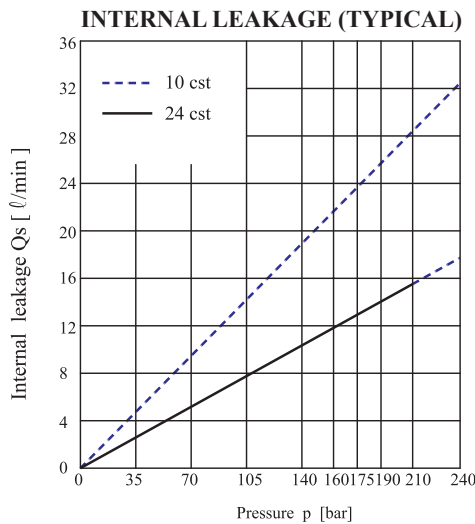

Do not operate pump more than 5 seconds at any speed or viscosity if internal leakage is more than 50% of theoretical flow.

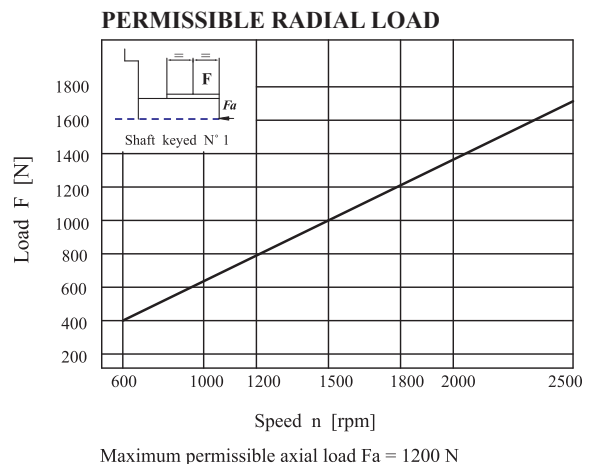
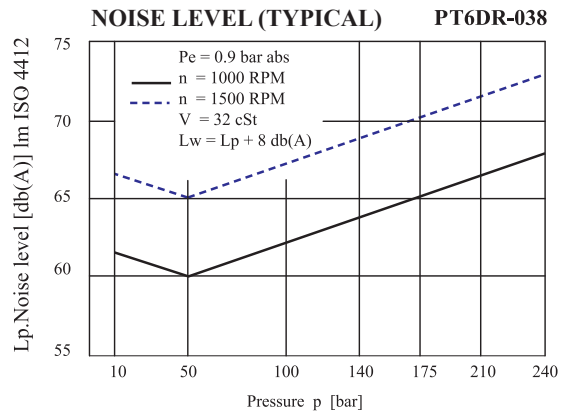
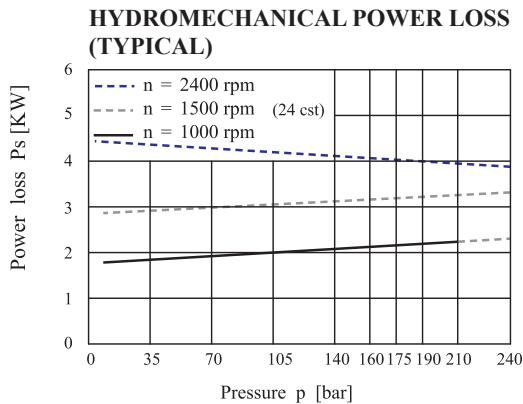

Maximum permissible axial load Fa = 1200 N



PT6DRS Dimensional Drawing

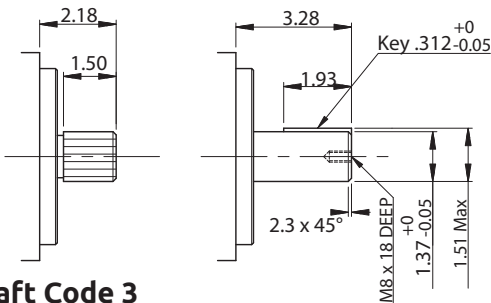
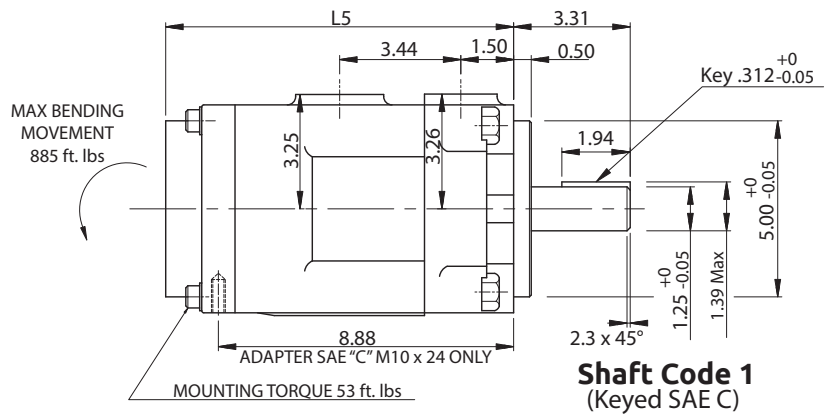
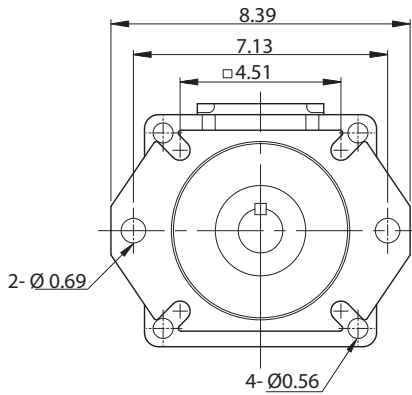

Shaft Code 3
SAE C Splined Shaft
12/24 dp. -14 teeth
30° pressure angle
Flat root side fit

Shaft Code 5
(Keyed no SAE)

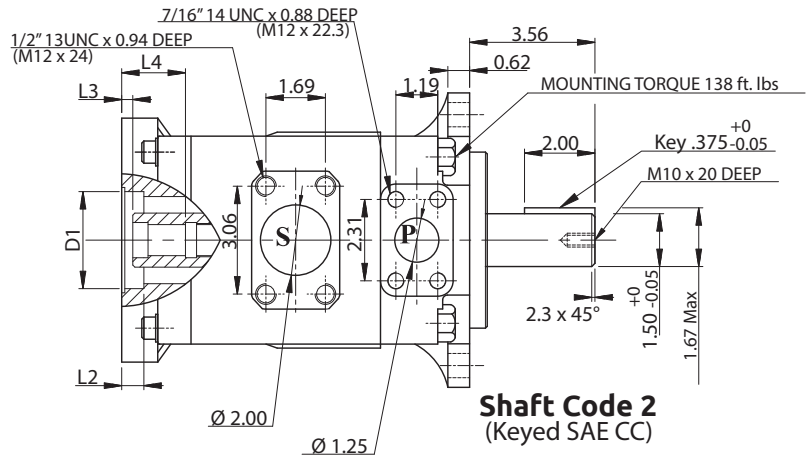

Shaft Code 2
(Keyed SAE CC)

Shaft torque limits in ³ /rev x PSI (cm ³ /rev x Bar)			
Shaft	V x p max.	Coupling Drive	V x p max.
1	38300 (43240)	SAE A	9743 (11000)
2	58491 (66036)	SAE B	18246 (20600)
3	54207 (61200)	SAE BB	28937 (32670)
5	49247 (55600)	SAE C	33118 (37390)
		SAE - 11 teeth	14039 (15850)

Adapter	SAE "A"			SAE "B"		SAE "C"
	Coupling Drive	SAE A	SAE 11 Teeth	SAE B	SAE BB	SAE C
Number of Teeth	9	11	13	13	15	14
Pitch	16/32	16/32	16/32	16/32	16/32	12/24
Pressure Angle	30°	30°	30°	30°	30°	30°
Major Dia. (min)	15.875	19.05	22.225	22.225	25.400	31.750
Minor Dia. (min)	12.700	16.00	19.134	19.134	22.268	27.585

Adapter	D1	D2	P	L1	L2	L3	L4	L5
SAE A	3.25	M10	0.94	4.19	0.43	0.31	1.26	9.3
SAE B	4.00	M12	1.10	5.75	0.63	0.31	1.81	9.9
SAE C	5.00	M16	--	7.13	0.63	0.31	2.20	10.3

PT6DRS/PT6DRSM OPERATING CHARACTERISTICS - TYPICAL 115 SUS (24 cst)

Series	Volumetric Displacement in ³ /rev (cm ³ /rev)	Flow qve gpm (l/min) @ 1500 RPM			Input Power HP (KW) @ 1500 RPM			P. Max PSI (Bar)	MAX RPM
		p = 0 PSI (0 Bar)	p = 2000 PSI (140 Bar)	p = 3500 PSI (240 Bar)	p = 100 PSI (7 Bar)	p = 2000 PSI (140 Bar)	p = 3500 PSI (240 Bar)		
B/014	2.90 (47.6)	18.86 (71.4)	16.41 (62.1)	14.77 (55.9)	3.08 (2.3)	24.81 (18.5)	41.04 (30.6)	3500 (240)	2500
B/017	3.55 (58.2)	23.06 (87.3)	20.61 (78.0)	18.97 (71.8)	3.35 (2.5)	29.77 (22.2)	49.62 (37.0)		
B/020	4.03 (66.0)	26.15 (99.0)	23.70 (89.7)	22.06 (83.5)	3.75 (2.8)	33.39 (24.9)	55.92 (41.7)		
B/024	4.85 (79.5)	31.52 (119.3)	29.06 (110.0)	27.42 (103.8)	4.02 (3.0)	39.69 (29.6)	66.78 (49.8)		
B/028	5.47 (89.7)	35.53 (134.5)	33.07 (125.2)	31.44 (119.0)	4.29 (3.2)	44.52 (33.2)	74.96 (55.9)		
B/031	6.00 (98.3)	38.94 (147.4)	36.48 (138.1)	34.84 (131.9)	4.43 (3.3)	48.54 (36.2)	81.80 (61.0)		
B/035	6.77 (111.0)	43.98 (166.5)	41.53 (157.2)	39.89 (151.0)	4.69 (3.5)	54.58 (40.7)	92.13 (68.7)		
B/038	7.34 (120.3)	47.66 (180.4)	45.20 (171.1)	43.56 (164.9)	4.96 (3.7)	58.87 (43.9)	99.64 (74.3)		
B/042 ₍₁₎	8.30 (136.0)	53.89 (204.0)	51.43 (194.7)	49.80 (188.5)	5.36 (4.0)	66.25 (49.4)	112.24 (83.7)	3062 (210)	2200
B/045 ₍₁₎	8.89 (145.7)	57.72 (218.5)	55.26 (209.2)	53.63 (203.0)	5.50 (4.1)	70.81 (52.8)	120.02 (89.5)		
B/050 ₍₁₎	9.64 (158.0)	62.61 (237.0)	60.15 (227.7)	59.17 (224.0) (2)	5.90 (4.4)	76.44 (57.0)	113.99 (85.0) (2)		

(1) 042 -045 - 050 = 2200 RPM max.

(2) 050 = 3062 PSI max. int.

min speed : 600 RPM

PT6DRSS/PT6DRSSM -045 - 1 R 00 -A 1 0 - A 1 ..

① **Series**
PT6DRSS/PT6DRSSM - SAE-C 4-Bolt Mount

② **Cam Ring**
Volumetric displacement in³/ rev (cm³/rev)
014/B14 = 2.90 (47.6) 035/B35 = 6.77 (111.0)
017/B17 = 3.55 (58.2) 038/B38 = 7.34 (120.3)
020/B20 = 4.03 (66.0) 042/B42 = 8.30 (136.0)
024/B24 = 4.85 (79.5) 045/B45 = 8.89 (145.7)
028/B28 = 5.47 (89.7) 050/B50 = 9.64 (158.0)
031/B31 = 6.00 (98.3)

③ **Type of Shaft**
1 = Keyed (SAE C)
2 = Keyed (SAE CC)
3 = Splined (SAE C)
5 = Keyed (No SAE)

④ **Direction of Rotation**
(viewed from shaft end)
R = Clockwise
L = Counter-clockwise

⑤ **Porting Combination**

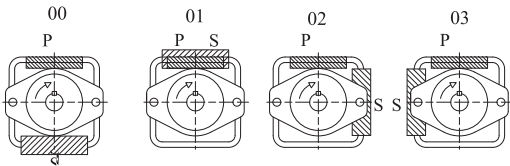

⑥ **Adapter**
0 = None B = SAE B
A = SAE A C = SAE C

⑦ **Coupling**
1 = SAE A 4 = SAE C
2 = SAE B 5 = SAE J498b
3 = SAE BB 16/32 - 11 teeth

⑧ **Porting Adapter**

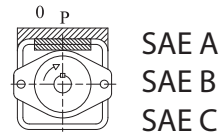

⑨ **Design Letter**

⑩ **Seal Class**
1 = S1 (for mineral oil)
4 = S4 (for fire resistant fluid)
5 = S5 (for mineral oil & fire resistant fluid)

⑪ **Modification**

INTERNAL LEAKAGE (TYPICAL)

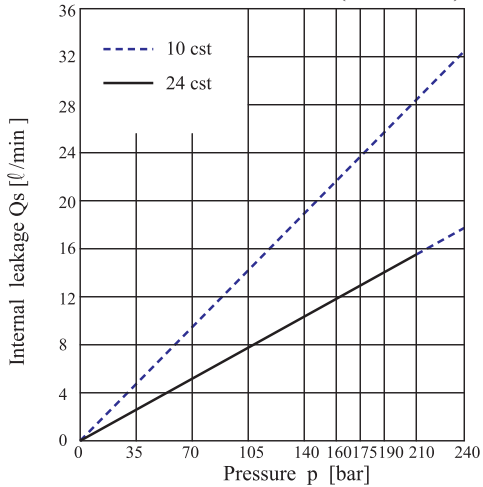

Do not operate pump more than 5 seconds at any speed or viscosity if internal leakage is more than 50% of theoretical flow.

HYDROMECHANICAL POWER LOSS (TYPICAL)

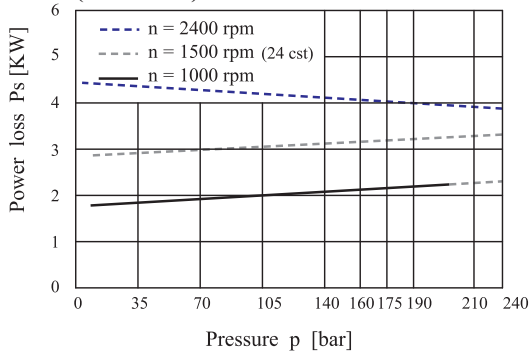

NOISE LEVEL (TYPICAL) PT6DR-038

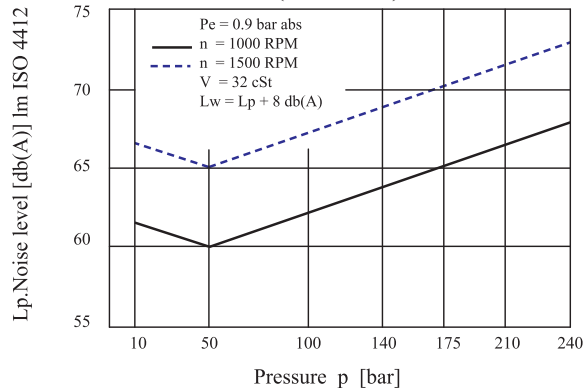

PERMISSIBLE RADIAL LOAD

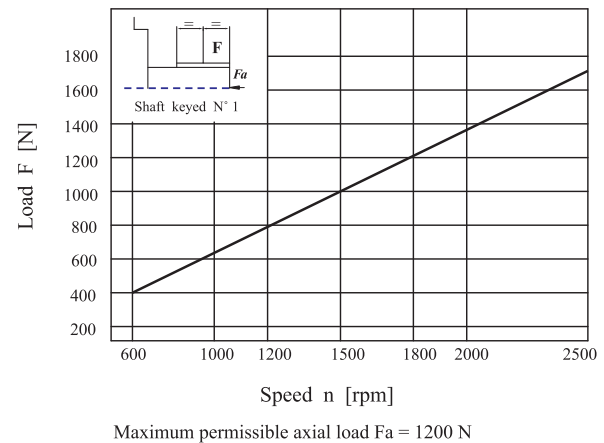



PT6DRSS Ordering Code

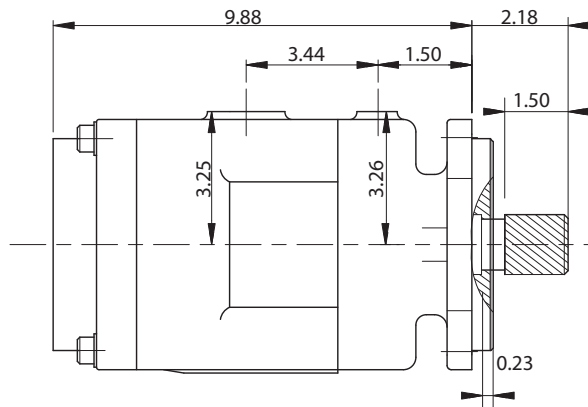
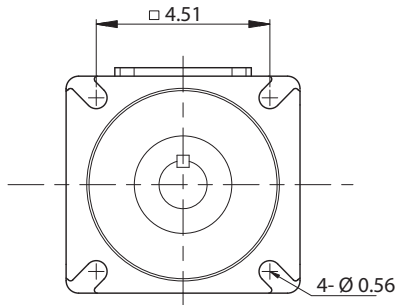

Shaft Code 3
SAE C Splined Shaft
12/24 dp, -14 teeth
30° pressure angle
Flat root side fit

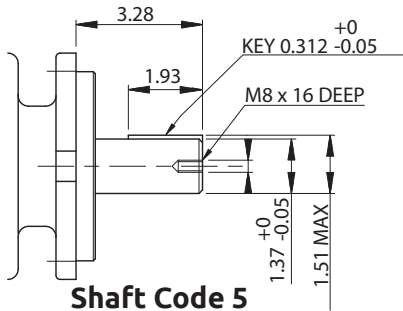

Shaft Code 5
(Keyed no SAE)

Shaft code 2
(Keyed SAE CC)

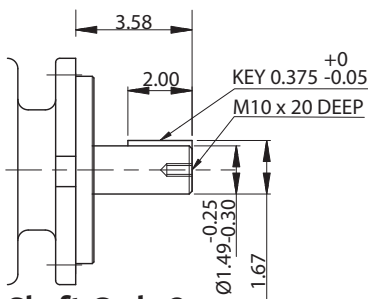

Shaft Code 2
(Keyed SAE CC)

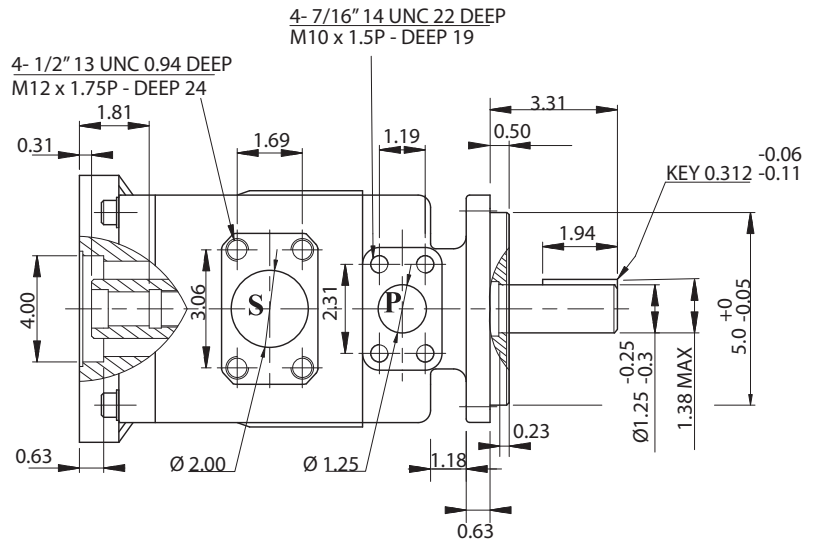

Shaft torque limits in $\frac{3}{4}$ rev x PSI (cm $\frac{3}{4}$ rev x Bar)			
Shaft	V x p max.	Coupling drive	V x p max.
1	38300 (43240)	SAE A	9743 (11000)
2	58491 (66036)	SAE B	18246 (20600)
3	54207 (61200)	SAE BB	28937 (32670)
5	49247 (55600)	SAE C	33118 (37390)
		SAE 11 tooth	14039 (15850)

Adapter	SAE "A"			SAE "B"		SAE "C"
Coupling drive	SAE A	SAE 11 tooth	SAE B	SAE B	SAE BB	SAE C
Number of teeth	9	11	13	13	15	14
Pitch	16/32	16/32	16/32	16/32	16/32	12/24
Pressure angle	30°	30°	30°	30°	30°	30°
Major dia. (min)	15.875	19.05	22.225	22.225	25.400	31.750
Minor dia. (min)	12.700	16.00	19.134	19.134	22.268	27.585

PT6DRSS/PT6DRSSM OPERATING CHARACTERISTICS - TYPICAL 115 SUS (24 cst)

Series	Volumetric Displacement in 3 /rev (cm 3 /rev)	Flow Q in GPM (l/min) @ 1500 RPM			Input Power HP (KW) @ 1500 RPM			P. Max PSI (Bar)	MAX RPM
		p = 0 PSI (0 Bar)	p = 2000 PSI (140 Bar)	p = 3500 PSI (240 Bar)	p = 100 PSI (7 Bar)	p = 2000 PSI (140 Bar)	p = 3500 PSI (240 Bar)		
B/014	2.90 (47.6)	18.86 (71.4)	16.41 (62.1)	14.77 (55.9)	3.08 (2.3)	24.81 (18.5)	41.04 (30.6)	3500 (240)	2500
B/017	3.55 (58.2)	23.06 (87.3)	20.61 (78.0)	18.97 (71.8)	3.35 (2.5)	29.77 (22.2)	49.62 (37.0)		
B/020	4.03 (66.0)	26.15 (99.0)	23.70 (89.7)	22.06 (83.5)	3.75 (2.8)	33.39 (24.9)	55.92 (41.7)		
B/024	4.85 (79.5)	31.52 (119.3)	29.06 (110.0)	27.42 (103.8)	4.02 (3.0)	39.69 (29.6)	66.78 (49.8)		
B/028	5.47 (89.7)	35.53 (134.5)	33.07 (125.2)	31.44 (119.0)	4.29 (3.2)	44.52 (33.2)	74.96 (55.9)		
B/031	6.00 (98.3)	38.94 (147.4)	36.48 (138.1)	34.84 (131.9)	4.43 (3.3)	48.54 (36.2)	81.80 (61.0)		
B/035	6.77 (111.0)	43.98 (166.5)	41.53 (157.2)	39.89 (151.0)	4.69 (3.5)	54.58 (40.7)	92.13 (68.7)		
B/038	7.34 (120.3)	47.66 (180.4)	45.20 (171.1)	43.56 (164.9)	4.96 (3.7)	58.87 (43.9)	99.64 (74.3)		
B/042 (1)	8.30 (136.0)	53.89 (204.0)	51.43 (194.7)	49.80 (188.5)	5.36 (4.0)	66.25 (49.4)	112.24 (83.7)	2200	
B/045 (1)	8.89 (145.7)	57.72 (218.5)	55.26 (209.2)	53.63 (203.0)	5.50 (4.1)	70.81 (52.8)	120.02 (89.5)		
B/050 (1)	9.64 (158.0)	62.61 (237.0)	60.15 (227.7)	59.17 (224.0) (2)	5.90 (4.4)	76.44 (57.0)	113.99 (85.0) (2)		

(1) B/042 - B/045 - B/050 = 2200 RPM max

(2) B/050 = 3062 PSI max. int.

Min Speed: 600 RPM

EXAMPLE

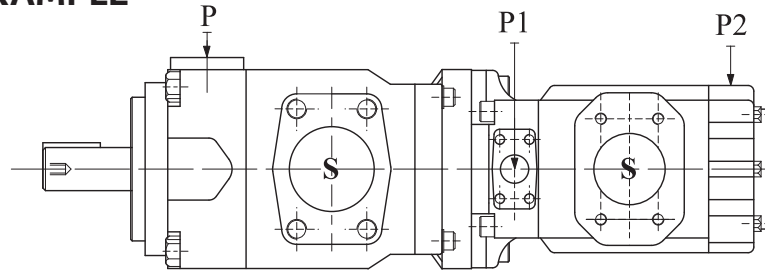

PT6ER + PT6CC

- 1. Define front pump
PT6ER-***-1 R 02-B21-A1
- 2. Define rear pump
PT6CC-***-***-5 R 01-C 100
- 3. Define mounting
Assy tandem VV03

Rear pump		Drive train pump			
		PT6*R (single pumps)		PT6***R (single pumps)	
Series	Shaft	Coupling	Adapter	Coupling	Adapter
PT6C* PT6CR* PT6CSH*	3 4	2 3	B B	Not available	
PT6CC*	3 5	3 2	B B	Not available	
PT6D* PT6DR* PT6DC* PT6DCC*	3	4	C	Not available	
PT6E* PT6ER* PT6EC* PT6ED*	3	4	C	Not available	
PTE	4 3	1 5	A A	Available	
PT7B	3 4	2 3	B B	Not available	



PORTING DIAGRAMS-PT6 SERIES INDUSTRIAL APPLICATION

PT6DD- PT6DDS- PT6EE PT6EES- PT6ED

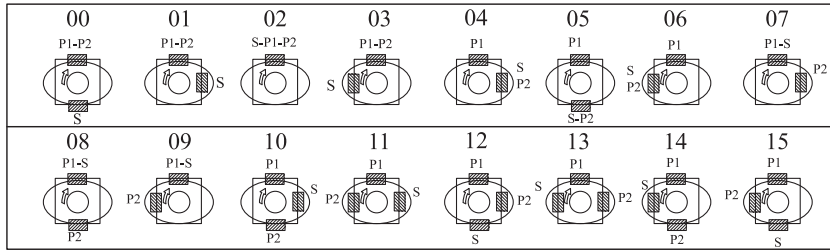

PT6CC- PT6DC- PT6EC PT6GCC- PT67CB PT67DB- PT67EB PT6QDC

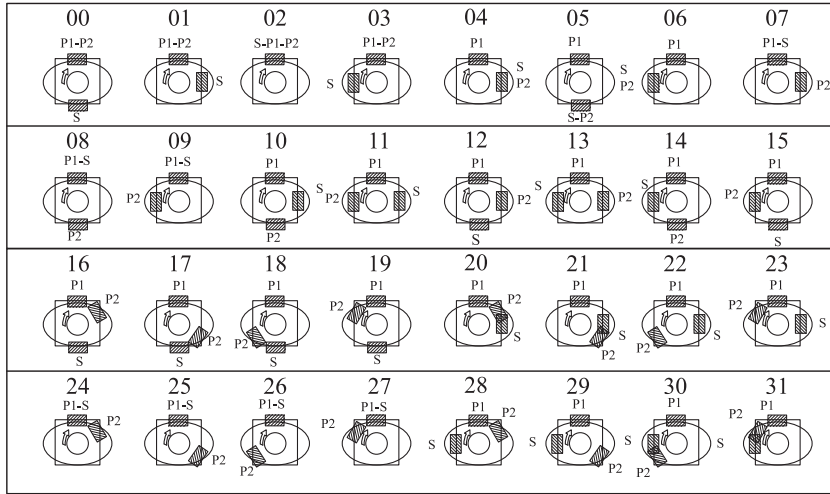

PT6DCC- PT6EDC PT6DCCS- PT67DCB

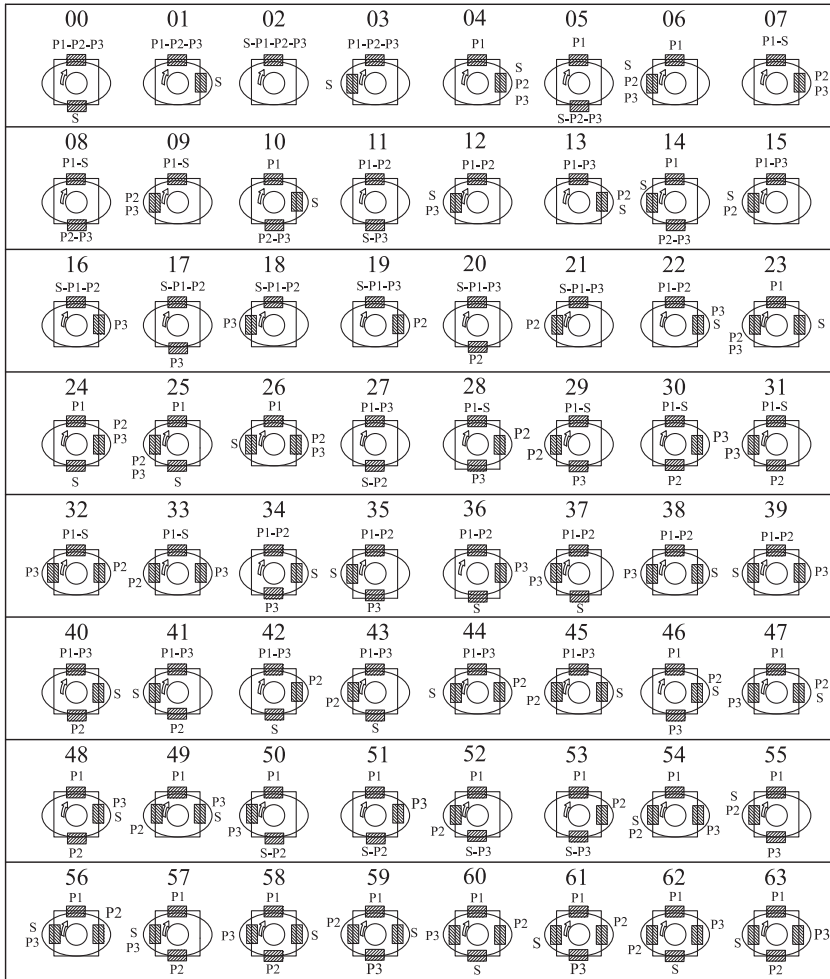

**PT6DCC- PT6EDC-
PT6DCCS- PT67DCB**

P1



S	P2	P3				P2	P3			
		02	16	17	18		20	30	08	31
		19	07	28	32		21	33	29	09
		01	22	34	38		40	48	10	58
		13	04	46	47		45	49	59	23
		00	36	11	37		27	51	05	50
		42	24	53	60		43	62	52	25
		03	39	35	12		41	63	14	57
		44	26	61	56		15	54	55	06



HIGH PERFORMANCE VANE MOTOR PM*

ALTERNATE FLUIDS

PM* series high speed, high pressure fixed displacement Vane Motors offer a wide choice of torque ratings, reversible shaft rotation, foot or flange mounting and choice of port locations.

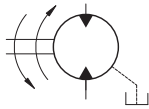

Single Motor

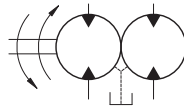

Double Motor

HYDRAULICALLY BALANCED DESIGN

Vane Motors are hydraulically balanced to reduce wear and heat producing friction. The vane, rotor and cam ring are pressure balanced to increase life and efficiency over full speed range.

REPLACEABLE ROTARY KITS

The rotary kit assembly is easily replaceable. The torque capability of motors within the same series can be changed by changing the rotary kit or cam ring.

ROTATION

Motors may be stalled or reversed repeatedly under load without damage.

SPEED RANGE

Starting to maximum speed (4000 RPM) with full torque capability during acceleration. These motors can start smoothly at full load. To fully realize the smooth start characteristic, the designed maximum operating speed for single cartridge motors should be above 1200 RPM.

For optimum operating efficiency and life, minimum continuous operating speeds should be above 400 RPM, at differential pressure higher than 2000 PSI (140 Bar).

MOUNTING FLEXIBILITY

Ports and mounting conform to ISO-3019-1 standards, thus providing the optimum mounting for connecting pipe work.

LOW TORQUE RIPPLE AT LOW SPEED

While operating at very low speed Vane Motors exhibit very low torque ripple.

HIGH EFFICIENCY

Vane Motors have high volumetric efficiency that is maintained throughout their operating life. The high starting torque efficiency of Vane Motors allow start under high load without pressure overshoots, jerks and high instantaneous horsepower loads. Efficiency varies with motor size, pressure, speed and fluid viscosity and temperature.

SEVERE DUTY VANE MOTORS

Vane Motors have been specially designed to suit severe duty application for pressure up to 3400 PSI, high speeds up to 4000 RPM and fluid lubricity. These are designated as PM4S series and recommended when both, pressure is over 2000 PSI and speed is over 2000 RPM. They are also recommended for fluid viscosity below 25 cSt and speed over 2000 RPM. PM4S motors have longer life at high efficiency.

FIRE RESISTANT FLUIDS

Easily used in the standard PM4S version of Vane Motors. These include phosphate or organic ester fluids and blends water glycol solutions and water oil invert emulsions.

RELIABILITY

These high performance motors have been field proven on a wide variety of applications.

APPLICATIONS

These motors can be widely used in load hoist winch drives, swing drives, propulsion drives, traction drives, etc.

INTERNALLY DRAINED MOTORS (PM4C1, PM4D1, PM4E1)

These motors may be alternately pressurized at port A & B to 2500 PSI (175 Bar) max. Whichever port is at low pressure must not be subjected to more than 50 PSI (3.5 Bar) peak pressure 100 PSI (7 Bar)

EXTERNALLY DRAINED MOTORS

Single Cartridge Motors may be alternately pressurized at ports A & B to 2500 PSI (175 Bar) max. Which ever port is at low pressure should not be subject to more than 500 PSI (35 Bar).

PRESSURE, DRAIN PORT d, 3.5 bar max.

To ensure maximum motor performance in conjunction with your specific application, consult your Permco representative if your application requires:

- minimum speed of less than 100 rpm
- Overrunning loads
- Indirect drive
- Braking or retarding

Permco offers vane motors with option of keyed or splined shafts. Keyed shafts are supplied with high strength heat treated keys. If the key is replaced, it must be heat treated between 27 and 34 RC hardness. The corners of the keys must be chamfered 0.03" to 0.04" at 45° to clear radii in the key way. Alignment of keyed shaft must be within tolerances given for splined shaft.



HIGH PERFORMANCE VANE MOTOR PM*

SHAFTS, COUPLINGS AND FEMALE SPLINES

- The shaft will accept a maximum misalignment of .002" TIR when the pump is foot mounted and .001" when flange mounted. The angular alignment of two spline axes must be less than 0.1° (0.002 per 1").
- The coupling spline must be lubricated with lithium moly-disulfide grease or a similar lubricant.
- The coupling must be hardened to a hardness between 27 and 45 RC.
- The female spline must be made to conform to the Class 1 fit as described in SAE-J498B (1971). This is described as a Flat Root Side Fit.

Series	Speed rpm									
	500		1000		2000		3000		3600	
	psi	bar	psi	bar	psi	bar	psi	bar	psi	bar
PM4C/ PM4SC	10	0.7	20	1.4	45	3.1	80	5.5	135	9.3
PM4D/ PM4SD	10	0.7	20	1.4	45	3.1	80	5.5	135	9.3
PM4E/ PM4SE	20	1.4	40	2.8	75	5.2	160	11		

RECOMMENDED FLUIDS

PETROLEUM BASED ANTIWEAR R & O FLUIDS

These fluids are recommended fluid for PM4 series Vane Motors. Maximum catalog ratings and performance data are based on operation with these fluids.

SHAFT LOADS

Axial or radial load are permissible. Both loads should not be applied simultaneously.

ALTERNATE FLUIDS

The use of fluids other than petroleum based antiwear R & O fluids requires that the maximum ratings of the motors be reduced. In some cases the minimum replenishment pressures must be increased. Contact your Permco representative for more details.

OPERATING TEMPERATURES AND VISCOSITIES

Operating temperatures are a function of fluid viscosities, fluid type and the motors. Fluid viscosity should be selected to provide optimum viscosity at nominal operating temperatures. For cold starts, the motors should be operated at low speed and pressure until fluid warms up to an acceptable viscosity for full power operation.

VISCOSITY

Max (cold start, low speed & pressure)	862mm ² /s (cSt)
Max (full speed & pressure)	108mm ² /s (cSt)
Optimum (max. life)	30mm ² /s (cSt)
Min (full speed & pressure)	10mm ² /s (cSt)

VISCOSITY INDEX

90 min. Higher values extend range of operating temperatures, and life time.
Fluid temperature (0°)F max. 353(+80°C) min. 255(-18°C)

FLUID CLEANLINESS

The fluid must be cleaned before and during operation to maintain contamination level of NAS 1638 class 8 (or ISO 18/4) or better. 245 micron normal filters may be adequate but do not guarantee the required cleanliness levels.

REPLENISHMENT PRESSURE

The inlet port of the motor must be supplied with minimum replenishment pressure (see chart) to prevent cavitation during dynamic braking.



HIGH PERFORMANCE VANE MOTOR PM*

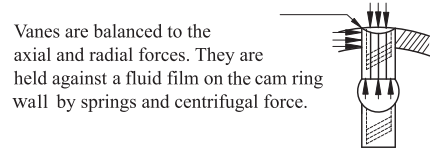
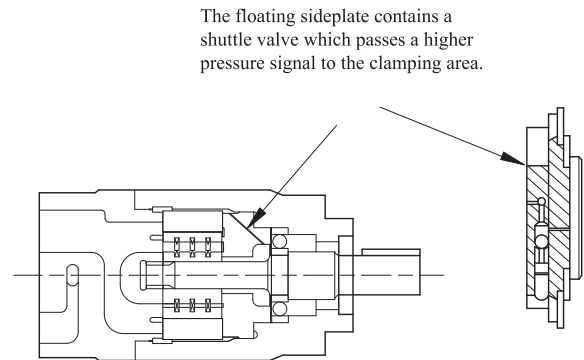
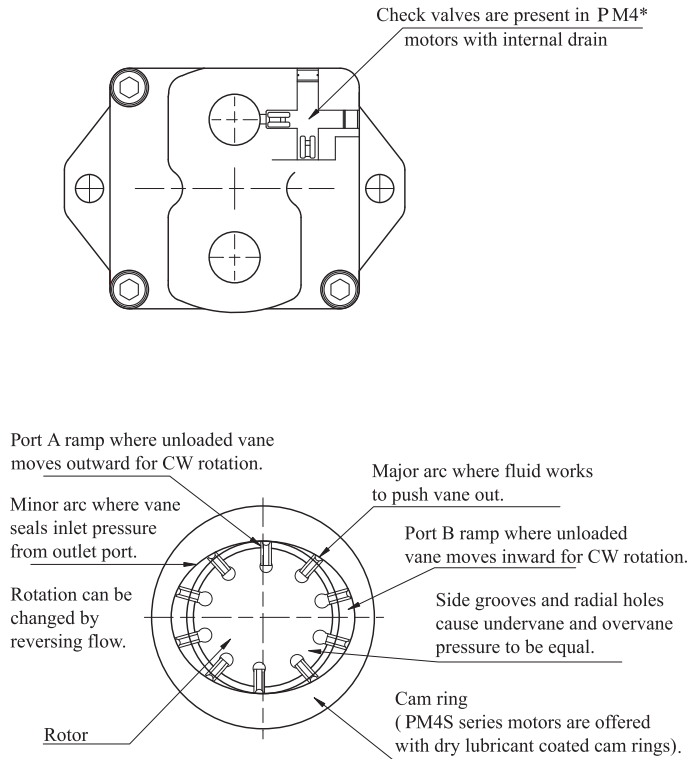

Vaness are fitted in the slotted rotor slide radially and follow the elliptical contour of the cam ring and seal against it. The cam ring has two major and two minor radial sections joined by transitional sections called ramps. These contours and the pressures exposed to them are balanced diametrically.

Direction of shaft rotation is governed by the direction of fluid flow through the port connections located in the body cover. These motors are reversible by reversing flow to and from the ports.

Light springs urge the vaness radially against the cam contour assuring a seal at zero speed so the motor can develop starting torque. The springs are assisted by centrifugal force at higher speeds. Radial grooves and holes through the vaness equalize radial hydraulic forces on the vaness at all times. Fluid enters and leaves the motor cartridge through openings in the side plates at the ramps. Each motor port connects to two diametrically opposed ramps. Pressurized fluid entering at port A torques the rotor clockwise. The rotor transports it to the ramp openings which connect to port B from which it returns to the low pressure side of the system. Pressure at port B torques the rotor counterclockwise. The fluid film separates the rotor axially from the side port plate surfaces. The front side plate, clamped against the cam ring by this pressure, maintains optimum clearance to accommodate dimensional changes due to temperature and pressure. A 3-way shuttle valve in the side plate causes clamping pressure to equal the pressure in port A or B, whichever is higher.

DESCRIPTION

Vane Motors have positive displacement, hydraulically balanced cartridge units, with drive speed dependent on the motor size and gpm delivery to the inlet port. The units are capable of operating at high speeds and high pressures, or higher speeds at lower pressures. These motors may be operated in either direction or rotation, reversed or stalled under load conditions without damage.

PRINCIPLE OF OPERATION

The operating principle of a Single Vane Motor is illustrated in the figure above. Rotation of the motor shaft is caused by differential pressure across the motor exerting a force against the vaness. This force is in effect tangential to the rotor and causes the rotor to turn, carrying the motor shaft with it.

	Mounting Standard (SAE J477c ISO/3019-1)	Weight		Option for inlet & outlet port SAE 4 bolt SAE threaded J781c ISO/DIS 6162-1	Moment of Inertia	
		lbs	Kgs		lbs.in ²	Kg m ² x 10 ⁻⁴
PM4C-PM4C1 PM4SC-PM4SC1	SAE - B	34	15	1"	2.7	7.9
PM4D-PM4D1 PM4SD-PM4SD1	SAE - C	60	27	1 1/4"	1.4	4.11
PM4E-PM4E1 PM4SE-PM4SE1	SAE - C	99	45	2"	20.0	58.7



PERFORMANCE CURVES OIL VISCOSITY 24 CST (45° C)

PM4C-024

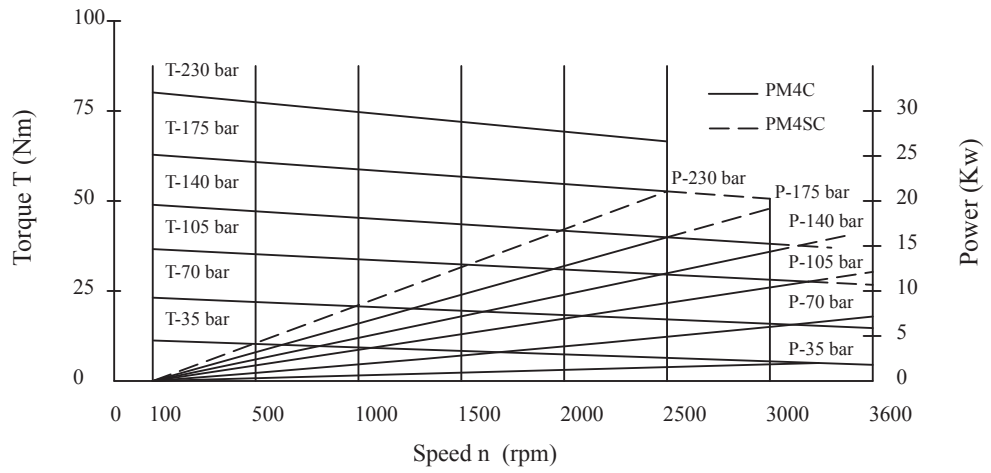

PM4C-027

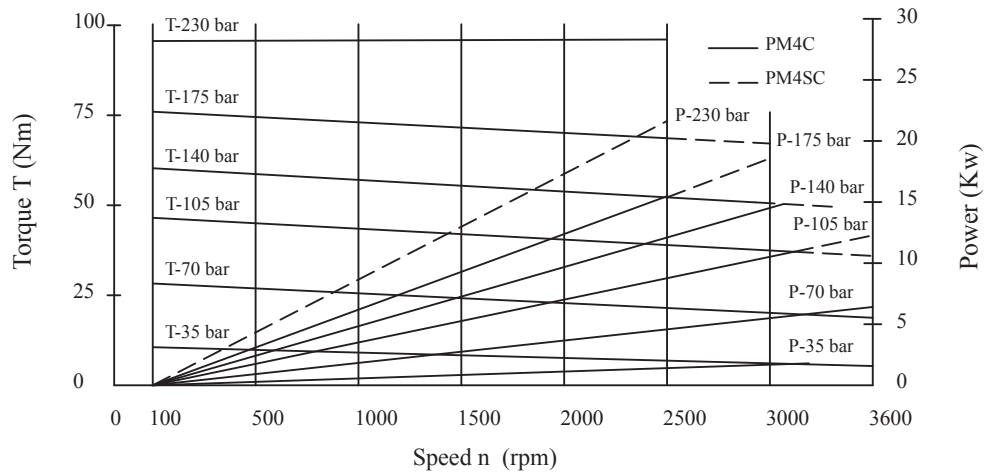

PM4C-031

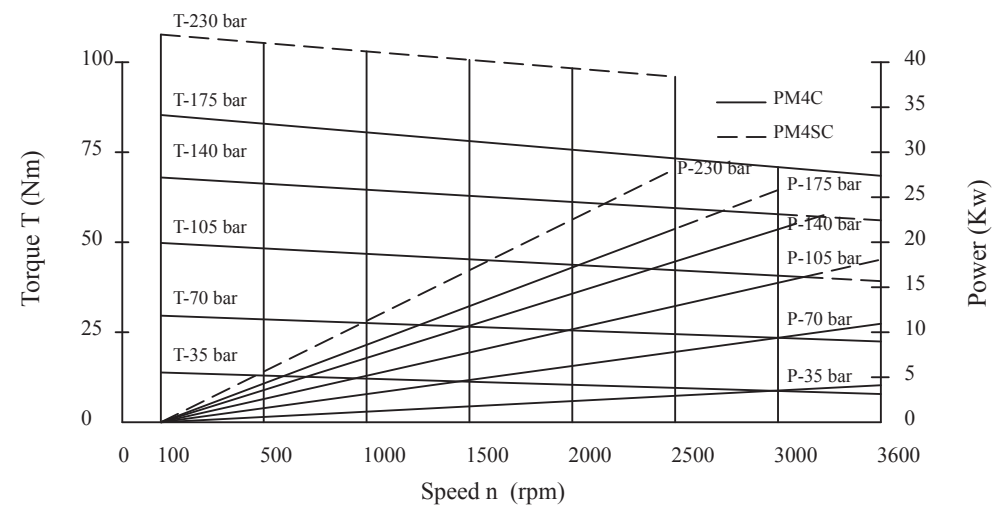



PERFORMANCE CURVES OIL VISCOSITY 24 CST (45° C)

PM4C-043

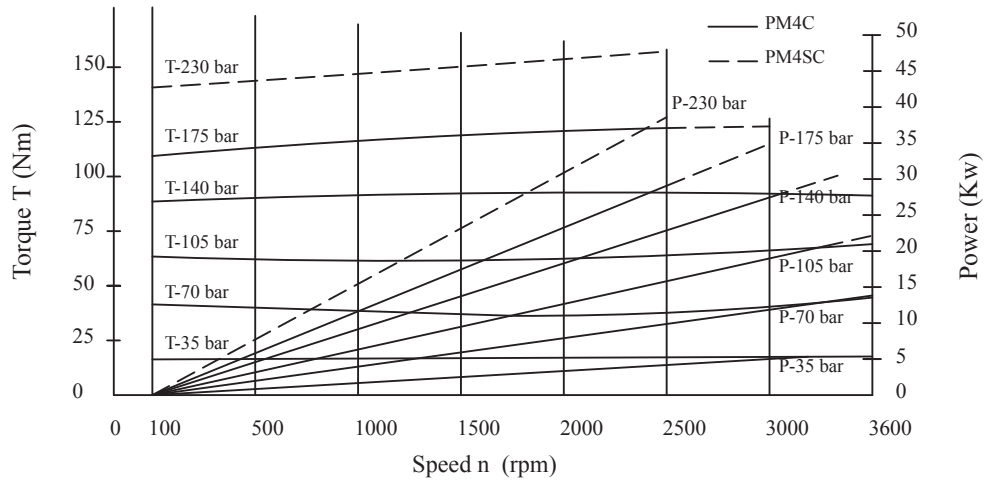

PM4C-055

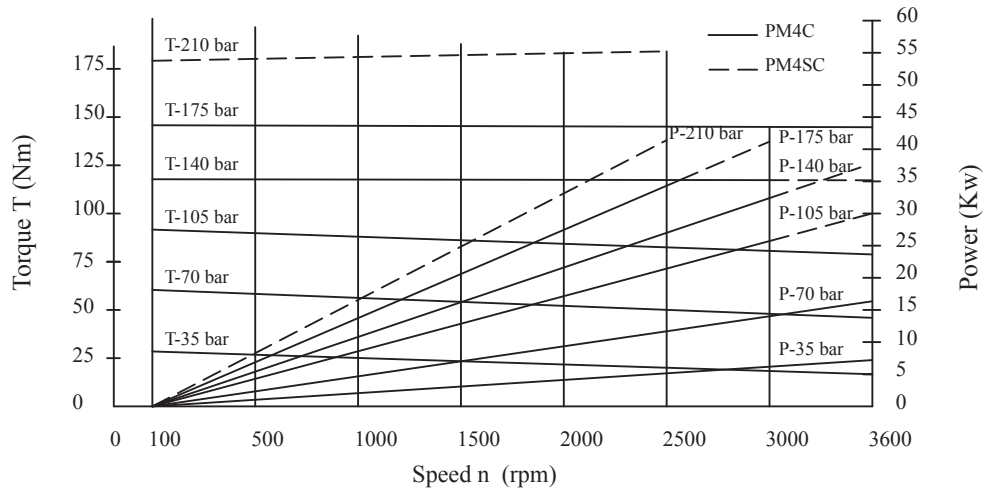

PM4C-067

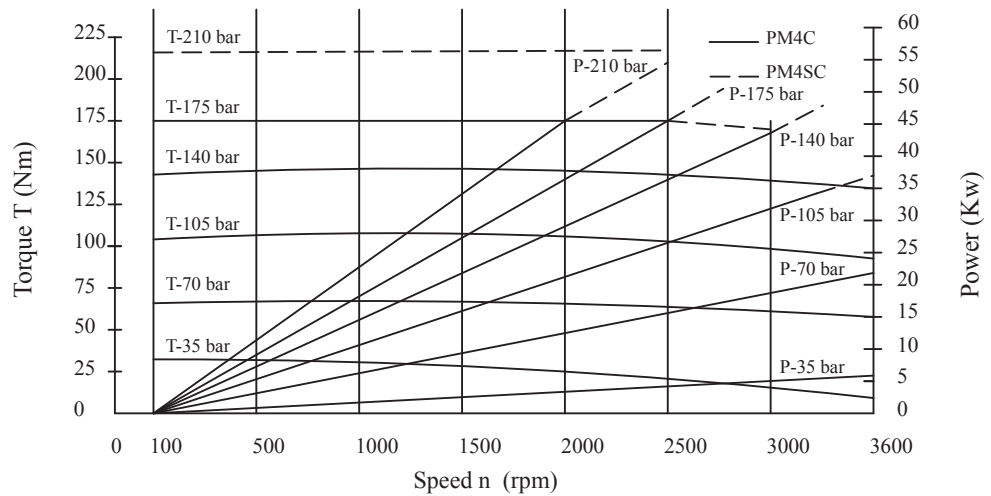



PERFORMANCE CURVES OIL VISCOSITY 24 CST (45° C)

PM4C-075

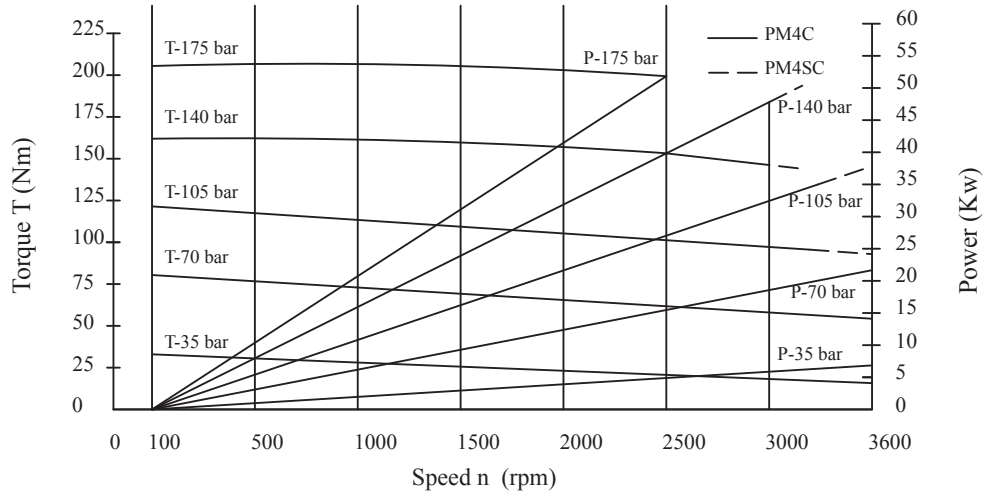



PERFORMANCE CURVES OIL VISCOSITY 24 CST (45° C)

PM4D-062

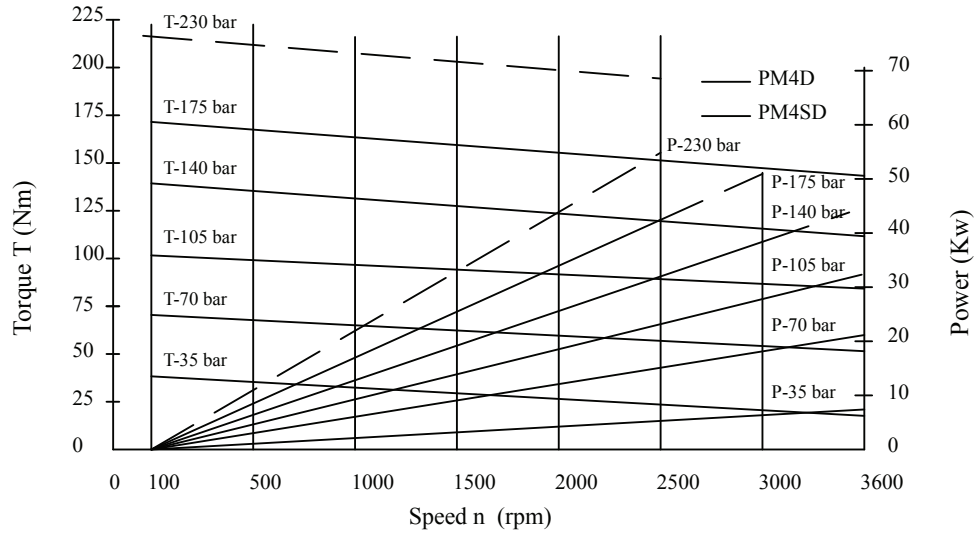

PM4D-074

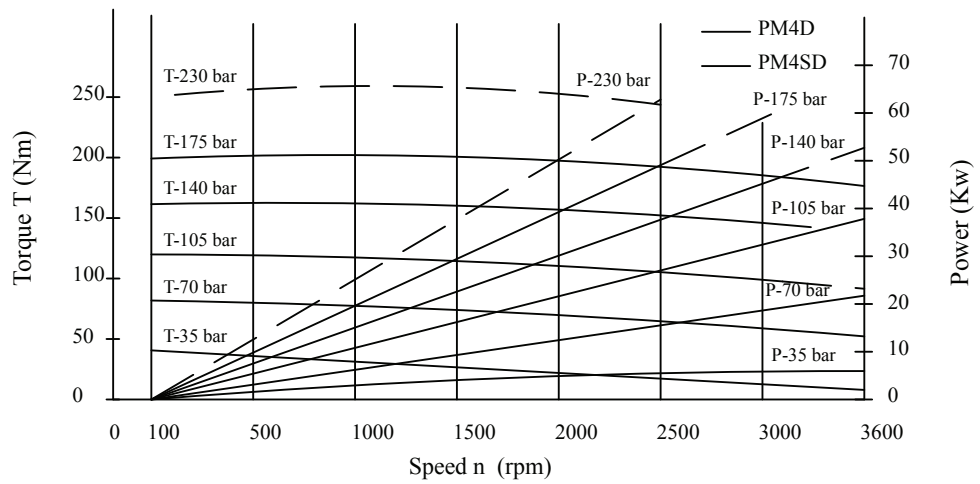

PM4D-088

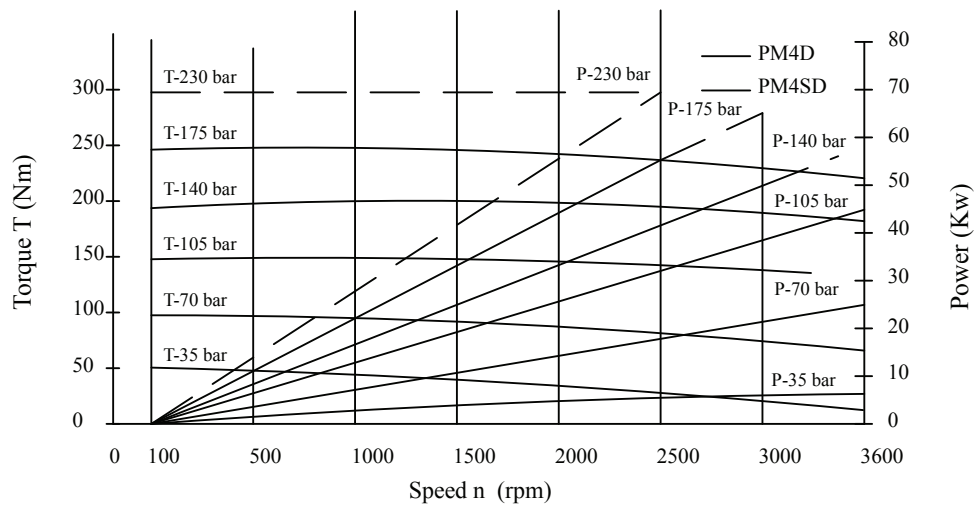



PERFORMANCE CURVES OIL VISCOSITY 24 CST (45° C)

PM4D-102

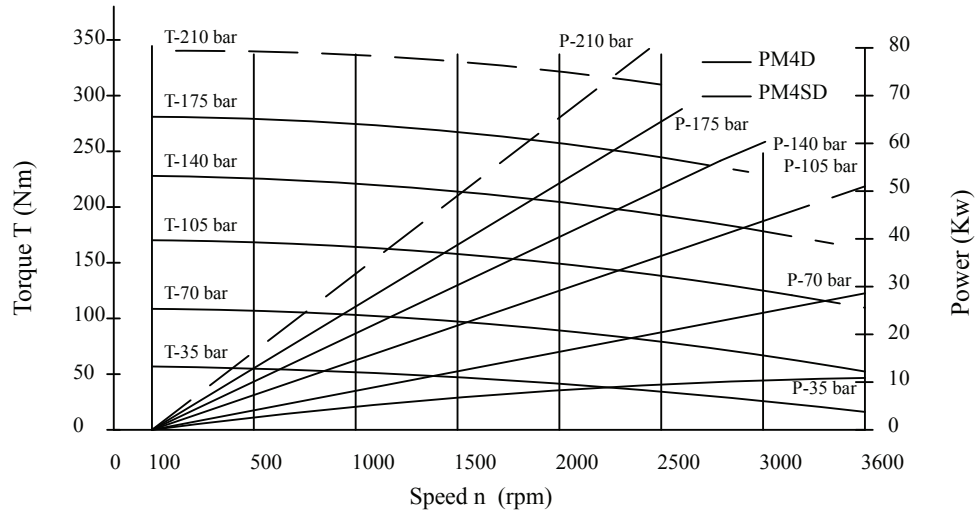

PM4D-113

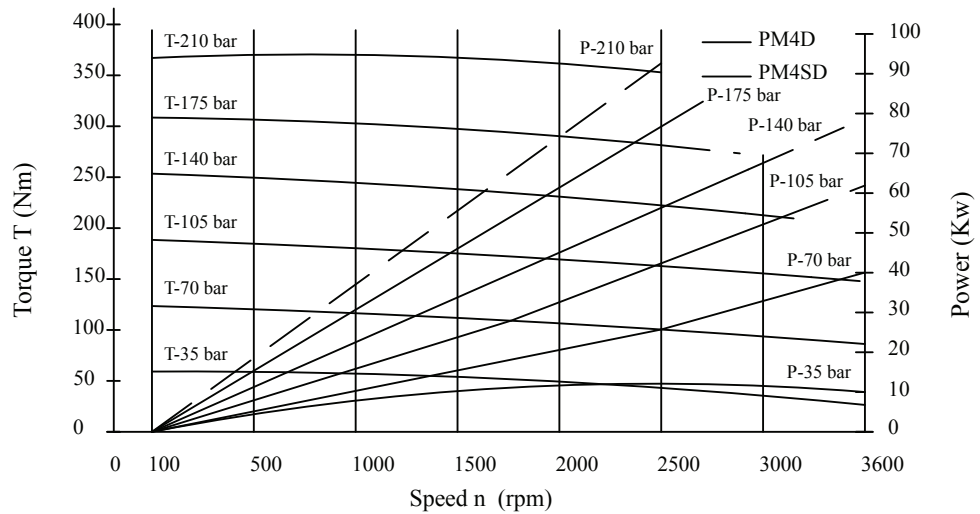

PM4D-128

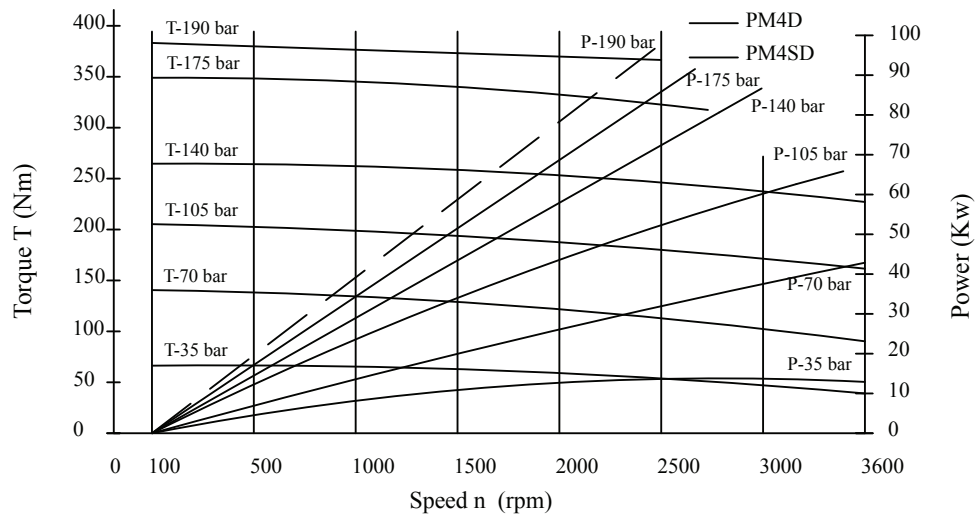



PERFORMANCE CURVES OIL VISCOSITY 24 CST (45° C)

PM4D-138

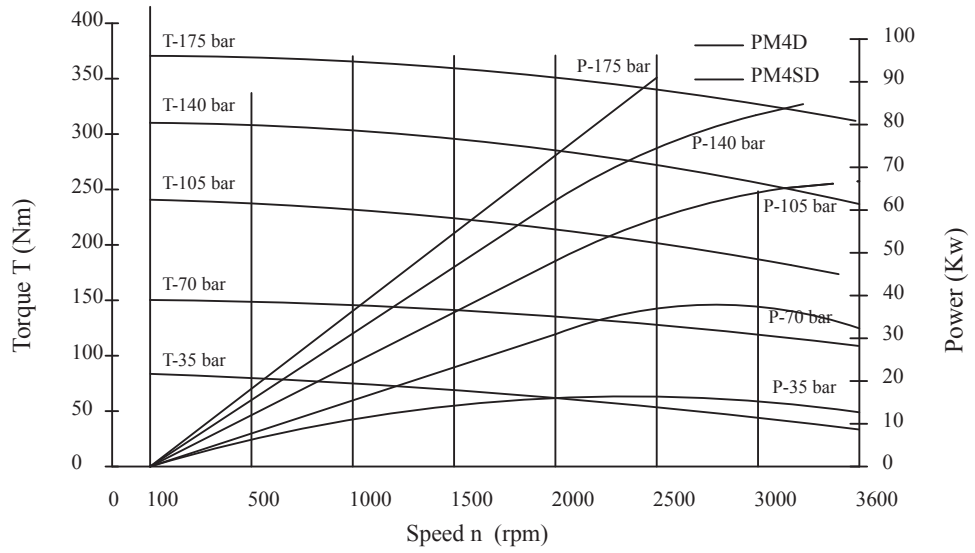



PERFORMANCE CURVES OIL VISCOSITY 24 CST (45° C)

PM4E-153

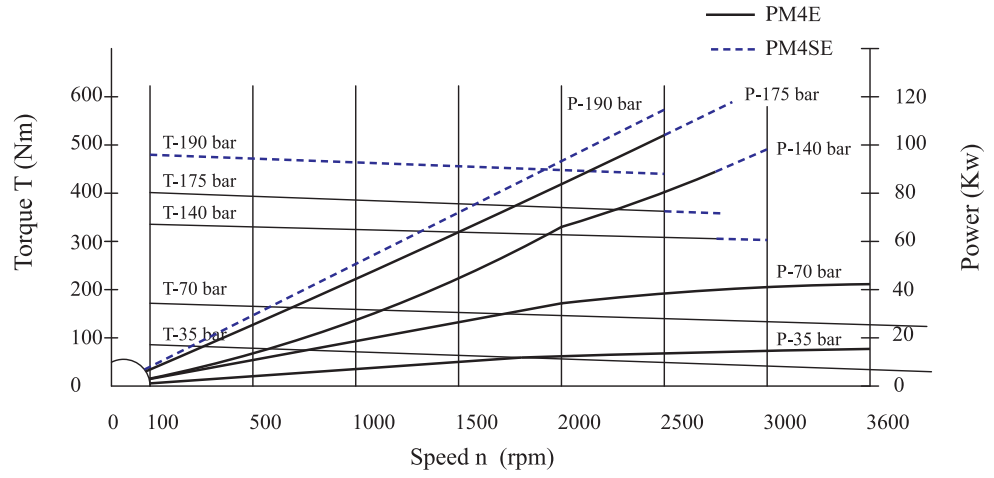

PM4E-185

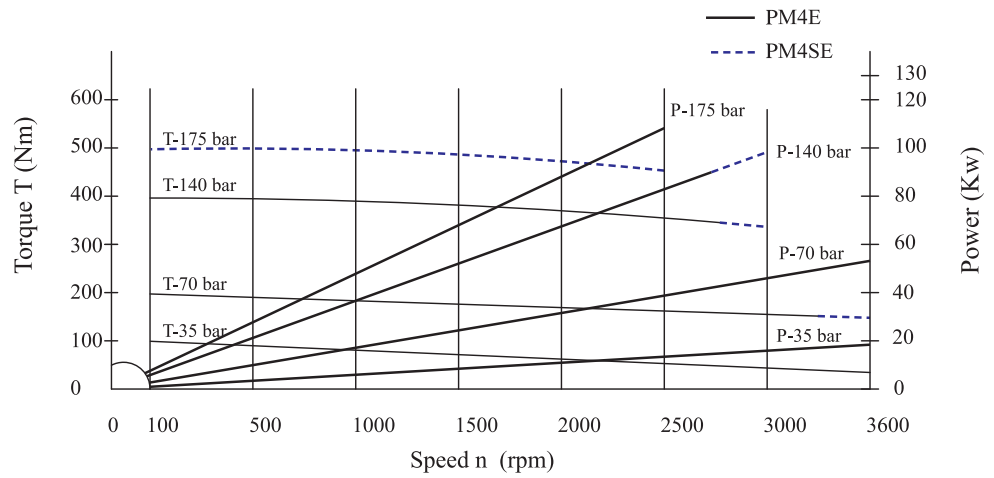

PM4E-214

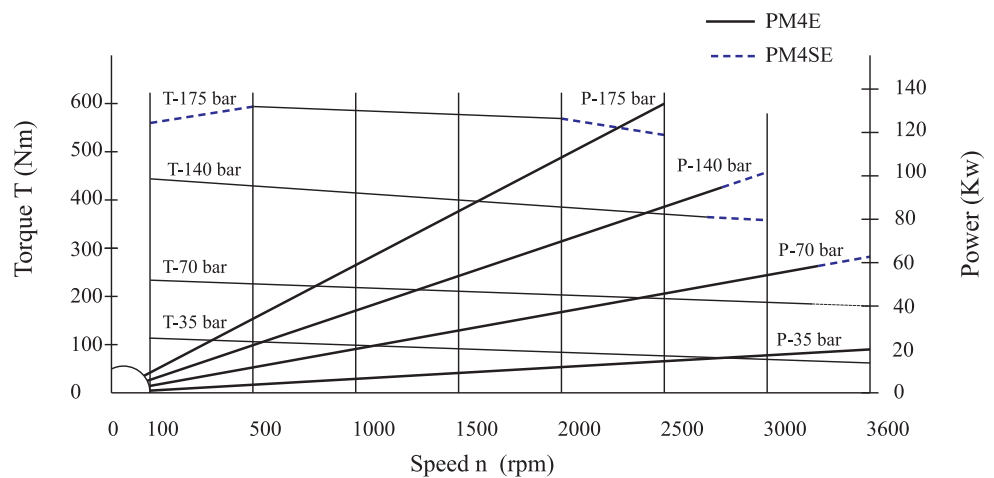



INTERNAL LEAKAGE AND PERMISSIBLE RADIAL AND AXIAL LOADS OIL VISCOSITY 24 cSt (45° C)

PM4C/PM4SC

INTERNAL LEAKAGE

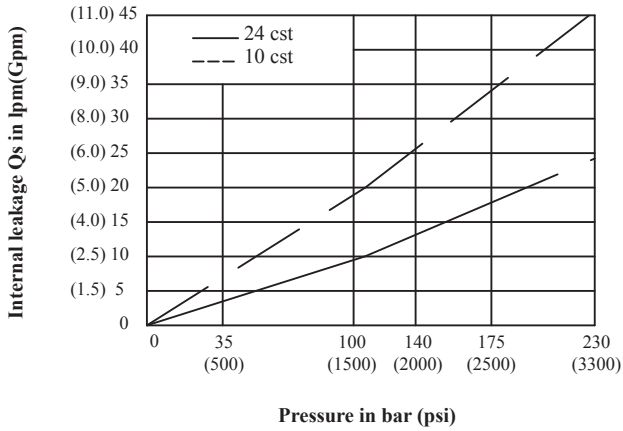

PERMISSIBLE RADIAL AND AXIAL LOADS

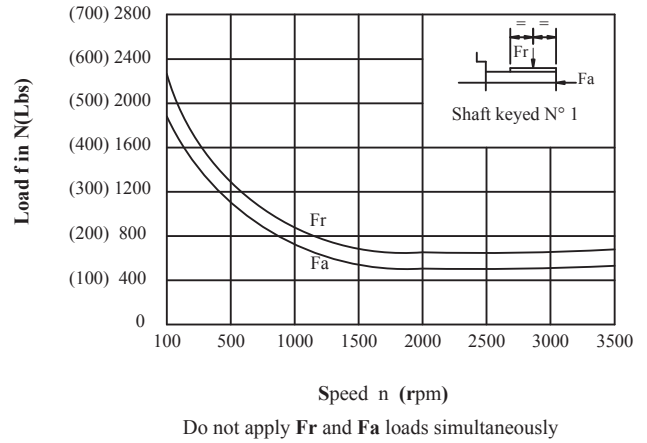

PM4D/PM4SD

INTERNAL LEAKAGE

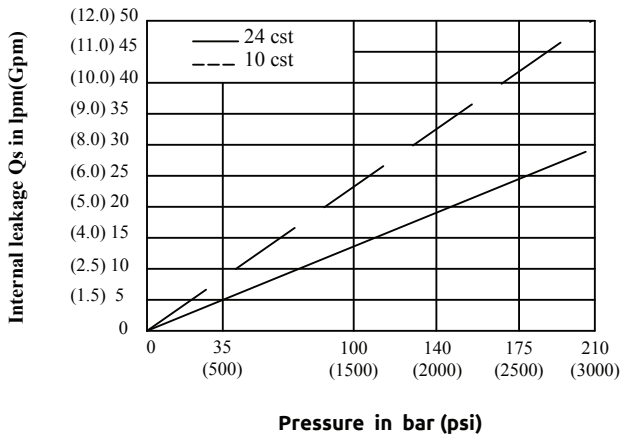

PERMISSIBLE RADIAL AND AXIAL LOADS

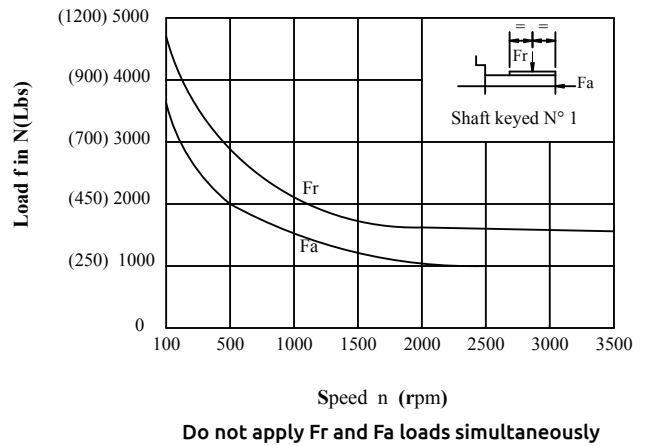

PM4E/PM4SE

INTERNAL LEAKAGE

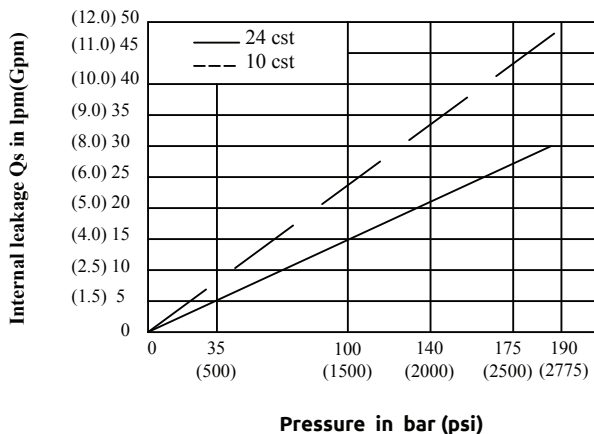

PERMISSIBLE RADIAL AND AXIAL LOADS

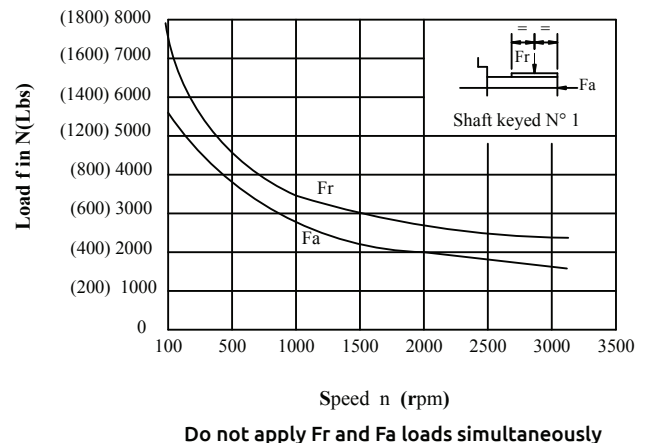

Fr = Radial Force

Fa = Axial Force



MAXIMUM SPEED PRESSURE RATINGS PM4* SERIES

Series	Size	Displ	Maximum Pressure					Operating pressure range drain	Max. speed for low loaded condition 1	Max. speed for max. pressure ratings					
			HF-0 HF-2	HF-2A	HF-1	HF-3 HF-5	HF-4			HF-0, HF-2		HF-2A		HF-1	
			PSI	PSI	PSI	PSI	PSI			Cont.	Int. 2)	Cont.	Int. 2)	Cont.	Int. 2)
PM4	C C1	024	2538	2538	2538			50	4000	2500	3600	2500	3000	2000	2500
		027													
		031													
		043													
		055													
		067													
	075														
	SC SC1	024	3335	3335	2538	2538	2030								
		027													
		031													
		043	3062	3062											
		055													
		067	2538	2538											
	075														
	D D1	062	2538	2538	2030										
		074													
		088													
		102													
		113													
		128													
	138														
	SD SD	062	3335	2755	2030	2030	2030								
		074													
		088													
		102	3062	2755											
		113													
		128	2755	2755											
	138	2538			2538										
153	2538		2538	2030											
185															
214															
SE SE1	153	2755		2030	2030	2030									
	185						2610								
	214							2538							

1) Low loaded condition 507 PSI for PM4, 1160 PSI max. for PM4S

2) Intermittent speed - Do not exceed 6 seconds per minute of operation.

HF-0, HF-2 = Antiwear petroleum base. HF-2A = Crankcase. HF-1 = Non antiwear petroleum base. HF-5 = Synthetic fluids.

HF-3 = Water in oil emulsion. HF-4 = Water glycols.

Internal drain: All motors can be equipped with internal drains. the model numbers will be PM4C1, PM4SC1, PM4D1, PM4SD1, PM4E1, PM4SE1.



Motor Selection PM4*

MOTOR CALCULATIONS

Required performance:
 Torque: T(Nm) 140
 Pump flow available
 at 24 cSt: Qp(l/min) 115
 Speed: n(RPM) 1500
 Pressure p(Bar) 175

1. Check that available power is compatible with required power (0.85 estimated overall efficiency)

FORMULA AND EXAMPLE

Vi = Volumetric displacement (cm³/rev)
 Qm = Actual flow used by motor (l/min)
 Qs = Pump internal leakage (l/min)
 Qp = Pump available flow (l/min)

Two ways to calculate:

2a. Calculate Vi from T required torque

$$V_i = \frac{20 \pi \times T}{p} = \frac{20 \pi \times 140}{163} = 50.26 \text{ cm}^3/\text{rev}$$

2b. Calculate Vi from Qp available motor flow

3a. Choose motor from Vi immediately greater than Vi calculated
 PM4C-055 Vi = 58.8 cm³/rev (see page 91)

3b. Choose motor from Vi immediately less than Vi calculated
 PM4C-067 Vi = 71.1 cm³/rev (see page 91)

4a. Check motor pressure for T = 140Nm around 1500 RPM
PM4C-055
 T = 140 Nm
 n = 1500 RPM
 p = 163 Bar (see page 82)

4b. Check motor pressure with T = 140Nm at 1500 RPM
PM4C-067
 T = 140 Nm
 n = 1500 RPM
 p = 163 Bar (see page 82)

5a. Flow loss **PM4C-055** at 163 Bar at 24 cSt
 Qs = 16 l/min (see page 88)
 Real flow used by the motor:
 Qm = Qp - Qs = 115 - 16 = 99 l/min

5b. Flow loss **PM4C-067** at 140 Bar at 24 cSt
 Qs = 14 l/min (see page 88)
 Real flow used by the motor:
 Qm = Qp - Qs = 115 - 14 = 101 l/min

6a. Real speed of motor:

$$n = \frac{Q_m \times 1000}{V_i} = \frac{99 \times 1000}{58.8} = 1684 \text{ RPM}$$

6b. Real speed of motor:

$$n = \frac{Q_m \times 1000}{V_i} = \frac{101 \times 1000}{71.1} = 1420 \text{ RPM}$$

Real Performances:
 Vi = 58.8 cm / rev
 n = 1684 RPM
 T = 140 Nm
 p = 163 Bar } **PM4C-055**

Real Performances:
 Vi = 71.1 cm / rev
 n = 1420 RPM
 T = 140 Nm
 p = 140 Bar } **PM4C-067**

In each case always choose the smallest motor which will operate at the highest speed and pressure, and offers the most efficient solution.

Throughout this catalog you will find dimensions, flows, power, pressures and loads in metric terms, to convert please use the following conversion guide.

To convert mm to inches divide by 25.4
 To convert liters into gallons multiply by .2642
 To convert bar to psi multiply by 14.5

10 cSt = 60 SUS and 24 cSt = 115 SUS

To convert KW to HP multiply by 1.341
 To convert newtons to pounds force multiply by .2248
 To convert cm /rèv to in /rèv divide by 16.387

PM4*C1 \ **PM4*C** - **024- 1 N 00** - **A 1** **02 ***
 ① ② ③ ④ ⑤ ⑥ ⑦ ⑧ ⑨ ⑩

① **Series internal drain**

② **Series external drain**
PM4*C1/PM4*C - SAE-B 2-Bolt Mount

③ **Torque**
 024 = 0.24 in.lb/PSI (0.39 Nm/bar)
 027 = 0.28 in.lb/PSI (0.45 Nm/bar)
 031 = 0.33 in.lb/PSI (0.55 Nm/bar)
 043 = 0.45 in.lb/PSI (0.74 Nm/bar)
 055 = 0.57 in.lb/PSI (0.93 Nm/bar)
 067 = 0.69 in.lb/PSI (1.13 Nm/bar)
 075 = 0.78 in.lb/PSI (1.27 Nm/bar)

④ **Type of Shaft**
 1 = Keyed (SAE B)
 2 = Keyed (No SAE)
 3 = Splined (SAE B)

⑤ **Rotation**
 N = Bi-directional

*S = Severe duty motor
(Heavy Duty Rotor & Cam Ring)

⑥ **Porting Combination**
00 = standard

⑦ **Design Letter**

⑧ **Seal Class**
1=HNBR

⑨ **Port Connections**
 01 = SAE threaded port
 SAE drain
 02= SAE 4 bolt flange
 UNC threaded- SAE drain
 04= SAE 4 bolt flange
 UNC threaded- BSPP drain
 M4= SAE 4 bolt flange
 Metric threaded- BSPP drain

⑩ **Modifications**

View from shaft end

CW rotation A=inlet B=outlet
 CCW rotation A=outlet B=inlet

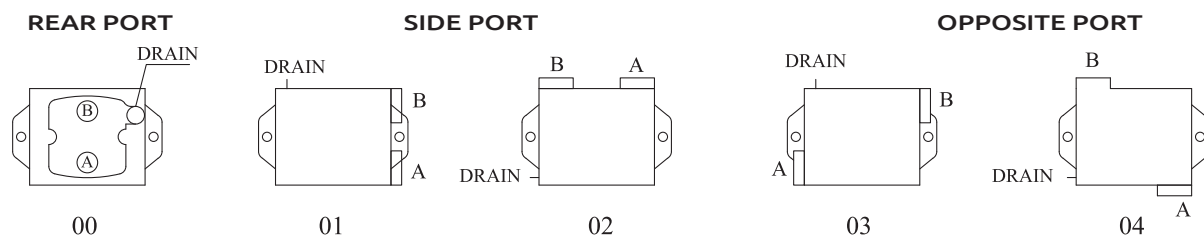

Porting Combination

OPERATING CHARACTERISTICS - TYPICAL 115 SUS (24 cSt)

Model	Series	Volumetric Displacement		Input flow at n = 2000 RPM			Torque T at n = 2000 RPM		Power output at n = 2000 RPM		
		in ³ /rev	cm ³ /rev	Theoretical GPM	(lpm)	2500 PSI (175 Bar) Δ p GPM	(lpm)	2500 PSI (175 Bar) Δ p in.lbs	(Nm)	2500 PSI (175 Bar) Δ p HP	(KW)
PM4C	024	1.49	(24.4)	12.94	(49.0)	17.70	(67.0)	535.40	(60.5)	17.03	(12.7)
	027	1.72	(28.2)	14.79	(56.0)	19.55	(74.0)	619.47	(70.0)	19.71	(14.7)
	031	2.11	(34.5)	18.23	(69.0)	22.98	(87.0)	768.14	(86.8)	24.14	(18.0)
	043	2.84	(46.5)	24.57	(93.0)	29.32	(111.0)	1061.95	(120.0)	33.66	(25.1)
PM4SC	055	3.59	(58.8)	31.17	(118.0)	35.93	(136.0)	1318.59	(149.0)	41.84	(31.2)
	067	4.34	(71.1)	37.51	(142.0)	42.27	(160.0)	1504.43	(170.0)	47.74	(35.6)
	075	4.89	(80.1)	42.27	(160.0)	47.02	(178.0)	1752.22	(198.0)	55.65	(41.5)



PM4C DIMENSIONAL DRAWING

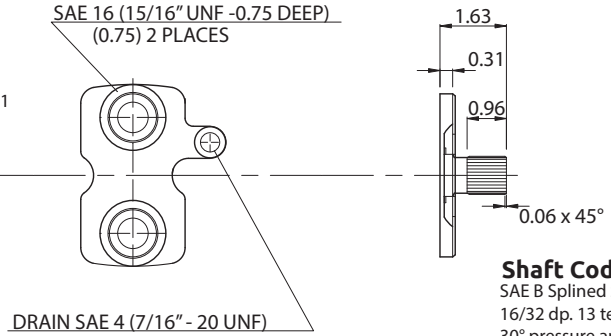
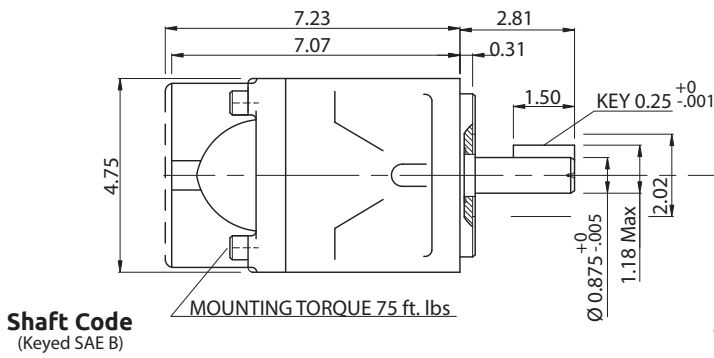

Shaft Code 3
SAE B Splined Shaft
16/32 dp, 13 teeth
30° pressure angle
Flat root side fit

SAE THREADED PORT

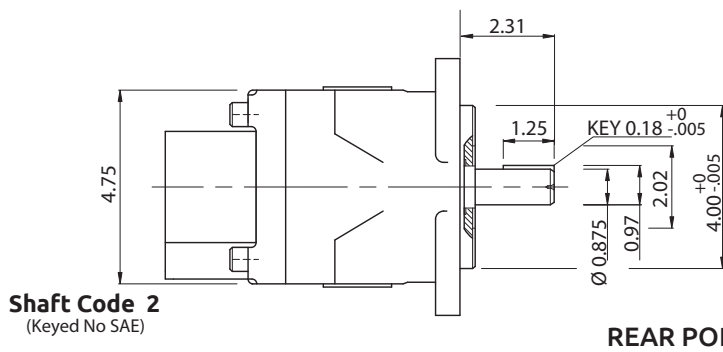

REAR PORTS

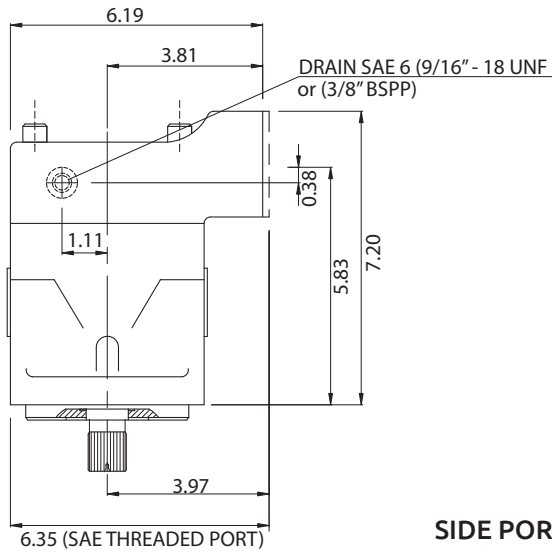
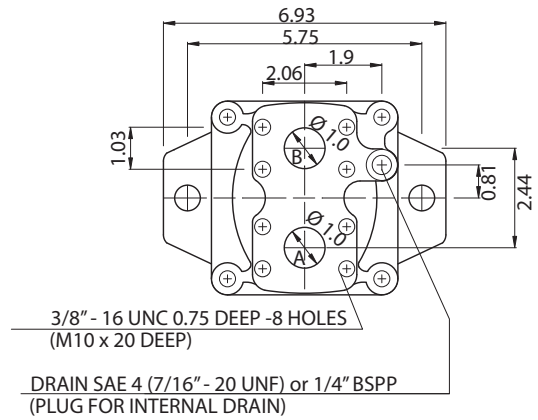

SIDE PORTS

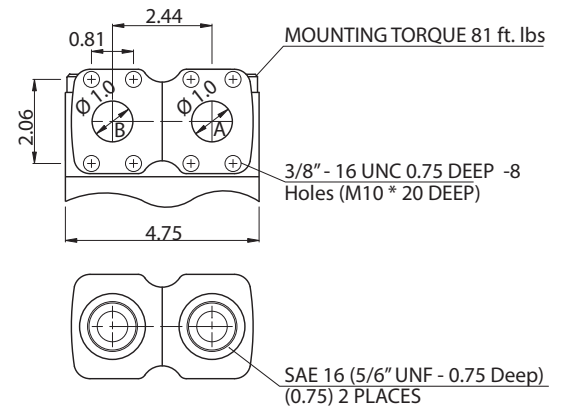

SAE THREADED PORT

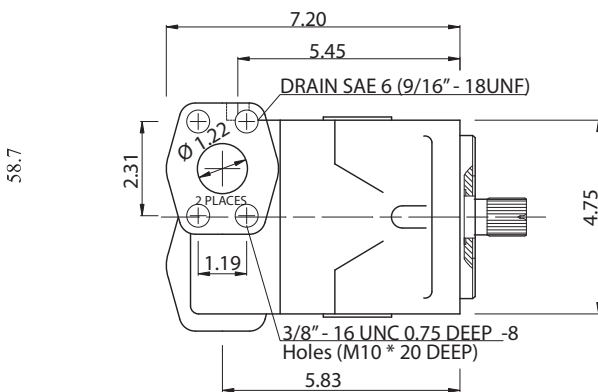

OPPOSITE PORTS

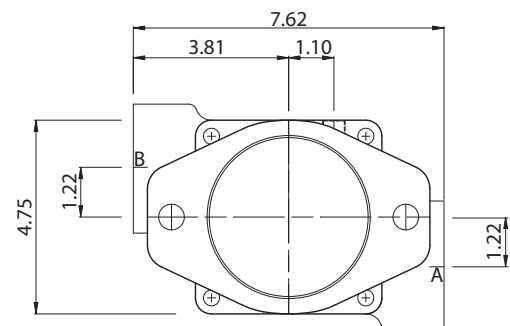



PM4D Ordering Code

PM4*D1 \ PM4*D - 138 - 1 N 00 - B 1 02 *
 ① ② ③ ④ ⑤ ⑥ ⑦ ⑧ ⑨ ⑩

① **Series internal drain**

② **Series external drain**

PM4*D1/PM4*D - SAE-C 2 & 4 Bolt Mount

③ **Torque**

- 062 = 0.63 in.lb/PSI (1.04 Nm/bar)
- 074 = 0.75 in.lb/PSI (1.22 Nm/bar)
- 088 = 0.88 in.lb/PSI (1.45 Nm/bar)
- 102 = 0.96 in.lb/PSI (1.68 Nm/bar)
- 113 = 1.13 in.lb/PSI (1.86 Nm/bar)
- 128 = 1.28 in.lb/PSI (2.11 Nm/bar)
- 138 = 1.40 in.lb/PSI (2.30 Nm/bar)

④ **Type of Shaft**

- 1 = Keyed (SAE C)
- 3 = Splined (SAE C)
- S = Splined (SAE C)

⑤ **Rotation**

N = Bi-directional

*S = Severe duty motor
(Heavy Duty Rotor & Cam Ring)

View from shaft end

CW rotation A=inlet B=outlet
CCW rotation A=outlet B=inlet

⑥ **Porting Combination**

00 = standard

⑦ **Design Letter**

⑧ **Seal Class**

1=HNBR

⑨ **Port Connections**

- 01 = SAE threaded port
SAE drain
- 02= SAE 4 bolt flange
UNC threaded- SAE drain
- 04= SAE 4 bolt flange
UNC threaded- BSPP drain
- M4= SAE 4 bolt flange
Metric threaded- BSPP drain

⑩ **Modifications**

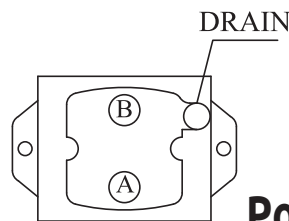

Porting Combination
00 = standard

OPERATING CHARACTERISTICS - TYPICAL 115 SUS (24 cSt)

Model	Series	Volumetric Displacement		Input flow at n = 2000 RPM		Torque T at n = 2000 RPM		Power output at n = 2000 RPM			
		in ³ /rev	cm ³ /rev	Theoretical GPM (lpm)	2500 PSI (175 Bar) Δ p GPM (lpm)	2500 PSI (175 Bar) Δ p in.lbs (Nm)	2500 PSI (175 Bar) Δ p HP (KW)				
PM4D	062	3.97	(65.1)	34.34	(130.0)	40.68	(154.0)	1460.18	(165.0)	46.40	(34.6)
	074	4.69	(76.8)	40.68	(154.0)	47.02	(178.0)	1769.92	(200.0)	56.19	(41.9)
	088	5.56	(91.1)	48.08	(182.0)	54.42	(206.0)	2088.50	(236.0)	66.25	(49.4)
PM4SD	102	6.44	(105.5)	55.74	(211.0)	63.67	(241.0)	2336.29	(264.0)	74.16	(55.3)
	113	7.12	(116.7)	61.55	(233.0)	67.89	(257.0)	2654.88	(300.0)	84.22	(62.8)
	128	8.08	(132.4)	70.01	(265.0)	76.35	(289.0)	3008.86	(340.0)	95.48	(71.2)
	138	8.81	(144.4)	76.35	(289.0)	82.69	(313.0)	3292.05	(372.0)	104.47	(77.9)



PM4D DIMENSIONAL DRAWING

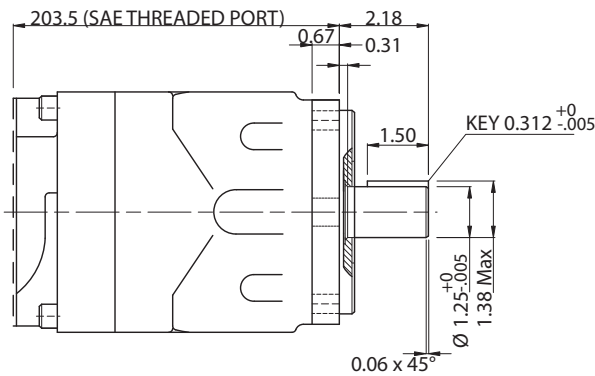

Shaft Code 1
(Keyed SAE C)

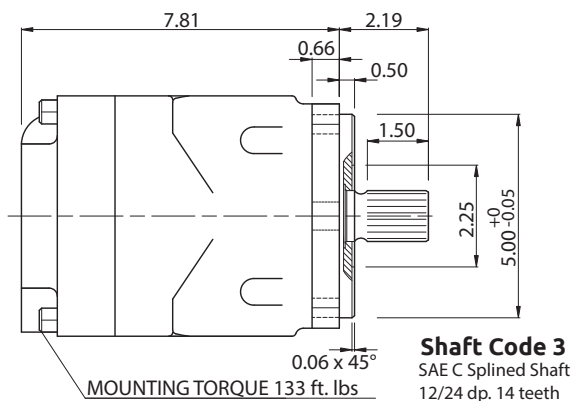
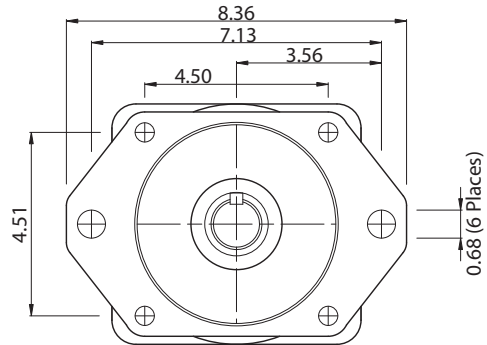

Shaft Code 3
SAE C Splined Shaft
12/24 dp. 14 teeth
30° pressure angle
Flat root side fit

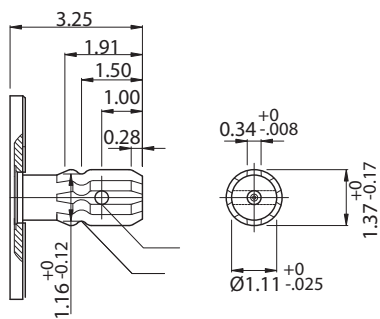
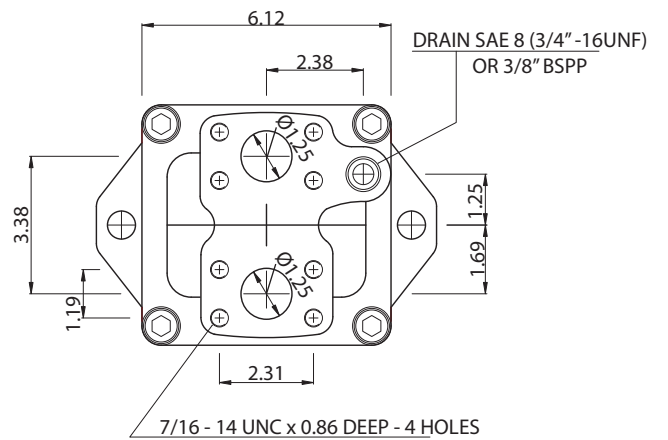

Shaft Code S
SAE J718C
540 rpm power take-off
Farm Tractor Application

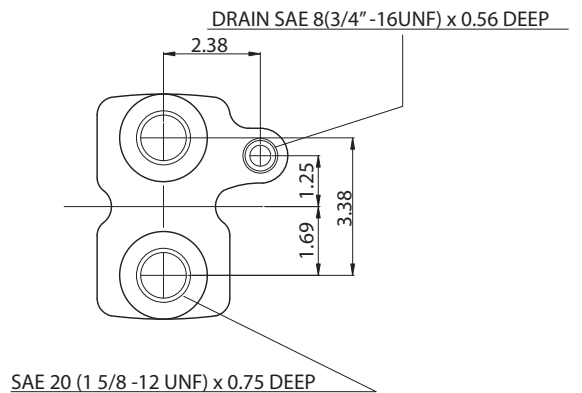

SAE THREADED PORT



PM4E Ordering Code

PM4*E1 \ PM4*E - 214 - 1 N 00 - B 1 02 *
 ① ② ③ ④ ⑤ ⑥ ⑦ ⑧ ⑨ ⑩

① **Series internal drain**

② **Series external drain**

PM4*E1/PM4*E - SAE-C 2 & 4 Bolt Mount

③ **Torque**

153 = 1.54 in.lb/PSI (2.52 Nm/bar)

185 = 1.86 in.lb/PSI (3.05 Nm/bar)

214 = 2.16 in.lb/PSI (3.53 Nm/bar)

④ **Type of Shaft**

1 = Keyed (SAE C)

3 = Splined (SAE C)

⑤ **Rotation**

N = Bi-directional

*S = Severe duty motor
(Heavy Duty Rotor & Cam Ring)

View from shaft end

CW rotation A=inlet B=outlet
CCW rotation A=outlet B=inlet

⑥ **Porting Combination**

00 = standard

⑦ **Design Letter**

⑧ **Seal Class**

1=HNBR

⑨ **Port Connections**

01 = SAE threaded port
SAE drain

02= SAE 4 bolt flange
UNC threaded- SAE drain

04= SAE 4 bolt flange
UNC threaded- BSPP drain

⑩ **Modifications**

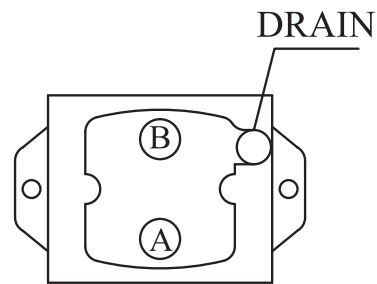

00

Porting Combination 00 = standard

OPERATING CHARACTERISTICS - TYPICAL 115 SUS (24 cSt)

Model	Series	Volumetric Displacement		Input flow at n = 2000 RPM		Torque T at n = 2000 RPM		Power output at n = 2000 RPM			
		in ³ /rev	cm ³ /rev	Theoretical GPM	2500 PSI (175 Bar) Δp (lpm)	2500 PSI (175 Bar) Δp in.lbs	2500 PSI (175 Bar) Δp (Nm)	2500 PSI (175 Bar) Δp HP	2500 PSI (175 Bar) Δp (KW)		
PM4E PM4SE	153	9.67	(158.5)	83.58	(316.4)	90.61	(343.0)	3522.14	(398.0)	111.84	(83.4)
	185	11.69	(191.6)	101.05	(382.5)	108.05	(409.0)	4283.20	(484.0)	135.98	(101.4)
	214	13.55	(222.0)	117.13	(443.4)	124.16	(470.0)	5017.72	(567.0)	159.31	(118.8)



PM4E DIMENSIONAL DRAWING

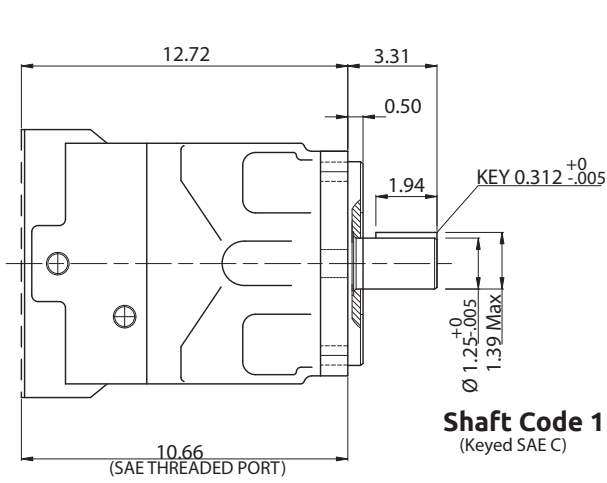

Shaft Code 1
(Keyed SAE C)

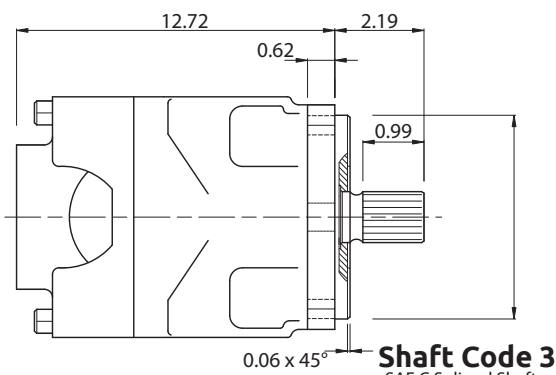
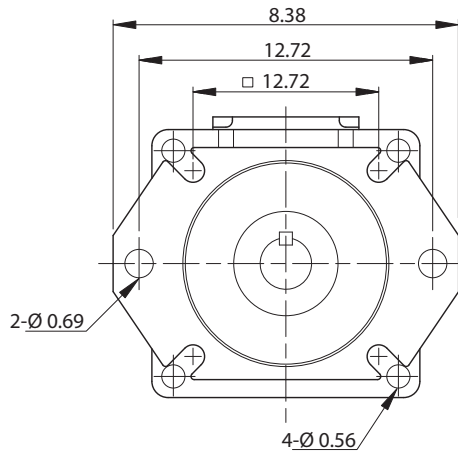

Shaft Code 3
SAE C Splined Shaft
12/24 dp. 14 teeth
30° pressure angle
Flat root side fit

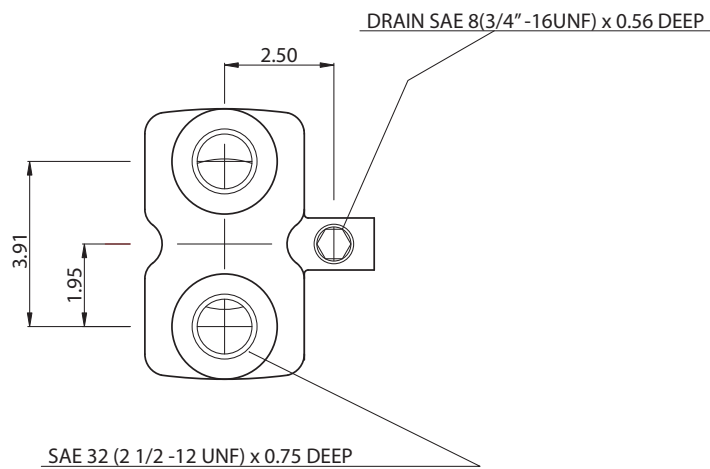
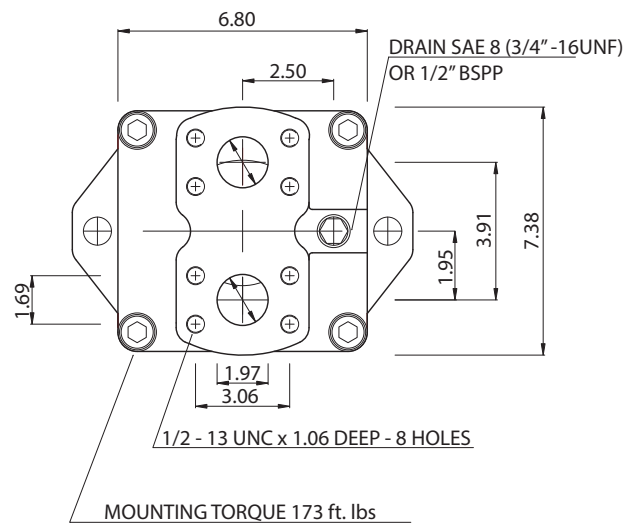

SAE THREADED PORT



HYDRAULIC FLUIDS AND SHAFTS PT6/PT7 SERIES INDUSTRIAL AND MOBILE APPLICATION

RECOMMENDED FLUIDS	Petroleum based antiwear R & O fluids. These fluids are the recommended fluids for PT6 series pumps. Maximum catalog ratings and performance data are based on operation with these fluids. These fluids are covered by Permco HF-0 and HF-2 specification.														
ACCEPTABLE ALTERNATE FLUIDS	The use of fluids other than petroleum based antiwear R & O fluids, requires that the maximum ratings of the pumps are reduced. In some cases the minimum replenishment pressures must be increased. Contact support@permco.com for more details.														
VISCOSITY	<table style="width: 100%; border: none;"> <tr> <td style="width: 70%;">Max (cold start, low speed & pressure) industrial pump</td> <td style="text-align: right;">860 mm /s (cSt),²3900 SUS</td> </tr> <tr> <td>Max (cold start, low speed & pressure) mobile pump</td> <td style="text-align: right;">2000 mm /s (cSt), 9240 SUS</td> </tr> <tr> <td>Max (full speed & pressure)</td> <td style="text-align: right;">108 mm /s (cSt),²500 SUS</td> </tr> <tr> <td>Optimum (max. life)</td> <td style="text-align: right;">30 mm /s (cSt),²140 SUS</td> </tr> <tr> <td>Min (full speed & pressure for HF-1, HF-3, HF-4 & HF-5 fluids)</td> <td style="text-align: right;">-18 mm /s (cSt),²90 SUS</td> </tr> <tr> <td>Min (full speed & pressure for HF-0 & HF-2 fluids)</td> <td style="text-align: right;">10 mm /s (cSt),²60 SUS</td> </tr> </table>	Max (cold start, low speed & pressure) industrial pump	860 mm /s (cSt), ² 3900 SUS	Max (cold start, low speed & pressure) mobile pump	2000 mm /s (cSt), 9240 SUS	Max (full speed & pressure)	108 mm /s (cSt), ² 500 SUS	Optimum (max. life)	30 mm /s (cSt), ² 140 SUS	Min (full speed & pressure for HF-1, HF-3, HF-4 & HF-5 fluids)	-18 mm /s (cSt), ² 90 SUS	Min (full speed & pressure for HF-0 & HF-2 fluids)	10 mm /s (cSt), ² 60 SUS		
Max (cold start, low speed & pressure) industrial pump	860 mm /s (cSt), ² 3900 SUS														
Max (cold start, low speed & pressure) mobile pump	2000 mm /s (cSt), 9240 SUS														
Max (full speed & pressure)	108 mm /s (cSt), ² 500 SUS														
Optimum (max. life)	30 mm /s (cSt), ² 140 SUS														
Min (full speed & pressure for HF-1, HF-3, HF-4 & HF-5 fluids)	-18 mm /s (cSt), ² 90 SUS														
Min (full speed & pressure for HF-0 & HF-2 fluids)	10 mm /s (cSt), ² 60 SUS														
VISCOSITY INDEX	<p>90° min, higher values extend range of operation temperatures.</p> <p>Maximum fluid temperature (0)°K (+ 0°C, + 0 °F)</p> <table style="width: 100%; border: none;"> <tr> <td style="width: 70%;">HF-0, HF-1, HF-2</td> <td style="text-align: right;">373 (+ 100°C, + 212 °F)</td> </tr> <tr> <td>HF-3, HF-4</td> <td style="text-align: right;">323 (+ 50°C, + 122 °F)</td> </tr> <tr> <td>HF-5</td> <td style="text-align: right;">343 (+ 70°C, + 158 °F)</td> </tr> <tr> <td>Biodegradable fluids (esters & rapeseed base)</td> <td style="text-align: right;">338 (+ 65°C, + 149 °F)</td> </tr> </table> <p>Minimum fluid temperature (0)°K (+ 0°C, + 0 °F)</p> <table style="width: 100%; border: none;"> <tr> <td style="width: 70%;">HF-0, HF-1, HF-2, HF-5</td> <td style="text-align: right;">255 (+ 18°C, + 0.4 °F)</td> </tr> <tr> <td>HF-3, HF-4</td> <td style="text-align: right;">283 (+ 10°C, + 50 °F)</td> </tr> <tr> <td>Biodegradable fluids (esters & rapeseed base)</td> <td style="text-align: right;">253 (+ 20.2°C, + 4.4 °F)</td> </tr> </table>	HF-0, HF-1, HF-2	373 (+ 100°C, + 212 °F)	HF-3, HF-4	323 (+ 50°C, + 122 °F)	HF-5	343 (+ 70°C, + 158 °F)	Biodegradable fluids (esters & rapeseed base)	338 (+ 65°C, + 149 °F)	HF-0, HF-1, HF-2, HF-5	255 (+ 18°C, + 0.4 °F)	HF-3, HF-4	283 (+ 10°C, + 50 °F)	Biodegradable fluids (esters & rapeseed base)	253 (+ 20.2°C, + 4.4 °F)
HF-0, HF-1, HF-2	373 (+ 100°C, + 212 °F)														
HF-3, HF-4	323 (+ 50°C, + 122 °F)														
HF-5	343 (+ 70°C, + 158 °F)														
Biodegradable fluids (esters & rapeseed base)	338 (+ 65°C, + 149 °F)														
HF-0, HF-1, HF-2, HF-5	255 (+ 18°C, + 0.4 °F)														
HF-3, HF-4	283 (+ 10°C, + 50 °F)														
Biodegradable fluids (esters & rapeseed base)	253 (+ 20.2°C, + 4.4 °F)														
FLUID CLEANLINESS	The fluid must be cleaned before and during operation to maintain contamination level of NAS1638 class 8 (or ISO 18/14) or better. Filters with 25 micron (or better, B10 100) nominal ratings may be adequate but do not guarantee the required cleanliness levels. Suction strainers must be of adequate size to provide minimum inlet pressure specified. 100 mesh (149 micron) is the finest mesh recommended. Use oversize strainers or omit them altogether on applications which require cold starts or use fire resistant fluids.														
OPERATING TEMPERATURES	Operating temperatures are a function of fluid viscosities, fluid type, and the pump. Fluid viscosity should be selected to provide optimum viscosity at normal operating temperatures. For cold starts the pumps should be operated at low speed and pressure until fluid warms up to an acceptable viscosity for full power operation.														
WATER CONTAMINATION IN THE FLUID	<p>Maximum acceptable content of water.</p> <ul style="list-style-type: none"> • 0.10% for mineral base fluids. • 0.05% for synthetic fluids, crankcase oils, biodegradable fluids. <p>If amount of water is high then it should be drained off the circuit.</p>														
COUPLINGS AND FEMALE SPLINES	<p>The mating female spline should be free to float and find its own center. If both members are rigidly supported they must be aligned within 0.15mm (0.006") TIR or less to reduce fretting. The angular alignment of two spline axes must be less than ±0.05 per 25.4mm(±0.002" per 1"radius). The coupling must be hardened to a hardness between 27 and 45 R.C. The female spline must be made to conform to the Class 1 fit as described in SAE-J498b (1971). This is described as a Flat Root Side Fit.</p>														
KEYED SHAFTS	Permco supplies the PT series Keyed shaft pumps with high strength heat-treated keys. Therefore, when installing or replacing these pumps, the heat-treated keys must be used in order to insure maximum life in the application. If the key is replaced it must be a heat-treated key between 27 and 34 R.C. hardness. The corners of the keys must be chamfered from 0.03" to 0.04" (0.76mm to 1.02mm) at 45° to clear radii in the key way.														
NOTE	Alignment of keyed shafts must be within tolerances given for splined shafts														
SHAFT	These products are designed primarily for coaxial drives which do not impose axial or side loading on the shaft. Contact support@permco.com for more details.														



PUMP SELECTION AND PRESSURE RATING DESCRIPTION PT6/PT7 SERIES INDUSTRIAL AND MOBILE APPLICATION

PUMP CALCULATIONS

To Resolve:

Initial displacement: V_i (cm³/rev)
(based on requested flow)
Input power P (kW)

Required Performance:

Requested flow: Q (l/min) 60
Speed: n (RPM) 1500
Pressure: p (Bar) 150

FORMULA AND EXAMPLE

V_p = Volumetric displacement
 Q_a = Actual pump flow @ operating condition
 Q_{th} = Theoretical flow of pump chosen at RPM
 Q_s = Pump internal leakage
 P_s = Power Loss
 P_i = Theoretical input power

Formula:

1. First calculation $V_i = \frac{1000 Q}{n}$
2. Choose V_p of pump with next highest displacement (see chart tabulations) ($V_p > V_i$)
3. Theoretical flow of this pump

$$Q_{th} = \frac{V_p \times n}{1000}$$

4. Find Q_s leakage function of pressure $Q_s = f(p)$ on curve at 10 or 24 cSt (see chart page 15)

5. Available flow $Q_a = Q_{th} - Q_s$

6. Theoretical input power

$$P_i = \frac{Q_{th} \times p}{600}$$

7. Find P_s hydrodynamic power loss on curve (see chart page 15)

8. Calculation of necessary input power $P = P_i + P_s$

9. Results

Example:

$$V_i = \frac{1000 \times 60}{1500} = 40 \text{ cm}^3/\text{rev}$$

$$PT6C-014 \ V_p = 46 \text{ cm}^3/\text{rev}$$

$$Q_{th} = \frac{46 \times 1500}{1000} = 69 \text{ l/min}$$

PT6C (pages 15-16): $Q_s = 5 \text{ l/min}$ at 150 BAR, 24 cSt

$$Q_a = 69 - 5 = 64 \text{ l/min}$$

$$P_i = \frac{69 \times 150}{600} = 17.3 \text{ kW}$$

PT6C (pages 15-16): P_s at 1500 RPM, 150 BAR = 1.5 kW

$$P = 17.3 + 1.5 = 18.8 \text{ kW}$$

$$\left. \begin{array}{l} V_p = 46.0 \text{ cm}^3/\text{rev} \\ V_a = 64.0 \text{ l/min} \\ P = 18.8 \text{ kW} \end{array} \right\} \text{PT6C-014}$$

If Q_a is close enough to Q then done
If Q_a is too low choose PT6C-017
If Q_a is too high choose PT6C-012

INTERMITTENT PRESSURE RATING

Pressure (BAR)

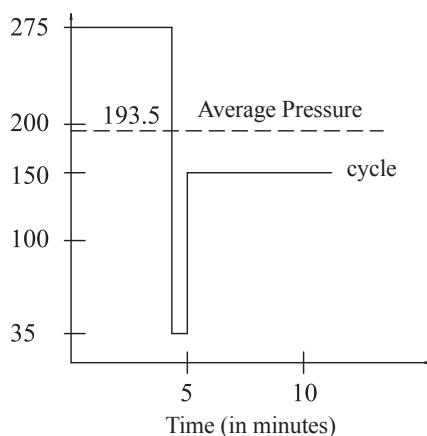

PT6 and PT7 units may be operated intermittently at pressures higher than the recommended continuous rating when the time weighted average of pressure is less than or equal to the continuous duty pressure rating.

This intermittent pressure rating calculation is only valid if other parameter, speed, fluid, viscosity and contamination levels are respected.

For total cycle time higher than 15 minutes please consult factory or your local Permco representative.

Example: PT6C-014

Duty cycle 4 minutes at 275 Bar
1 minute at 35 Bar
5 minutes at 160 Bar

$$\frac{(4 \times 275) + (1 \times 35) + (5 \times 160)}{10} = 193.5 \text{ Bar}$$

193.5 Bar is lower than 240 BAR allowed as continuous pressure for PT6C-014 with HF-0 fluid.

Throughout this catalog you will find dimensions, flows, power, pressures and loads in metric terms, to convert please use the following conversion guide.

To convert mm to inches divide by 25.4

To convert liters into gallons multiply by .2642

To convert bar to PSI multiply by 14.5

10 cSt = 60 SUS and 24 cSt = 115 SUS

To convert KW to HP multiply by 1.341

To convert newtons to pounds force multiply by .2248

To convert cm³/rev to in³/rev divide by 16.387

Industrial Version Solid Pin Design (EX: PT6C)

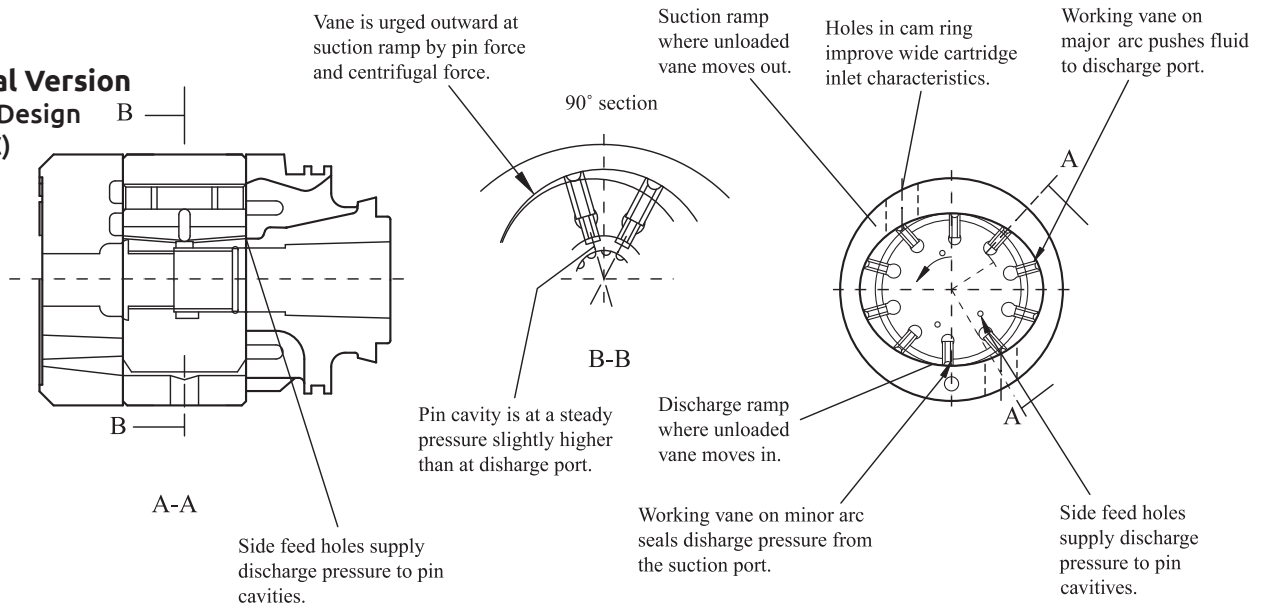

Mobile Version* Thru-Pin Design (EX: PT6CM)

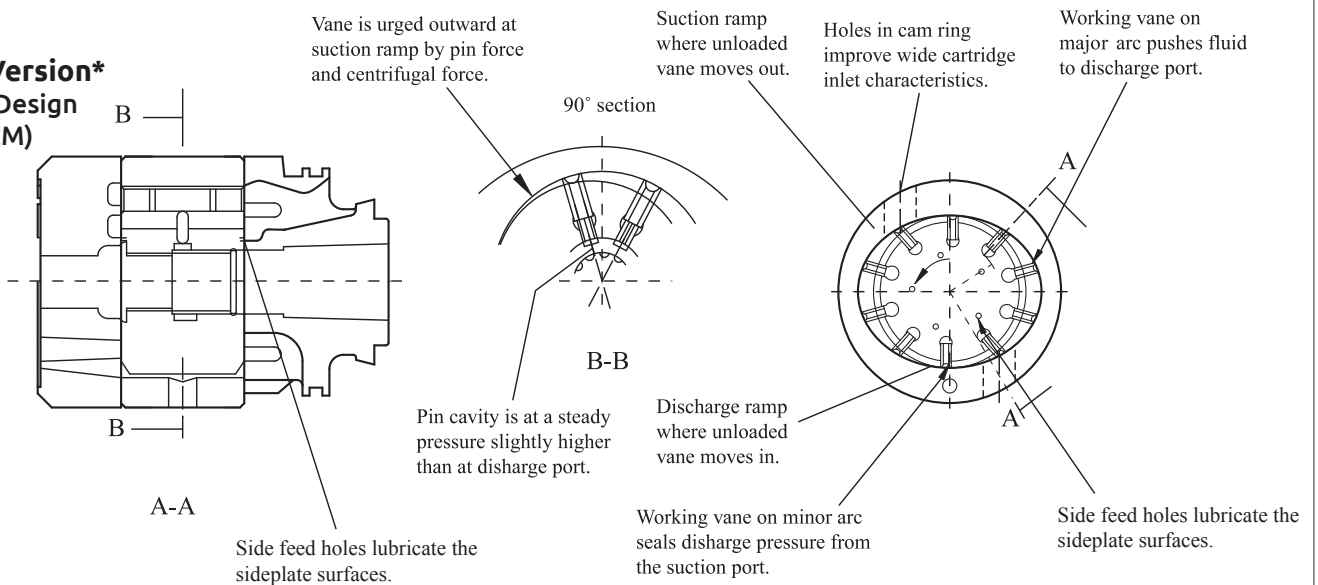

* "M" in a model number represents mobile cartridge setup

APPLICATION ADVANTAGES

- The high pressure capability up to 4650 PSI (320 Bar), in the small envelope, reduces installation costs and provides extended life at reduced pressure.
- The wide speed range from 600 RPM to 2800 RPM, combined with large size cartridge displacements, will optimize operation for the lowest noise level in the smallest envelope.
- The low speed 600 RPM, low pressure, high viscosity 860 cSt (3900 SUS) allow applications in cold environments with a minimum energy consumption and without risk of seizure.
- The low ripple pressure ± 29 PSI (± 2 Bar) reduces piping noise and increases life time of other components in the circuit.
- The high resistance to particle contamination because of the double lip vane increases pump life.
- The large variety of options (cam displacement, shaft, porting) allows customized installation.



Viscosity Conversion Chart / Torque Specifications

Viscosity Conversion Chart

Millipascal Seconds (mPas)/ Centistokes (cSt)	Saybolt Seconds Universal (SSU)
1	31
10	60
30	160
60	320
100	530
160	790
220	1100
280	1380
360	1730
480	2380
700	3380

Millipascal Seconds (mPas)/ Centistokes (cSt)	Saybolt Seconds Universal (SSU)
1000	4600
1600	7500
2200	10300
3500	16500
6000	28000
15000	69400
50000	231000
100000	462000
150000	694000
200000	925000

Torque Specifications

Model	Front section # of bolts	torque ft-lbs.	2nd Section # of bolts	torque ft-lbs.	3rd Section # of bolts	torque ft-lbs.
PT6C/PT6CM	4	117				
PT6D/PT6DM	4	138				
PT6E/PT6EM	4	138				
PT6CC/PT6CCM	4	117	7	47		
PT6DC/PT6DCM	4	138	7	47		
PT6DDS/PT6DDSM	4	138	4	138		
PT6EC/PT6ECM	4	138	7	47		
PT6ED/PT6EDM	4	138	4	138		
PT6EE/PT6EES	4	221	4	221		
PT6DCC/PT6DCCM	4	138	4	138	7	47
PT6DDC/PT6DDCS	4	138	4	138	7	47
PT6EDC/PT6EDCS	4	221	4	221	7	47
PT7B/PT7BS	4	138				
PT7D/PT7DS	4	138				
PT7E/PT7ES	4	138				
PM4C	4	75				
PM4D	4	135				
PM4E	4	175				
PT6GC	4	117				
PT6GCC	4	117				

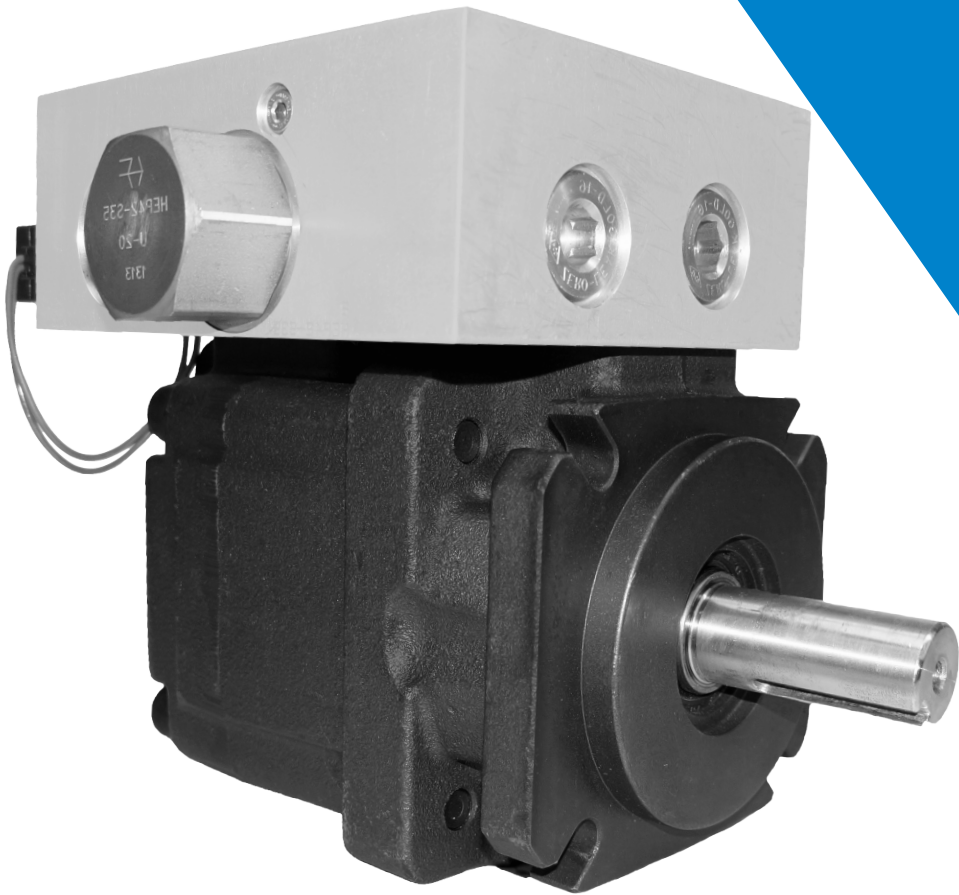

PERMCO

**1500 Frost Rd.
P.O. Box 2068
Streetsboro, OH 44262**

**☎ 330.626.2801
✉ support@permco.com
permco.com**