

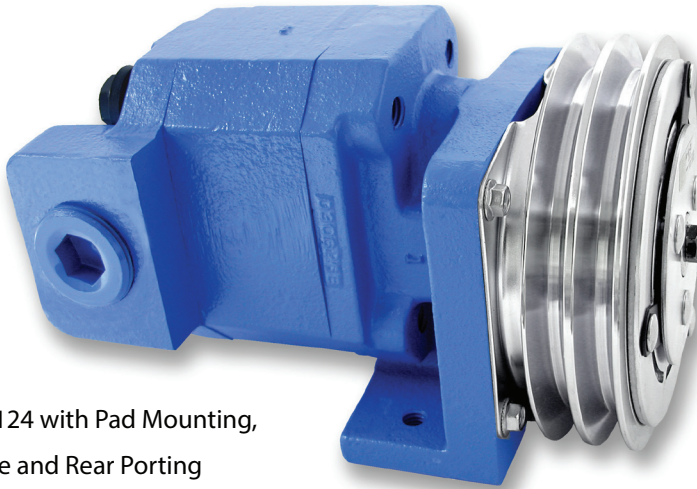

CLUTCH PUMPS

CP124 CLUTCH PUMPS AND ACCESSORIES



CP124 with Pad Mounting,
Side and Rear Porting

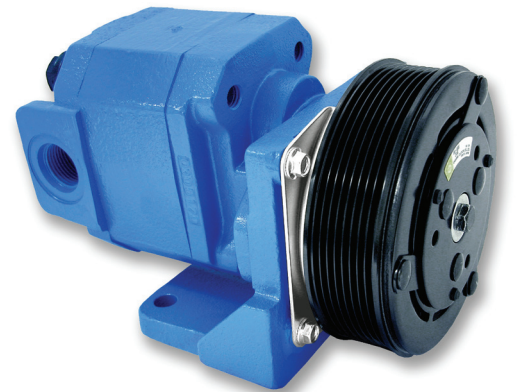

CP124 with
Bracket Mount, Side SAE O-ring Ports

CP124 CLUTCH PUMP SERIES FEATURES

- ❑ Cubic inch displacements from 0.62 through 2.48
- ❑ Speeds to 3000 RPM and pressures to 3500 PSI
- ❑ SAE "A" mounting with bracket or Pad mounting available
- ❑ Heavy duty sleeve bushing design in a small frame size
- ❑ Doweled and high strength 3 piece cast iron construction
- ❑ 100% factory tested
- ❑ High strength alloy steel gear and shaft set
- ❑ NPT, O'ring, or split flange porting located on the rear and/or side
- ❑ Only high torque clutches used with all the popular clutch configurations available
- ❑ Pressure balanced wear plates maintain high pump efficiency throughout all operating ranges
- ❑ Typical applications include recovery vehicles, snow plows, spreaders, utility vehicles, winches, small hoists, aerial devices, lift gates, cranes, and light duty equipment

GEAR WIDTH (IN)	DISPL CU IN/CC	GPM/LITERS @ 1000 RPM	MAX RPM	MIN RPM	MAX PSI/BAR
.50	.62/10	2.2/8.3	3000	600	3500/241
.75	.93/15	3.6/13.6	3000	600	3500/241
1.00	1.24/20	4.9/18.5	3000	600	3500/241
1.25	1.55/25	6.1/23.1	3000	600	3500/241
1.50	1.86/30	7.4/28.0	3000	600	3200/220
1.75	2.17/35	8.8/33.3	3000	600	2900/200
2.00	2.48/40	10.0/37.9	3000	600	2500/172



National Fluid Power Association
50th Anniversary: 1953 - 2003

The Sensible Choice

CLUTCH PUMP KIT MODEL NUMBER CONSTRUCTION

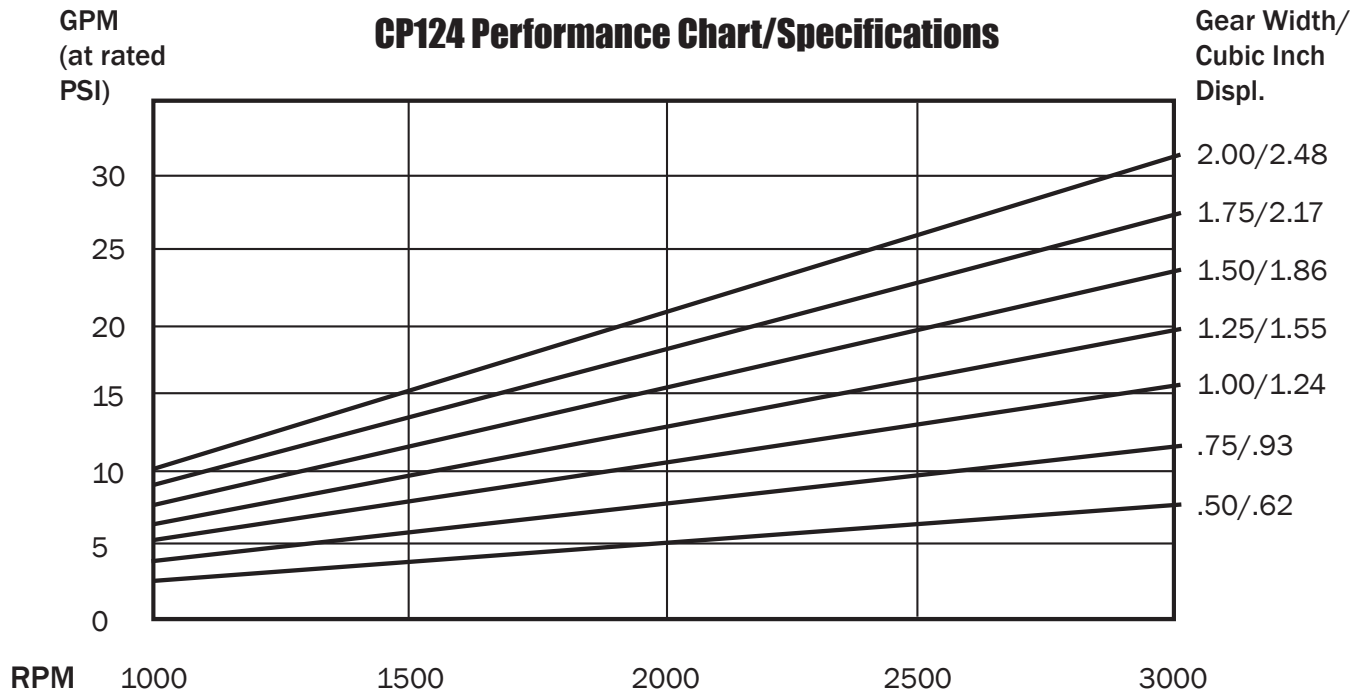
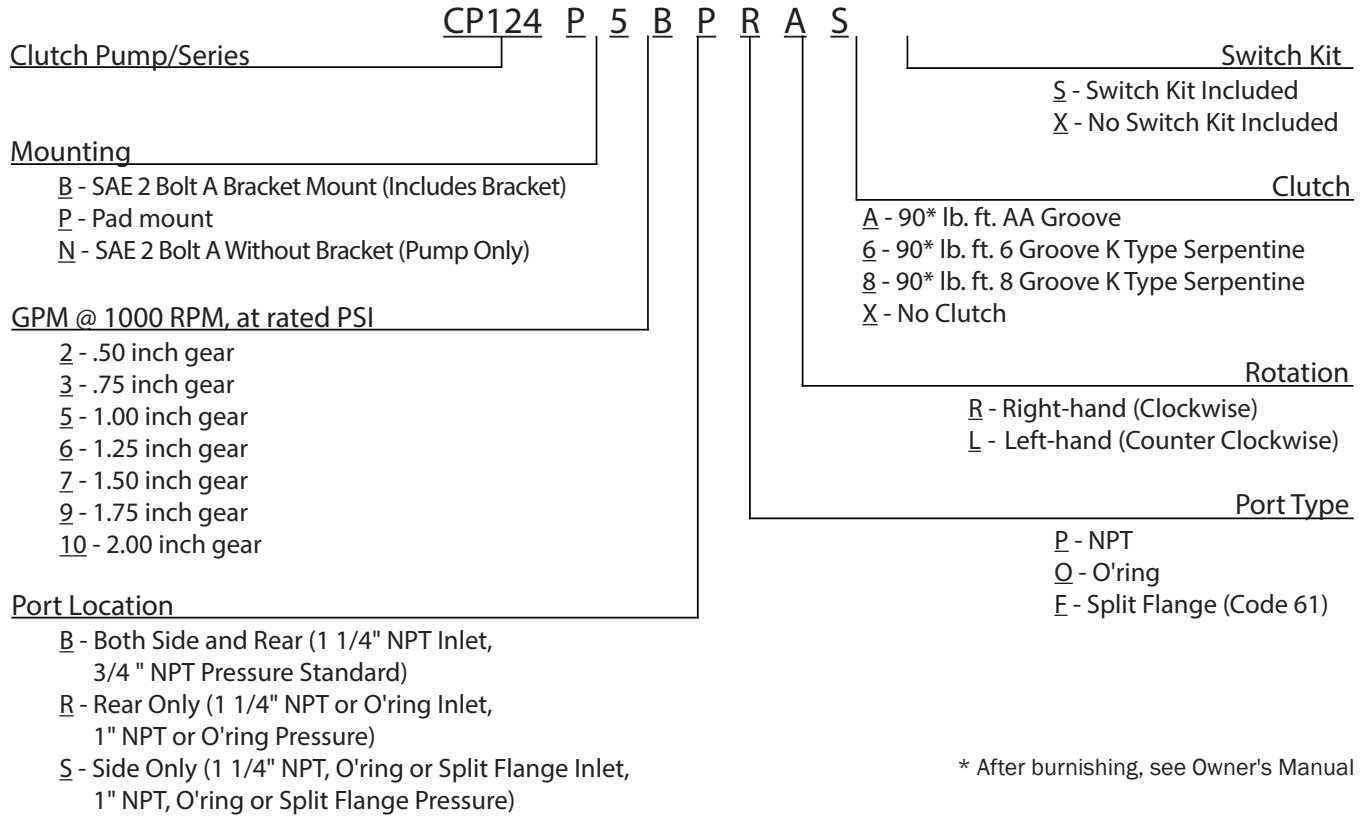

Though the pump and clutch will handle these flows and pressures, belt slippage may occur. Maximum inlet vacuum should not exceed 5 IN. HG.

Dimensional Data (inches/mm)

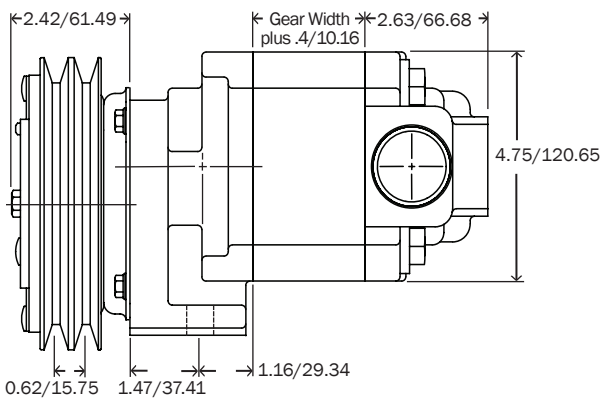
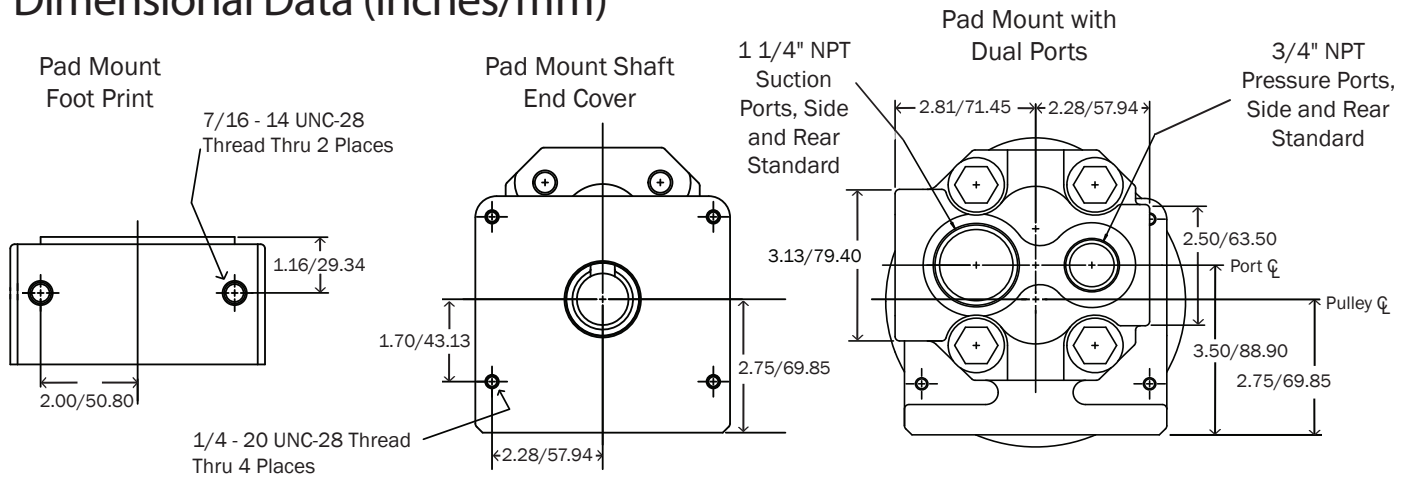

Pad Mount with Dual Ports, AA Groove Clutch

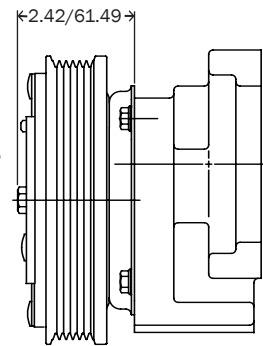

Pad Mount with 6 Groove Serpentine Clutch

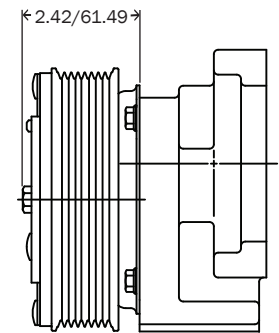

Pad Mount with 8 Groove Serpentine Clutch

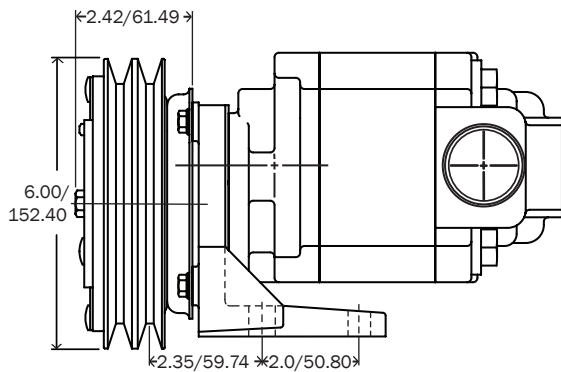

SAE 2 Bolt A with Bracket, Dual Ports, AA Groove Clutch

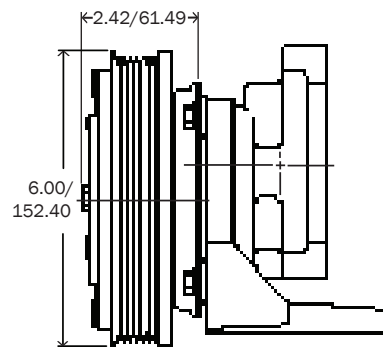

SAE 2 Bolt A with Bracket, 6 Groove Serpentine Clutch

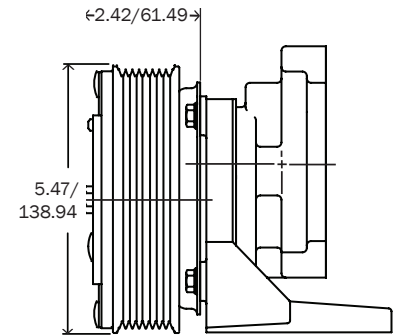

SAE 2 Bolt A with Bracket, 8 Groove Serpentine Clutch

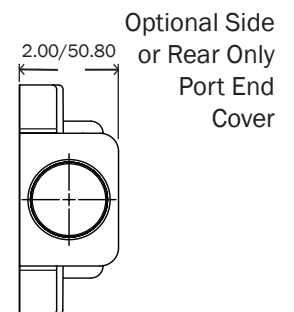
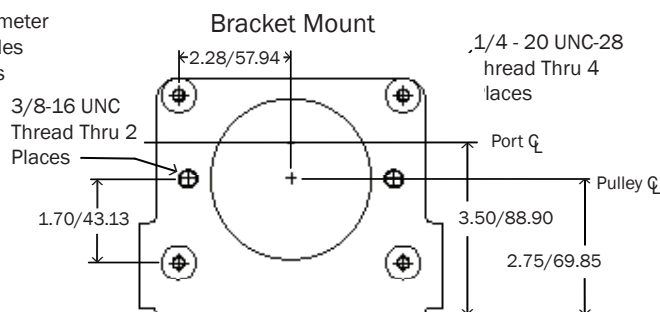
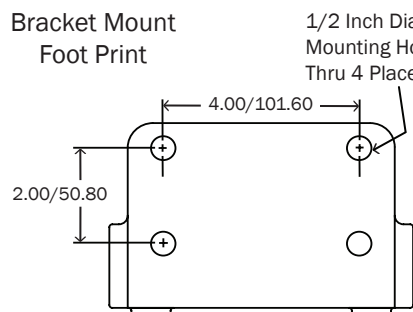

Drawings not necessarily to scale. Permco reserves the right to make changes in an ongoing effort to improve the product.



CLUTCH PUMP SERVICE PARTS



999-00956
Clutch Pump
Switch Kit

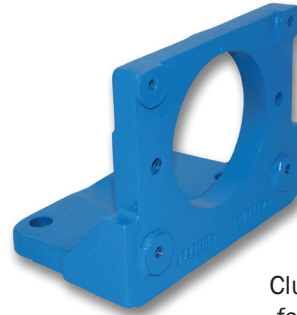

BR549
Clutch Pump Bracket
for 2 Bolt "A" Mount



512010
AA Groove Clutch,
90 lb.ft.*



520226
6 Groove Type K
Serpentine Clutch,
90 lb.ft.*



515376
8 Groove Type K
Serpentine Clutch,
90 lb.ft.*

* After burnishing, see Owner's Manual

Permco Warranty

Permco warrants that its products will not fail due to defects in materials and workmanship. Failure of any product or any one of its components to perform in accordance with design specifications, which failure occurs more than (2) two years or 4,000 hours, whichever is less, from the date of shipment of the product from its point of manufacture, shall be presumed to result from deterioration caused by ordinary use. Permco's obligation in the case of defective workmanship or material is limited to replacement or repair of the defective product, or the defective component therein, at Permco's option, in accordance with the procedures explained herein.

§ This warranty is given in lieu of all other warranties, expressed or implied.

§ There are no warranties which extend beyond the description on the face hereof.

When buyer claims a breach of the limited warranty set forth above, the buyer must notify Permco or its agents promptly, whereupon Permco at its option will either examine the product in question at the site, or issue shipping instructions for its return to Permco or one of its authorized warranty repair centers. Transportation cost must be prepaid by buyer on all returns. Credit for freight in and out, based on surface freight rates will be issued if the inspection of the goods shows a defect in materials or workmanship covered by the limited warranty.

Permco
1500 Frost Rd.
P. O. Box 2068
Streetsboro, OH USA 44241
Phone 330-626-2801
Fax 330-626-2805
e-mail info@permco.com
www.permco.com

Permco (Tianjin) Hydraulic Inc. Ltd.
#92 Hai Bin Wu Lu, Freezone
Tianjin Port, China
Phone 022-25702597, 98, 99
Fax 022-25760830
e-mail permco@permcotj.com
www.permcotj.com

Permco Hydraulik AG
P. O. Box 553
6343 Rotkreuz
Switzerland
Phone +41 (0)41 850 86 65
Fax +41 (0)41 850 86 67
e-mail heinzm@permco.com
© Bulletin #CP12404A