

Heavy & Medium Duty Dump Trucks & Trailers

LIL TIPPER

Precision-Engineered Fluid Power Products

The Sensible Choice for Pumps



Dump Trucks
Walking Floor

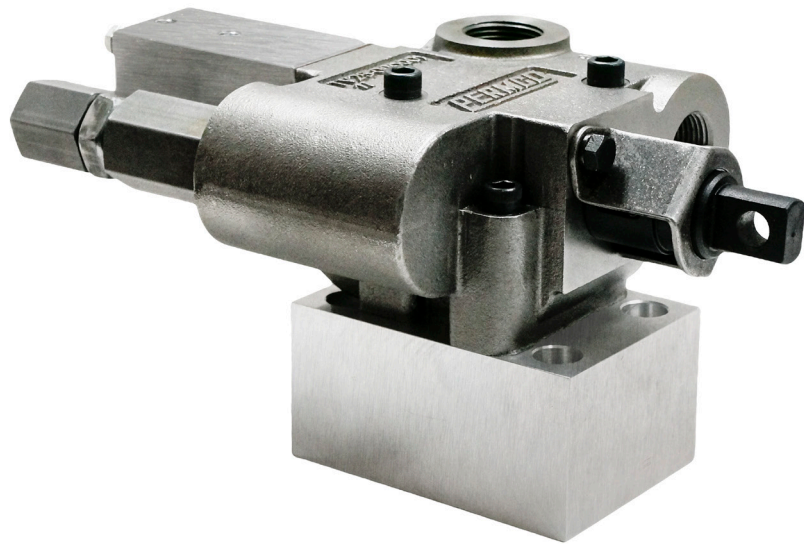

Features

- Pump and cylinder protected in the "Raise" and "Neutral" position of the spool
- Manual shift, factory installed "OE" air, or "Add-on" air shifts each with full metering capabilities
- Built-in load check maintains dump body angle and is installed in the cylinder port for superior self-cleaning
- Built-in direct acting relief valve set at factory
- 100% factory tested
- SAE and NPT ports available
- Neutral lock-out safety cap for use with pull-out cable





Dimensional Data (inches)

| | |
|-----------|-------------------------------|
| P | Outlet (to cylinder) |
| P1 | Inlet (from pump) |
| T | Tank Line (Return to Tank) |

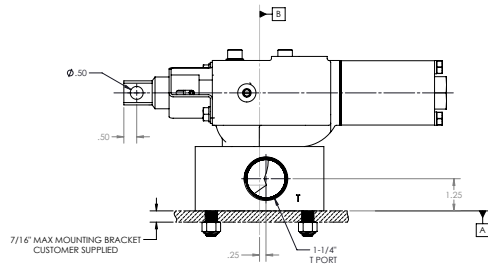
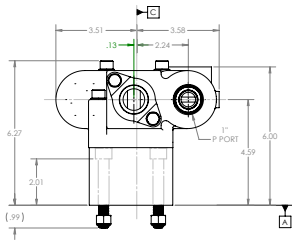
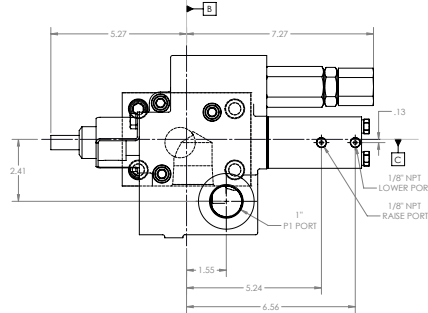

AIR SHIFT

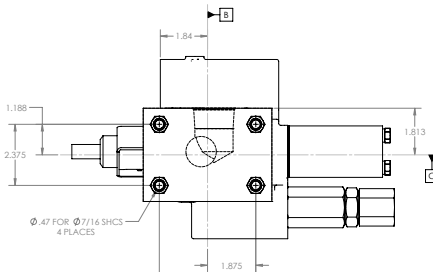
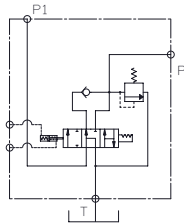

Permco is a leading manufacturer of high-pressure hydraulic gear/vane pumps and motors, flow dividers, intensifiers, and accessories. Available in a wide variety of sizes and configurations to suit your application needs.

Lil Tipper Code

TV - ORB - AS - 1 - **

Pressure Setting

- 20** 2000 psi
- 25** 2500 psi
- 30** 3000 psi
- Blank** Gemini

- 1** RP-5514
- X** RP-5514-3000
- XX/XX** Gemini*

Tipping Valve

NPT - Ports
ORB - Ports

AS Air Shift
MS Manual Shift

*Customer must provide both lower and higher pressure relief settings

Our Online Support is available
24/7/365 for your needs!

Email: support@permco.com

Call: (800) 626.2801



www.permco.com



NFPA
Solutions through
friction technology



Member