

Heavy & Medium Live Floors, Moving Floors & Trailers

DIN GEMINI SERIES

Precision-Engineered Fluid Power Products

The Sensible Choice for Pumps



Dump Trucks
Crane Equipment
Vehicles
Roll Off Trucks
Refuse Collection
Walking Floor

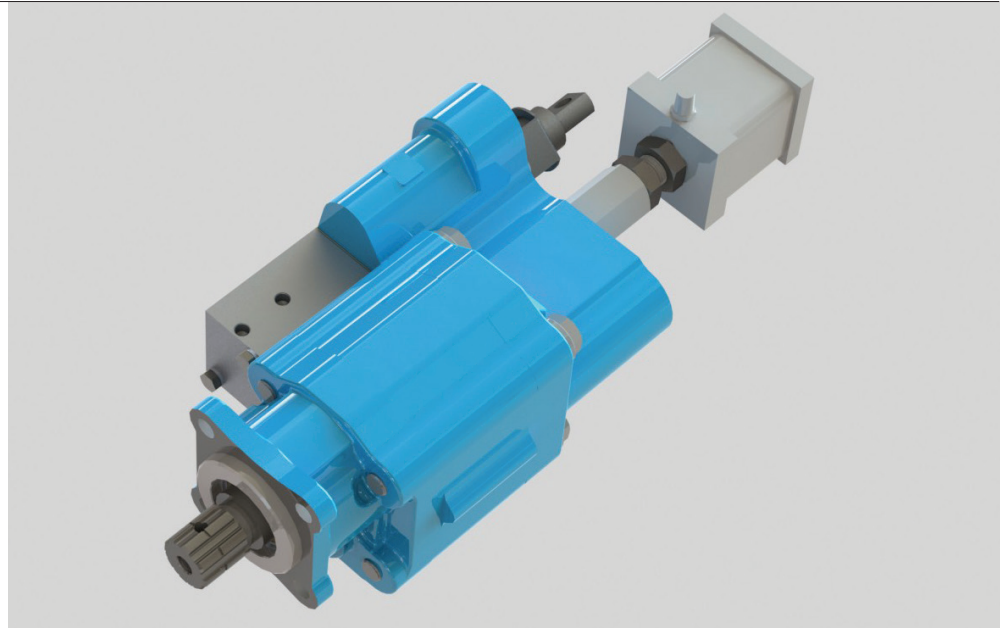

Features

- ISO 7653 4 bolt flange mount Ø80 mm pilot
- DIN 5462 - 8 x 32 x 36 spline shaft
- Easy to switch from low to high pressure using truck air
- Large 1 ½" NPT suction port in the gear housing
- Three line system for continuous duty
- Field adjustable relief settings
- Dowelled construction
- 37 GPM @ 1800 RPM
- 100% factory tested
- NPT ports
- Factory installed "OEM" air shift with full metering capabilities
- Dual Pressure Relief: low for dump bodies, high for live floors
- Relief valve protects the high pressure portion of the system as well as the pump

PERMCO



Dimensional Data (inches)

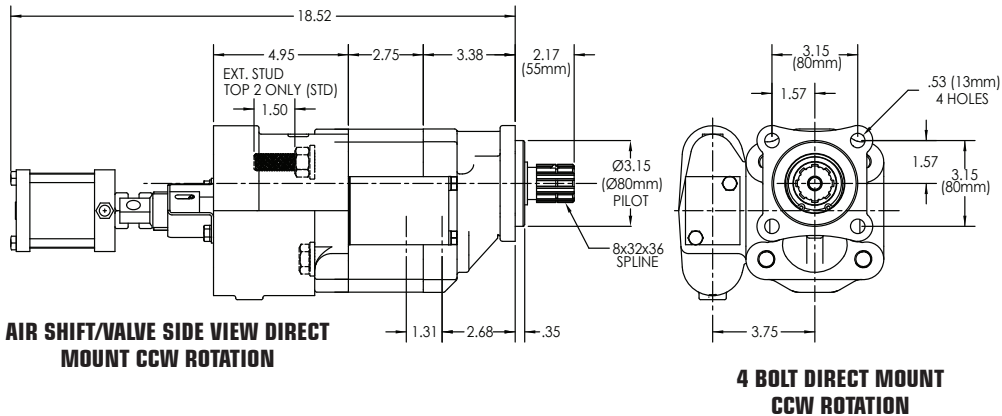
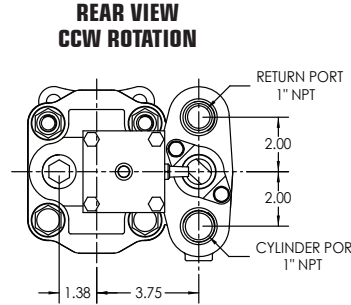
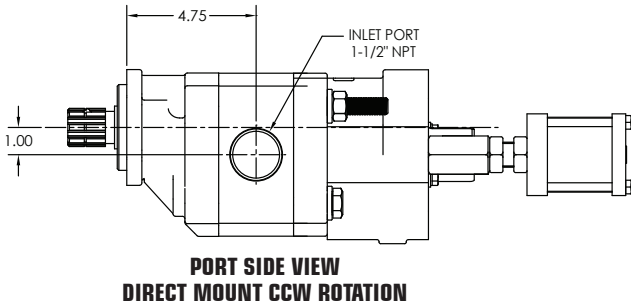

Permco is a leading manufacturer of high-pressure hydraulic gear/vane pumps and motors, flow dividers, intensifiers, and accessories. Available in a wide variety of sizes and configurations to suit your application needs.

Product Information

DGDIN - 20 - Z - L - AS - 25/32 - **

DGDIN ISO 7653 4-Bolt Ø80mm Pilot
DIN 5462 - 8x32x36 Spline

20 20" Gear / 37 GPM at 1800 RPM

Z 3Line Sleeve Installed

L Left Hand Rotation

R Right Hand Rotation

AS *Air Shift of Main Spool

MS Manual Shift of Main Spool

****Extended Stud Orientation**

- Delete** Top Two (Std.)
- EB** Bottom Two
- EL** Left Side
- ER** Right Side
- E4** All four

Relief Valve Setting

- 25** 2500 PSI Low Pressure
- 32** 3200 PSI High Pressure

*Because of potential interference with aftermarket air shift cylinders, we recommend the Permco "OEM" version.

**Our Online Support is available
24/7/365 for your needs!**

Email: support@permco.com

Call: (800) 626.2801



www.permco.com

