

PERMCO

GEMINI

HEAVY DUTY PUMP FOR LIVE FLOORS, MOVING FLOORS, AND DUMP TRAILERS

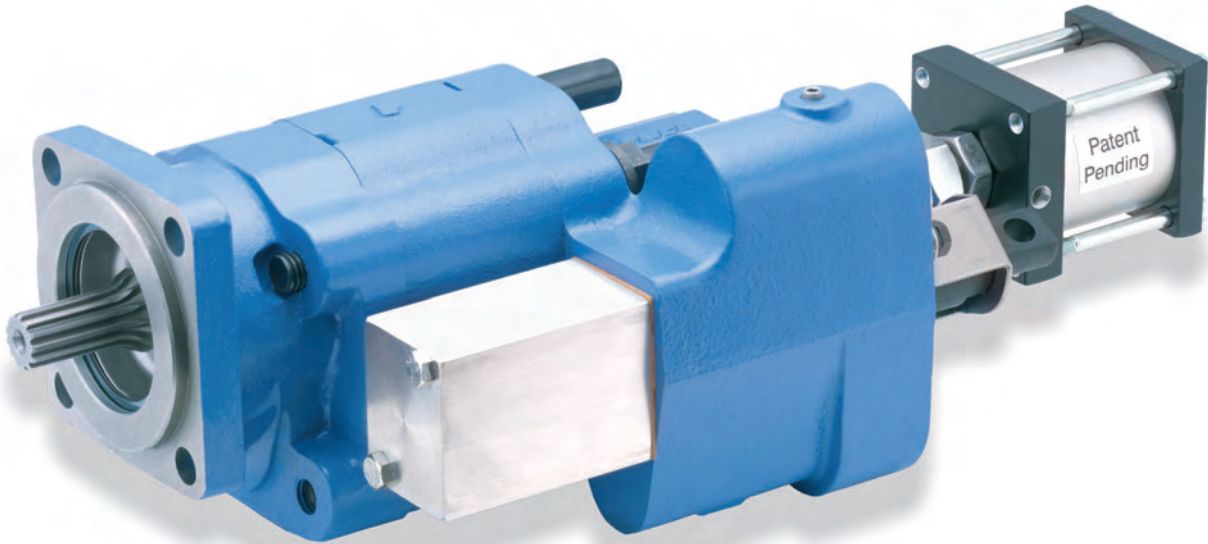

GEMINI FEATURES

- ❑ Dual Pressure Relief: low for dump bodies, high for live floors
- ❑ Easy to switch from low to high pressure using truck air
- ❑ Large 1 ½" NPT suction port in the gear housing
- ❑ Three line system for continuous duty
- ❑ Field adjustable relief settings
- ❑ Dowelled construction
- ❑ 37 GPM @ 1800 RPM
- ❑ 100% factory tested
- ❑ Heavy-duty "controlled stress" roller bearings
- ❑ Factory installed "OEM" air shift with full metering capabilities
- ❑ Direct mount SAE "B" 4 bolt or twin shafted remote mount with bracket
- ❑ Relief valve protects the high pressure portion of the system as well as the pump

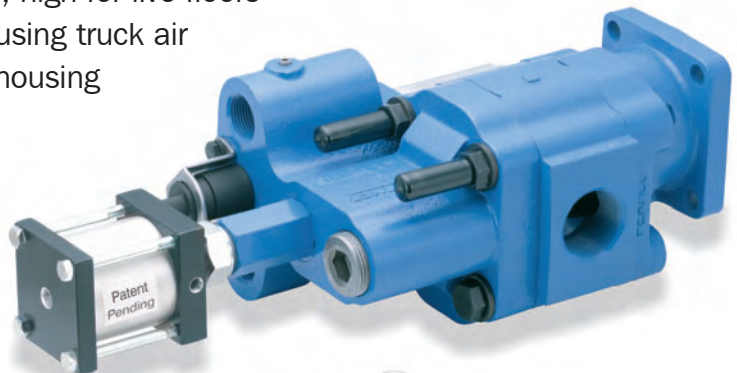

997-01226-8
Air Shift Tower



The Sensible Choice

Dimensional Data (inches)

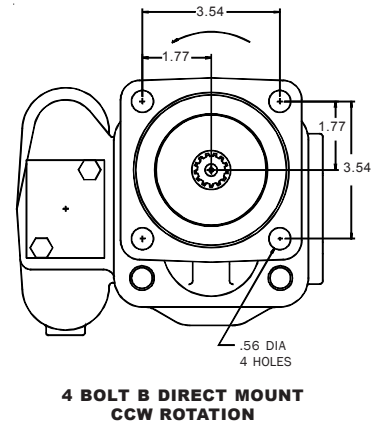
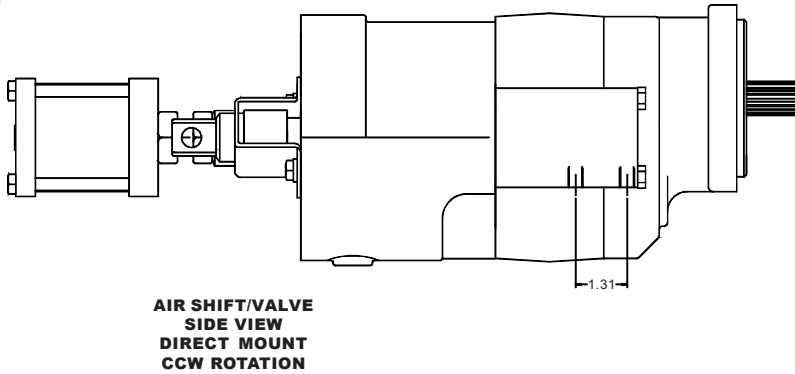
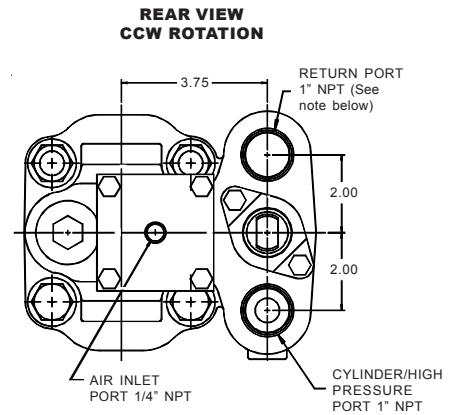
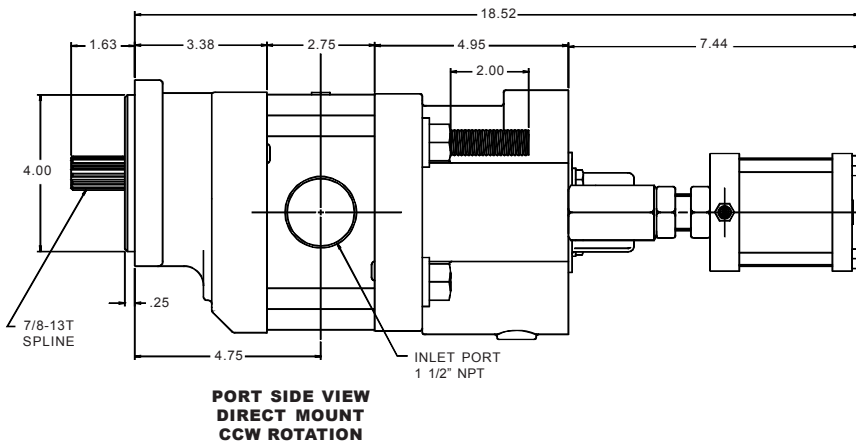

The third line sleeve is installed in the pump, therefore, the return port must be plumbed back to tank, below the oil line at all times.

Pump Code

DG Direct Mount, SAE 4 Bolt "B"	DG - 20 - Z - L - AS - 25/32 - **
RG Remote Mount	
20 2.0" Gear / 37 GPM at 1800 RPM	
Z 3 Line Sleeve Installed	
L Left Hand Rotation	
R Right Hand Rotation	
AS *Air Shift of Main Spool	

**Extended Stud Orientation

Delete	Top Two (Std.)
EB	Bottom Two
EL	Left Side
ER	Right Side
E4	All four

Relief Valve Setting

25	2500 PSI Low Pressure
32	3200 PSI High Pressure

*Because of potential interference with aftermarket air shift cylinders, we recommend the Permco "OEM" version.



www.permco.com

1500 Frost Rd.
P. O. Box 2068
Streetsboro, OH 44241

Phone 330-626-2801
Fax 330-626-2805
e-mail info@permco.com

© Bulletin #02-402G