

PERMCO

M197

197 SERIES MOTORS

MEDIUM/SMALL DISPLACEMENT SLEEVE BUSHING MOTORS



197 SERIES FEATURES

- Heavy duty sleeve bushing design in a medium/small frame size
- Cubic inch displacements from .99 through 3.94
- Working pressure up to 3500 PSI
- Speeds up to 2400 RPM
- Torques up to 1790 in-lbs
- Doweled and high strength cast iron construction
- 100% factory tested
- High strength alloy steel gear and shaft sets
- A wide range of porting, mounting, and shaft options available
- Pressure balanced wear plates maintain high pump efficiency throughout all operating ranges
- Available in both single and tandem units



The Sensible Choice

Dimensional Data (inches)

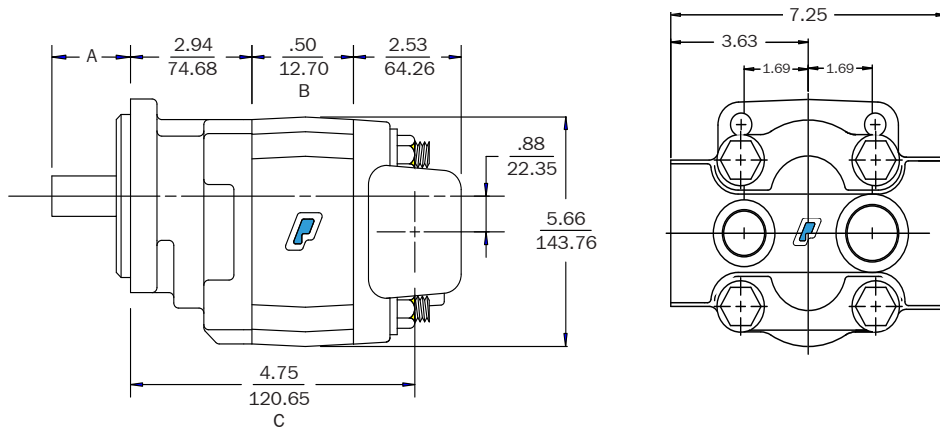

- A. See bushing series catalog for lengths and dimensions
- B. 0.50" plus gear width
- C. 4.75" plus gear width
- D. 9.60" plus total gear width

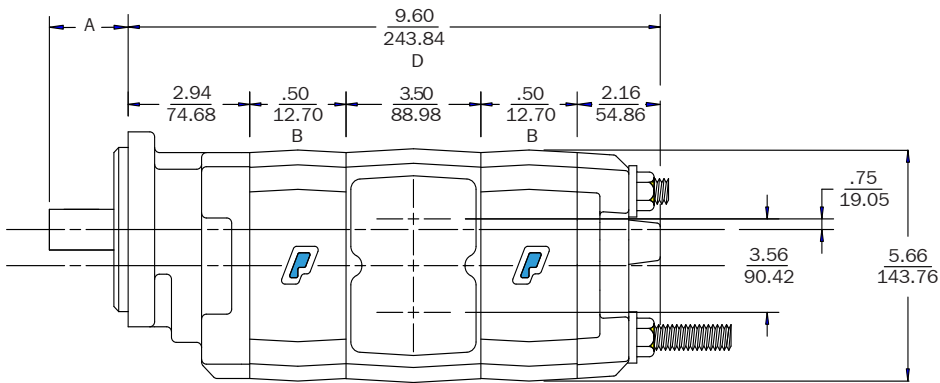

Pump dimensions shown; motor port end cover and bearing carrier dimensions vary slightly; consult factory.

M197 Performance Data @ Rated Pressure

Speed (rpm)	Gear Width									
	1.000"		1.250"		1.500"		1.750"		2.000"	
	Flow (gpm)	Torque (in-lb)	Flow (gpm)	Torque (in-lb)	Flow (gpm)	Torque (in-lb)	Flow (gpm)	Torque (in-lb)	Flow (gpm)	Torque (in-lb)
900	10.1	1051	12.4	1307	14.8	1582	17.1	1708	18.7	1796
1200	12.8	1049	15.8	1306	18.7	1575	21.7	1711	24.0	1793
1500	15.5	1042	19.2	1298	22.7	1571	26.3	1706	29.3	1776
1800	18.2	1037	22.5	1281	26.7	1553	31.0	1694	34.6	1751
2100	20.8	1025	25.9	1270	30.7	1543	35.6	1674	39.9	1727
2400	23.5	1014	29.2	1253	34.8	1527	40.3	1664	45.4	1703
2700	26.2	1010	32.6	1237	38.7	1511	44.9	1646	50.7	1669
3000	28.9	997	36.0	1218	43.0	1501	49.7	1633	56.0	1644

M197 Performance Data @ 2000 PSI

Speed (rpm)	Gear Width									
	1.000"		1.250"		1.500"		1.750"		2.000"	
	Flow (gpm)	Torque (in-lb)	Flow (gpm)	Torque (in-lb)	Flow (gpm)	Torque (in-lb)	Flow (gpm)	Torque (in-lb)	Flow (gpm)	Torque (in-lb)
900	8.7	589	11.3	737	13.5	895	15.5	1042	17.8	1199
1200	11.4	586	14.6	734	17.6	892	20.1	1043	23.2	1187
1500	14.1	584	18.0	729	21.5	880	24.8	1038	28.4	1170
1800	16.9	581	21.3	707	25.4	867	29.5	1029	33.7	1145
2100	19.6	569	24.7	703	29.5	856	34.1	1020	39.1	1130
2400	22.3	557	28.0	681	33.4	843	38.7	1006	44.4	1107
2700	24.9	551	31.3	669	37.5	829	43.4	987	49.8	1076
3000	27.6	538	34.7	652	41.4	813	47.9	974	55.1	1052

Performance data given is based on a series of test with ISO 32 Oil @ 120°F and is not representative of any one unit.

Permco
1500 Frost Rd.
P. O. Box 2068
Streetsboro, OH 44241

Phone 330-626-2801
Fax 330-626-2805
e-mail info@permco.com
www.permco.com

Permco (TianJin) Hydraulics Inc., Ltd.
236 Jinbindadao Free Trade Zone
TianJin Port, China
e-mail technic@permcotj.com
www.permcotj.com

Permco TianJin Fluidpower Mfg.
Fenghua Industrial Park
9th Avenue
TEDA, China 300457